

Amphenol

TB-2052

MALE BLADE CONTACT EXTRACTION TOOL FOR M1000, M1001, M1200, M1201,
M1500, AND M1501 SERIES - PART NO. 600-0001-000

REVISION “-”

SPECIFICATION REVISION STATUS

<u>Revision</u>	<u>SCR No.</u>	<u>Description</u>	<u>Initial</u>	<u>Date</u>
“-”	26412	Initial Release (Supercedes TB-210)	H. Cook	12-18-98

Copyright © 2001 by Amphenol Backplane Systems. The material contained in this document is proprietary to Amphenol Backplane Systems. It may not be disclosed to third parties in any form or by any means, electronic, mechanical, photocopying, or recording without the prior written permission of Amphenol Backplane Systems.

1.0 SCOPE

- 1.1 This technical bulletin covers Male Blade Contact Extraction Tools for M1000, M1001, M1200, M1201, M1500, and M1501 Series, Part No. 600-0001-000.

2.0 PROCEDURE

- 2.1 Intended Use – For extracting damaged contacts from extruded aluminum body connectors (headers).
- 2.2 Method of Use
- 2.2.1 Support connectors with tail of contact facing up. Bend the contact to a straight position. It may be necessary to bend contacts in the second or third rows to make room for extraction tool. The connector should rest on parallel supports approximately 1” high. The face of the supports should be covered with a protective material such as masking tape to prevent damage to the connector. The supports should be positioned to give maximum support to the connectors in the area of the damaged contacts.
- 2.2.2 Slide the tip of the tool over the tail of the damaged contact until the tool rests upon the hub of the insulator.
- 2.2.3 Hold tool so that it is vertical to the connector in all planes.
- 2.2.4 Strike the top of the tool gently with a small mallet so that the contact and insulator is dislodged downwards. If necessary, hit it a second time to completely dislodge.

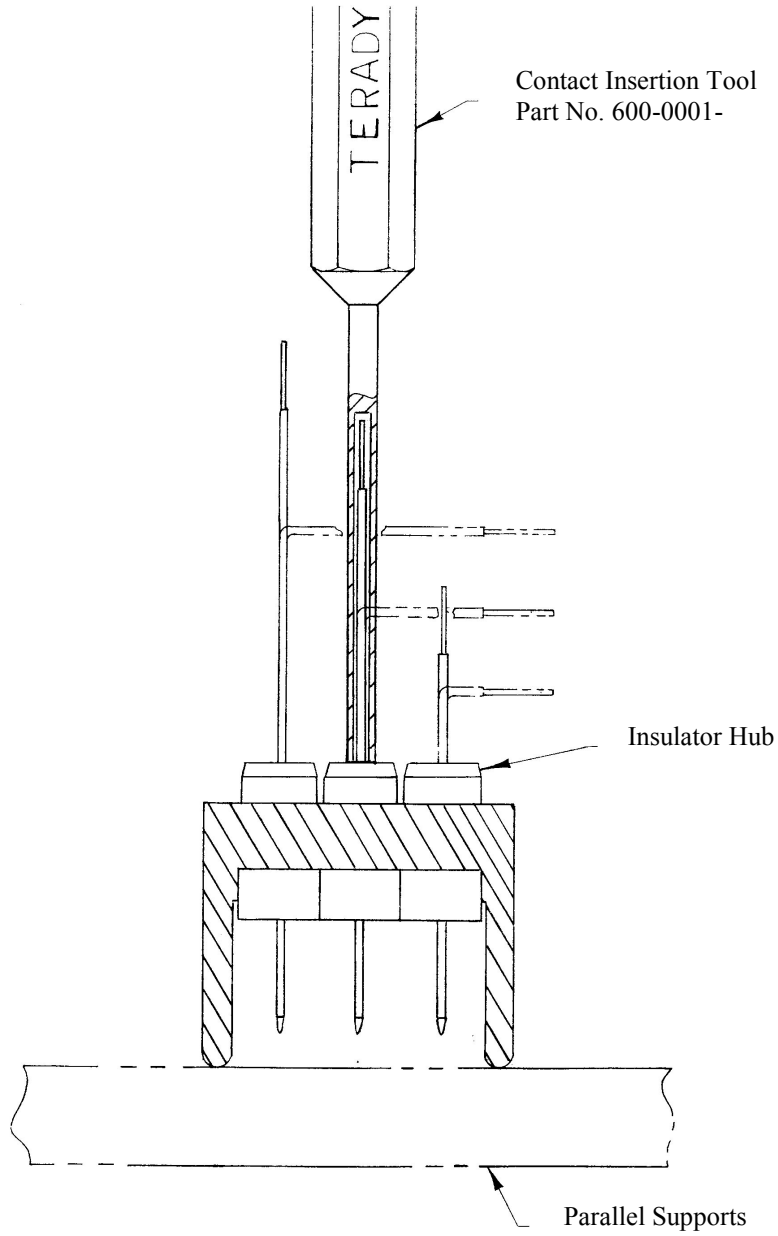

Figure 1