

Product Data Sheet



Amphenol® Ruggedized, Non-Floating Brush Rack and Panel Connector Series

No. 203P

This new connector series utilizes Amphenol's durable and reliable B³ contact system in a rugged, non-floating Rack and Panel connector. Included in this series are digital and power/digital "hybrid" insert arrangements. The hybrid series utilizes Amphenol's high performance RADSOK® power contacts along with Amphenol's proven B³ contact.

The B³ brush (bristle brush bunch) contact is comprised of multiple strands of high tensile wire that intermesh to create an electrical connection.



Benefits of the Brush contact include:

- Redundant current paths: 14-70 gas tight points of contact per mated bunch
- Very smooth low friction interface
- Low mating forces: 1.0 oz. typical
- Long contact life: 100,000+ mating cycles, even when hot swapped

- Documented intermittency free performance: No 10 nano-second discontinuities during 50,000,000 cycles of 0.010 inch "fretting" displacement
- Impervious to fretting
- Contact interface meets M55302/166 thru /171

Connector Features Include:

- 104 High performance B³ contacts
- 0.100" x 0.100" square grid footprint
- Environmentally sealed at connector interface when mated*
- Environmentally sealed connector mounting interface

- EMI protection at mounting surfaces and connector interface*
 - ESD protection – allows use of Class 3 hardened chips* (4KV max. voltage)
- *Indicates optional feature

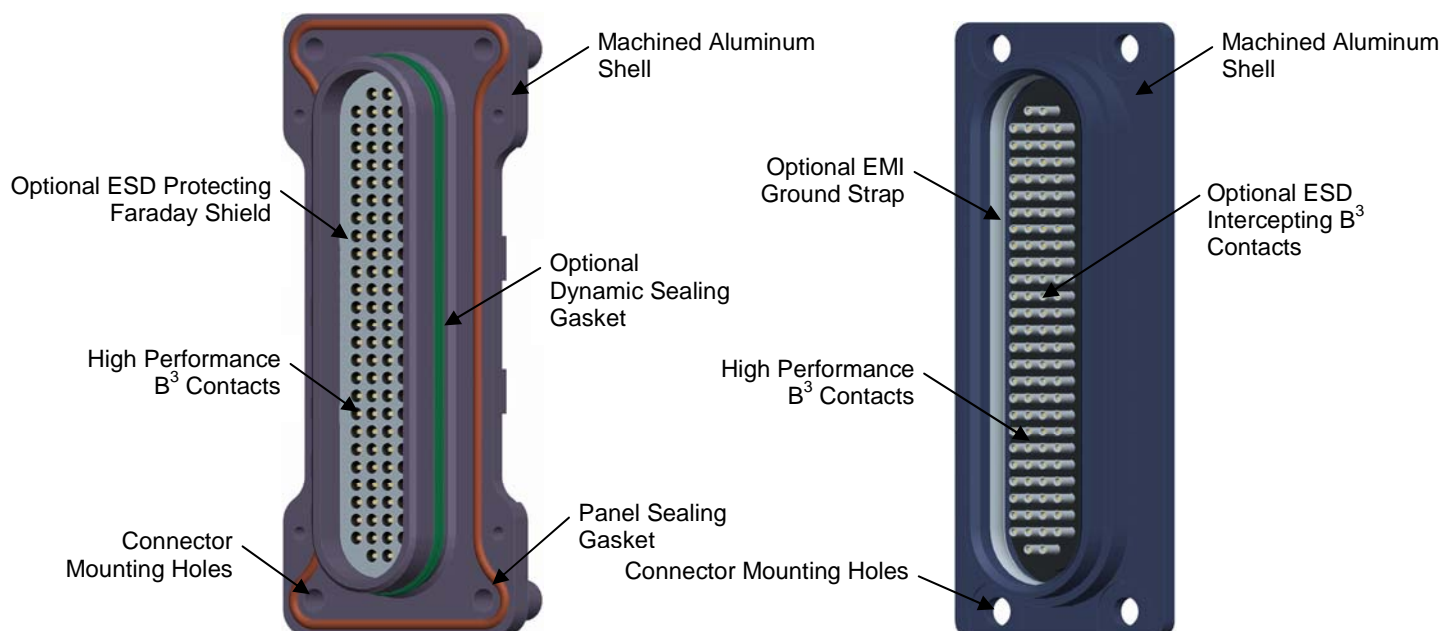

Ruggedized, Non-Floating Brush Rack and Panel Signal Connector

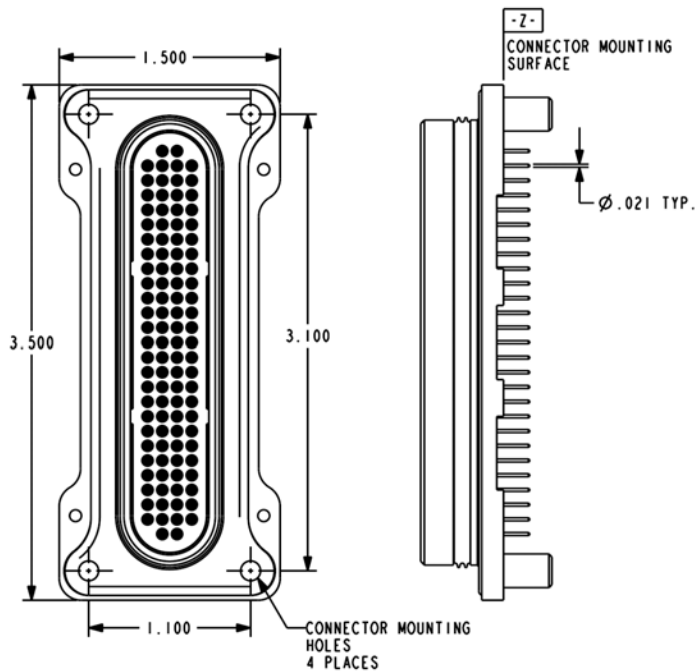

Backplane Connector
(Rear Panel Mount Shown)

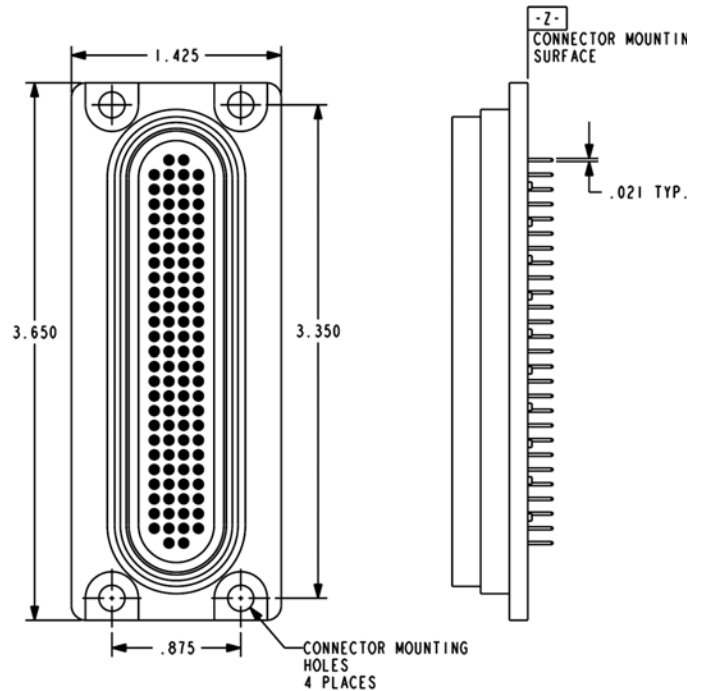

Module Connector
(Front Panel Mount Shown)

How to Order:

Rack & Panel Signal Example Part Number: **R P S - M R 4 - 01 A C D H ****

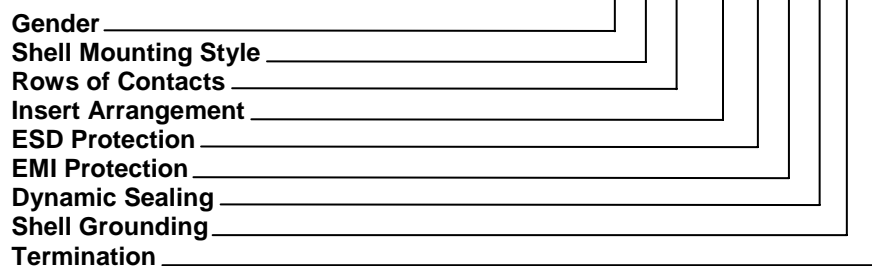

Gender

M – Module Connector
B – Backplane Connector

Shell Mounting Style

F – Front Panel Mount
R – Rear Panel Mount

Rows of Contacts

4 (4 Rows of Contacts)

Insert Arrangement

01 (104 Brush Contacts)

ESD Protection

A – ESD Protection
B – No ESD Protection

EMI Protection¹

C – EMI Protection
D – No EMI Protection

Dynamic Sealing²

E – Dynamic Sealing Gasket
F – No Dynamic Sealing Gasket

Shell Grounding

G – Shell Grounding
H – No Shell Grounding

Termination

** - Contact factory for termination styles and current availability

¹ – EMI Protection option applies to module connector only, EMI ground strap is assembled on module connector assembly. Complete backplane part number with option 'D'.
² – Dynamic Sealing option applies to backplane connector only, Dynamic Sealing Gasket is assembled on backplane connector. Complete module part number with option 'F'.

Ruggedized, Non-Floating Brush Hybrid Rack and Panel Signal Connector

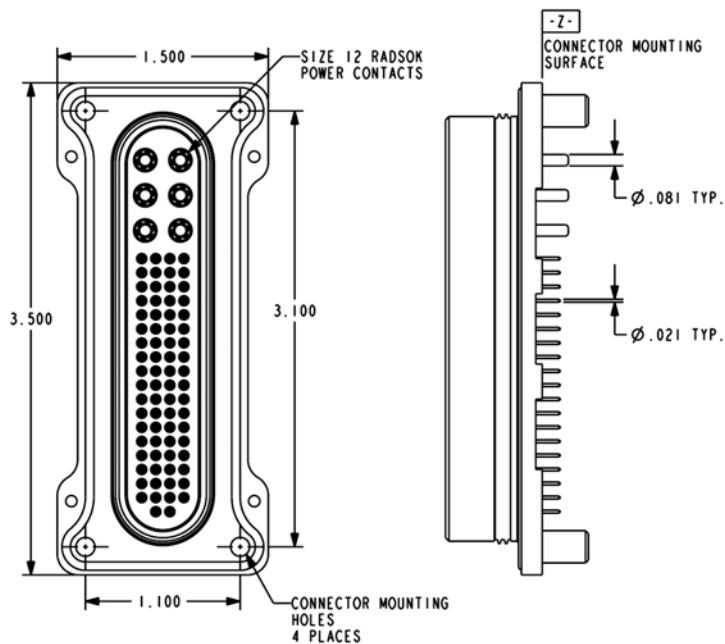

Backplane Connector
(Rear Panel Mount Shown)

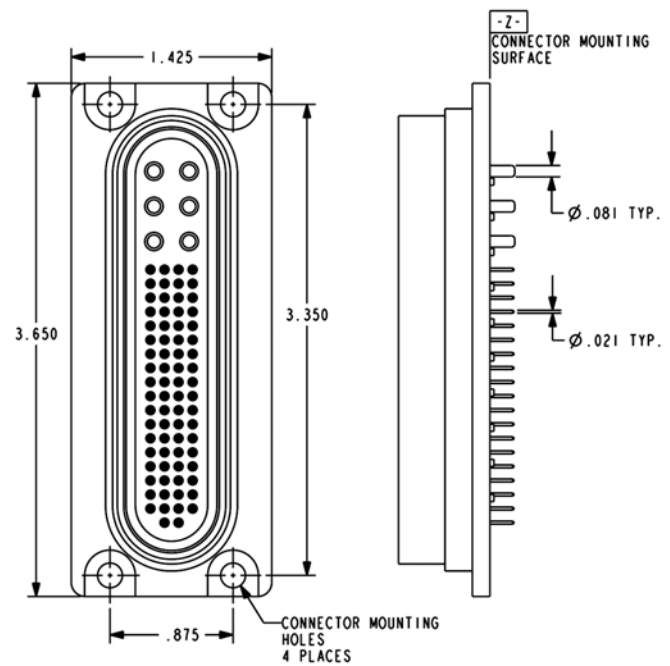

Module Connector
(Front Panel Mount Shown)

How to Order:

Rack & Panel Hybrid Example Part Number: **R P H - M R 4 - 01 A C D H ****

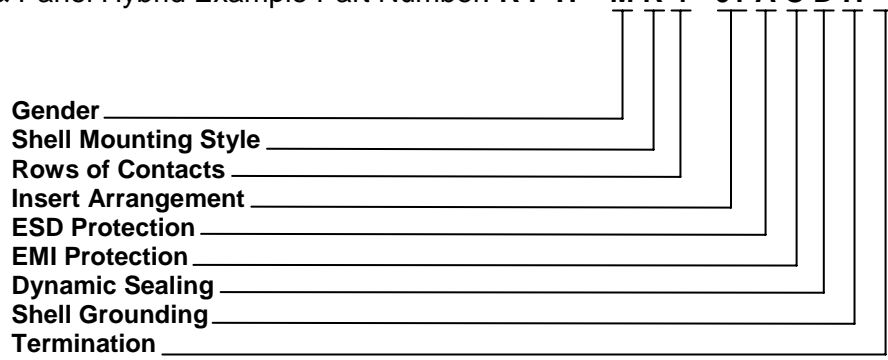

Gender

M – Module Connector
B – Backplane Connector

Shell Mounting Style

F – Front Panel Mount
R – Rear Panel Mount

Rows of Contacts

4 (4 Rows of Contacts)

Insert Arrangement

01 (94 Signal / 02 Power)
03 (74 Signal / 06 Power)
05 (54 Signal / 10 Power)

ESD Protection

A – ESD Protection
B – No ESD Protection

EMI Protection¹

C – EMI Protection
D – No EMI Protection

Dynamic Sealing²

E – Dynamic Sealing Gasket
F – No Dynamic Sealing Gasket

Shell Grounding

G – Shell Grounding
H – No Shell Grounding

Termination

** - Contact factory for termination styles and current availability

¹ – EMI Protection option applies to module connector only, EMI ground strap is assembled on module connector assembly. Complete backplane part number with option 'D'.
² – Dynamic Sealing option applies to backplane connector only, Dynamic Sealing Gasket is assembled on backplane connector. Complete module part number with option 'F'.

Ruggedized, Non-Floating Brush Hybrid Rack and Panel Signal Connector Insert Arrangements

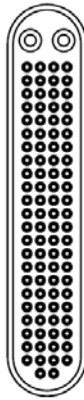

094 SIGNAL / 02 POWER
HYBRID INSERT

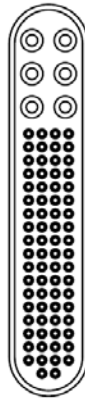

074 SIGNAL / 06 POWER
HYBRID INSERT

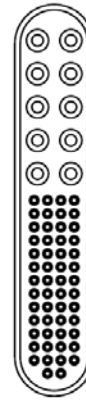

095 SIGNAL / 10 POWER
HYBRID INSERT

Connector Performance: *Standard performance requirements for 104 pin signal version*

Durability:	500 mating cycles
Insertion / Extraction Force:	7 lbs typical
Operating Temperature:	-60° to 125°C
Current Rating:	3 amperes Hot swap 1 ampere maximum (load dependent) – <i>Non ESD protected version only</i>
Insulation Resistance:	1 gigaohm minimum
Dielectric Withstanding Voltage:	500V, 60 Hz RMS @ Sea Level 300V, 60 Hz RMS @ 15,000 ft Elevation
Solderability:	J-STD-004, -005 & -006
Salt Fog:	EIA-364-26B, test condition B
Humidity:	EIA-364-31B, test method III
Vibration:	EIA-364-28B, test condition III
Shock:	EIA-364-27B, test condition G

For additional information on this product or other Amphenol products contact:

Amphenol Corporation

Amphenol Aerospace

40-60 Delaware Avenue

Sidney, New York 13838-1395

Phone: 1 -607-563-5011 or 800-678-0141

Fax: 1-607-563-5351

Web: www.amphenol-aerospace.com

See Amphenol High Performance Line Replaceable Module (LRM) Interconnects Catalog, 12-037.