



Quad-Channel 370 MSPS 16-bit Analog Input A/D Connector

ADC-4CH-370M-16

APPLICATIONS

- + Signal Intelligence (SIGINT)
- + Electronic Counter Measures (ECM)
- + Radar and Smart Antenna Arrays
- + Sensors
- + Munitions Guidance
- + Motor Control Feedback
- + Network and Vector Analyzers
- + Microwave Receivers
- + Software Defined Radios
- + Quadrature and Diversity Radio Receivers
- + Digital Satellite Payloads
- + Data Storage

FEATURES

- + Quad 370 MSPS 16-bit ADCs
- + Onboard programmable sample clock
- + Option for internal or external ADC clock
- + Optional pass through clock for facilitating additions
- + Integrated MIL-DTL-38999
- + Rugged and naturally convection cooled
- + Large range of acceptable supply voltages
- + JESD204B interface

BENEFITS

- + Increase PCB space
- + 16 bit resolution
- + Able to synchronize multiple channels/boards
- + Easily interfaces to FPGA-based host board
- + Removes bulky RF cabling
- + Removes costly development
- + Low power consumption
- + TI development board compatibility

OVERVIEW

The ADC-4CH-370M-16 is a four channel, 370 MSPS, 16-bit analog converter. This utilizes an integrated MIL-DTL-38999. The JESD204B I/O devices are to be directly coupled to a host FPGA. The four channel ADC (x2) devices connect through the high bandwidth connector to a FPGA-based host board which maximizes data throughput and minimizes latency.

The ADC-4CH-370M-16 supports an onboard programmable sample clock generator as well as an external reference input. Multiple ADC-4CH-370M-16 can be synchronized to increase the number of input channels through the use of trigger input/output signals directly under the control of the FPGA.

ANALOG INPUT

The ADC-4CH-370M-16 supports eight inputs through 50Ω MMCX type front panel connectors. The analog inputs are single-ended and are coupled to TI ADC16DX370 ADCs using a balun and AC coupling capacitor configuration to produce the broadband differential input required by the devices.

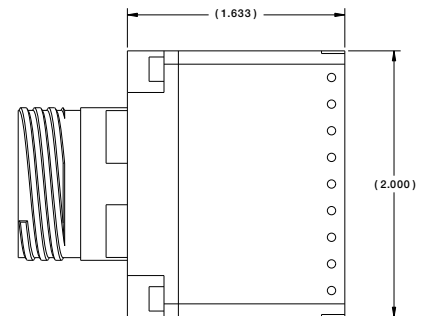
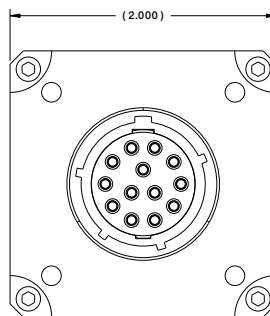

CONTACT US:

Jared Sibrava

E-mail: jsibrava@amphenol-aao.com

Phone: 607-643-1845

Analog Input

NUMBER OF CHANNELS	4 single ended
SAMPLING FREQUENCY	Up to 370 MSPS
DEVICE	TI ADC16DX370
ANALOG BANDWIDTH	UP to 800 MHZ
SFDR (AT 150 MHz)	88 dBFS
SNR (AT 150 MHz)	69.6 dBFS
ENOB (AT 150 MHz)	11.2 bits
INPUT IMPEDANCE	50 Ohm, AC coupled
INPUT CONNECTOR	MIL-DTL-38999

Digital Interface

NUMBER OF DIFFERENTIAL CHANNELS	4
DEVICE CLOCK	Internal or external triggered
SYSTEM REFERENCE CLOCK	Internal or external triggered
JESD204B SYNCH	External triggered

Clock & Trigger

CLOCK INPUT CONNECTOR	MIL-DTL-38999
CLOCK INPUT	50 Ohm, AC coupled LVPECL
INTERNAL CLOCK	Programmable
TRIGGER INPUT/OUTPUT	Single-ended, 50Ohm, Ohm, LVPECL buffered to host FPGA

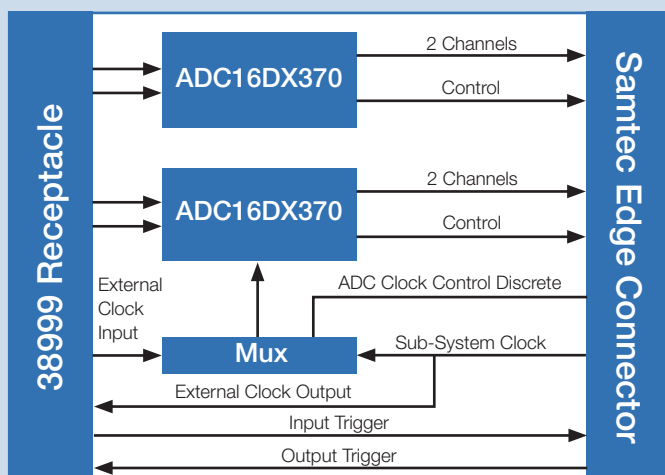

CONTACT US:

Jared Sibrava

E-mail: jsibrava@amphenol-aa.com

Phone: 607-643-1845

DIGITAL OUTPUT

The ADC-4CH-370M-16 features the new JESD204B connecting to Xilinx, Altera, and other host FPGAs. The multiple advantages of this standard interface makes JESD204B the communication of choice by system engineers. The JESD204B allows for reduction of I/O by serializing the data out and incorporating an embedded clock. It also features a deterministic latency feature enabling the ADC to synchronize to the master clock.

CLOCKS, TRIGGERS, & SYNCHRONIZATION

The ADC-4CH-370M-16 sample clock can be driven from either an external source or onboard programmable sample clock generator. The clock source is controlled by the FPGA. The external front panel clock input is provided through contacts on the 38999 connector.

The external sample clock is a 50Ω LVPECL input designed to operate with an input level between 0 dBm and +8 dBm. The clock input may be sinusoidal or square. -Trigger In- and -Trigger Out- are on the 38999 and Samtec interface. The actual functionality of these signals are dependent on the HDL code in the FPGA of the host carrier card.

TI INTEGRATION

Amphenol is pleased to offer complete support with our ADC products with the various development support software and hardware from Texas Instruments. Our components, when accompanied with the correct cables, work seamlessly with the Texas Instruments evaluation setup. Systems integrators can reduce system development time with this approach. No new software or maintenance agreements are needed.

1 -Tone Spectrum, 150 MHz

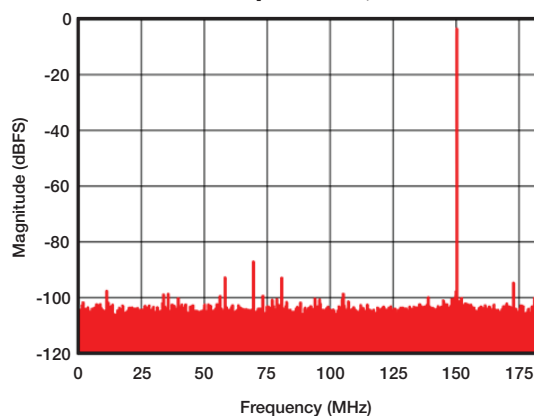

Overview

Amphenol integrated electronic products are designed and manufactured to our Ruggedization guidelines listed below. These guidelines ensure years of reliable operation in harsh environment applications where extreme operating temperatures, shock, vibration and corrosive atmospheres are regularly experienced

Temperature

- Operating Temperature - Thermal Cycles between -40°C and 85°C while device is operating
- Temperature is measured at chassis housing or card edge
- Storage Temperature - Thermal Cycles between -55°C and 125°C

Humidity

- Operating Humidity – Humidity cycle between 0-100% non-condensing humidity while device is operating
- Storage Humidity – Humidity cycle between 0-100% condensing humidity

Sealing

- Sealing can be optionally provided at the MIL-DTL-38999 interface with up to 10-5 cc/sec performance

Fluids Susceptibility

- MIL-DTL-38999 receptacle interface per EIA-364-10E

Vibration & Shock

- Sine Vibration – 10 g Peak, 5-2,000Hz
 - Based on a sine sweep duration of 10 minutes per axis in each of three mutually perpendicular axes. May be displacement limited from 5 to 44 Hz, depending on specific test.
- Random Vibration - 0.005@5Hz, 0.1@15Hz, 0.1@2,000Hz
 - 60 minutes per axis, in each of three mutually perpendicular axes.
- 40 G Peak Shock Cycle
 - Three hits in each axis, both directions, ½ sine and terminal-peak saw tooth, Total 36 hits.

Altitude

- -1,500 to 60,000 ft Altitude Testing w/ Rapid Depressurization

Electromagnetic Compatibility

- Designed to comply with MIL-STD-461E

Printed Circuit Board Assemblies

- Conformal Coat
 - Amphenol performs Conformal Coating to both sides of printed circuit board assemblies using HUMISEAL IB31 in accordance with IPC-610, Class 3.
- Printed Circuit Board Rigidity
 - Amphenol printed circuit boards are fabricated in accordance with IPC-6012, Class 3.
- Printed Circuit Board Fabrication
 - Amphenol printed circuit boards acceptance criteria is in accordance with IPC-610, Class 3.

Reliability Predictions (MTBF)

Amphenol can perform Mean Time Between Failure (MTBF) reliability analysis in full compliance with MIL-HDBK-217F-1 Parts Count Prediction and MIL-HDBK-217F-1 Parts Stress Analysis Prediction. We can also perform reliability analyses in full compliance of ANSI/MTA 51.1 if it is required or preferred over the later method.

CONTACT US:

Jared Sibrava

E-mail: jsibrava@amphenol-aa0.com

Phone: 607-643-1845