

FIELD-PROVEN COTS, MOTS AND CUSTOM MILITARY POWER SOLUTIONS

M255 SERIES

HOLD-UP POWER SUPPLY



PRODUCT HIGHLIGHTS

- POWER LINE CONDITIONER
- DC INPUT RANGE: 18-48V_{DC}
- EMI FILTERS INCLUDED
- OPERATING TEMPERATURE
-55C TO +85C (BASEPLATE)
- DESIGNED TO MEET: MIL-STD-461,
MIL-STD-704, MIL-STD-810, MIL-STD-1275

M255 SERIES HOLD-UP POWER SUPPLY

Applications

Military, Ruggedized, Telecom, Industrial

Special Features

- Miniature size
- High efficiency
- Wide input range
- Fixed switching frequency
- External Synchronization (250 ± 10 kHz)
- EMI filters included
- Indication for Input failure and Hold-Up activation
- External capacitor required.
- Operates together with MPS standard modules. Please consult factory for specific applications.
- More than 990 W·msec per 1 mF capacitance

Environmental Conditions

Meets or exceeds MIL-STD-810C

Temperature:

Operating: -55°C to $+85^{\circ}\text{C}$ (baseplate)

Storage: -55°C to $+125^{\circ}\text{C}$

Vibration level:

Up to 9 grms. For higher vibration levels - please consult factory.

Reliability

150,000 hours, calculated per MIL-STD-217F at $+85^{\circ}\text{C}$ baseplate, Ground Fixed.

Electrical Specifications

DC INPUT

DC Input range: 18 to 48 V_{DC}

Input transient protection:

All models meet or exceed (no damage) MIL-STD-1275A (100 V for 50 ms) and MIL-STD-704A, MIL-STD-704D (80 V for 0.1 Sec)

Steady State input current:

< 50 mA EMC:

Designed to meet* MIL-STD-461C: CE01, CE03, CS06, CS01, RE02, RS02, RS03

Isolation:

200V between Input and Case 200V between Output and Case

DC OUTPUT

Normal input voltage range: According to the external capacitor Output current

capacity:

12 A max.

Consult factory if higher current required.

Isolation:

Output to Case: 200 V_{DC}

M255 SERIES HOLD-UP POWER SUPPLY

Connection Diagram

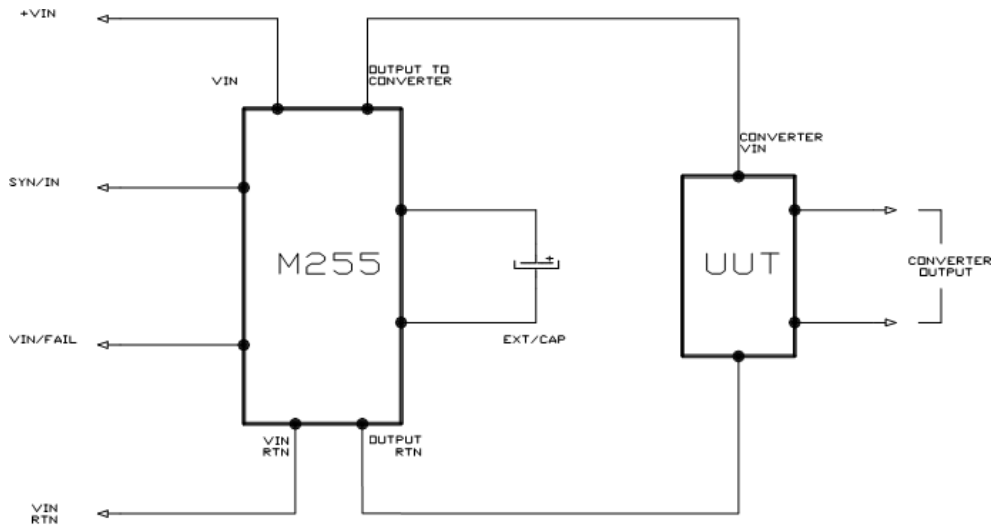

Block Diagram

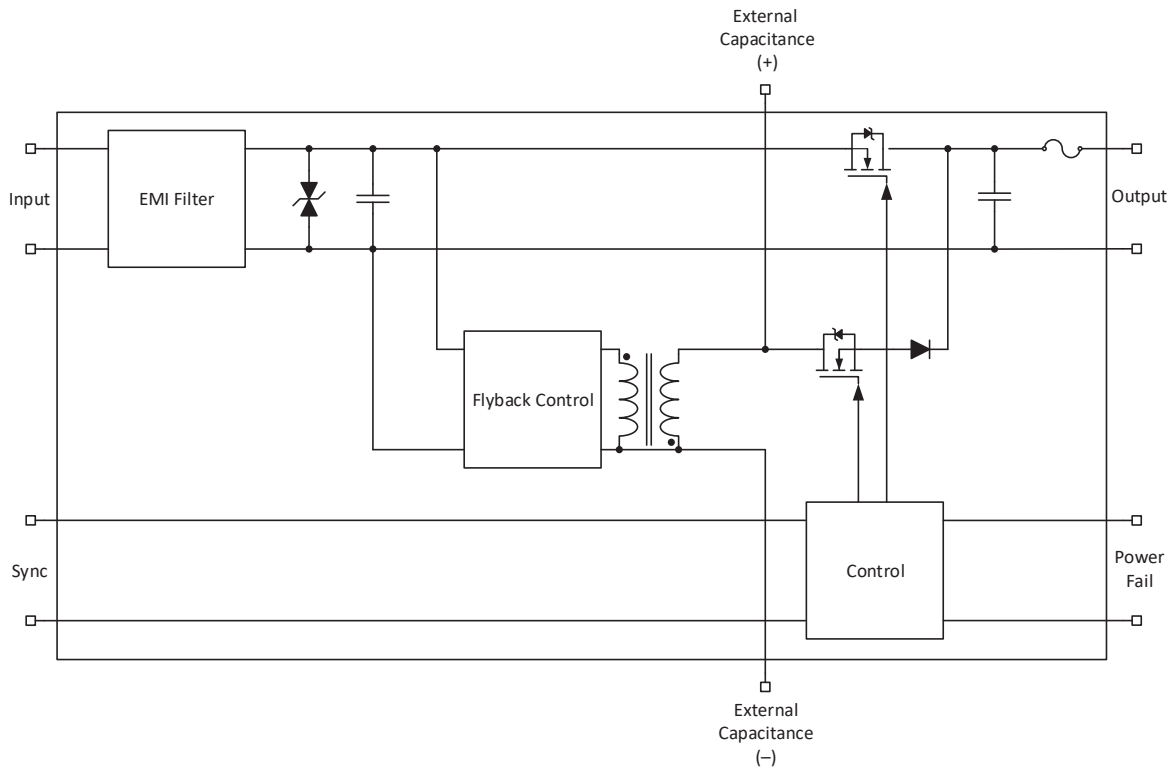

M255 SERIES HOLD-UP POWER SUPPLY

Description of Operation

The holdup unit is meant to be installed in front of a power supply, and not a standalone. It is used for input voltage holding when a power failure occurs, such that if the input power returns to nominal limits in a defined period of time, the load can't tell that a power failure had happened.

This unit is designed to be used with most of Milpower Source's DC/DC converters and DC/AC inverters (consult factory for applicability to specific models).

During normal operation, an internal converter charges the external capacitor to 51 V.

In case a power failure occurs where the input voltage drops below 16 V, the input is disconnected from the output via a MOSFET switch, and the external cap is connected to the output pins through another MOSFET switch. The external cap is then discharged into the cascaded power supply, dropping towards 16V, where the cascaded power supply ceases to operate.

When input power returns (it can happen during cap discharge or after complete loss of power), the MOSFET switches disconnect the output from the external cap, reconnect the input to the output, and the internal converter recharges the external cap back to 51 V, preparing it for the next power failure.

M255 SERIES HOLD-UP POWER SUPPLY

Pin Assignment

Connector type: M55302/61-A30 or eq.

Mates with: M55302/62-A30M or eq.

Pin No.	Pin Function	Polarity
8, 9, 10, 23, 24, 25	VIN	(+)
11, 12, 13, 26, 27	VIN RTN	(-)
16	SYNC	(+)
17	SYNC RTN	(-)
1	VIN FAIL	(+)
2	VIN FAIL RTN	(-)
4, 19	EXTERNAL CAPACITOR	(+)
3, 18	EXTERNAL CAPACITOR RTN	(-)
5, 6, 7, 20, 21, 22	OUTPUT TO CONVERTER	(+)
14, 15, 28, 29, 30	OUTPUT TO CONVERTER RTN	(-)

Outline Drawing

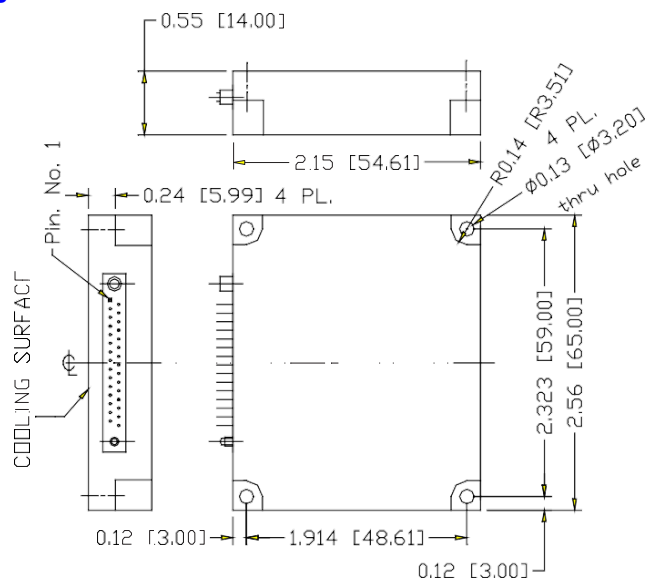

Notes

1. Dimensions are in Inches [mm]
2. Tolerance is:
.XX ±0.01 IN
.XXX ±0.005 IN
3. Weight: Approx. 2.7 Oz (75 gr)

Note: Specifications are subject to change without prior notice by the manufacturer