

M362-4 2.5KW/3KVA UPS for Shipboard Application

(Used with Milpower's M333-4 External Battery Packs)

Milpower Source M362-4 is a rugged, high performance On-Line UPS designed for Naval Shipboard and tough industrial applications. The M362-4 will charge and control up to four external M333-4 Battery Packs connected in a "daisy-chain". *For Ordering Part Number see Page 8.*

The main features of the M362-4 are:

- 19", 3U Rack-mount, 18.25" deep with recessed I/O connectors to fit in shallow racks.
- Full Compliance with MIL-STD-1399 (Section 300B), Type-I Power (115VAC/60Hz, Delta).
- 115/230VAC Input selectable (output, including in By-pass, is always 115VAC).
- Internal Input Isolation Transformer.
- Accepts up to four external Battery Packs (at least one external Battery Pack must be used).
- Long Holdup time: over 2 hours at 1KW and one hour at 2KW (with four M333-4 Battery Packs).
- Real sine-wave 115VAC/60Hz output, synthesized from a crystal oscillator.
- Very low Input Current Harmonic and high Power factor (MIL-STD-1399-300B compliant).
- Inrush Current limiting (MIL-STD-1399-300B compliant).
- Very low input-to-chassis capacitance (MIL-STD-1399-300B and MIL-STD-461E compliant).
- Full galvanic isolation between Input, Chassis GND and Output.
- 1000V / 50µs spike capability (MIL-STD-1399-300B compliant).
- Complies with MIL-STD-461E.
- Complies with MIL-S-901D (Grade A, Class I &2) and MIL-STD-167-1 (Type I).
- Remote Panel ON/OFF capability.
- By-pass mode, via internal Power Conditioner, Isolation Transformer and Relays.
- RS-232 or Ethernet SNMP v1, v2 or v3 Control and Monitor.
- J-STD-001B and IPC-610A Class-3 Workmanship.
- Conformal Coating of PWBs per MIL-I-46058C and IPC-CC-830.

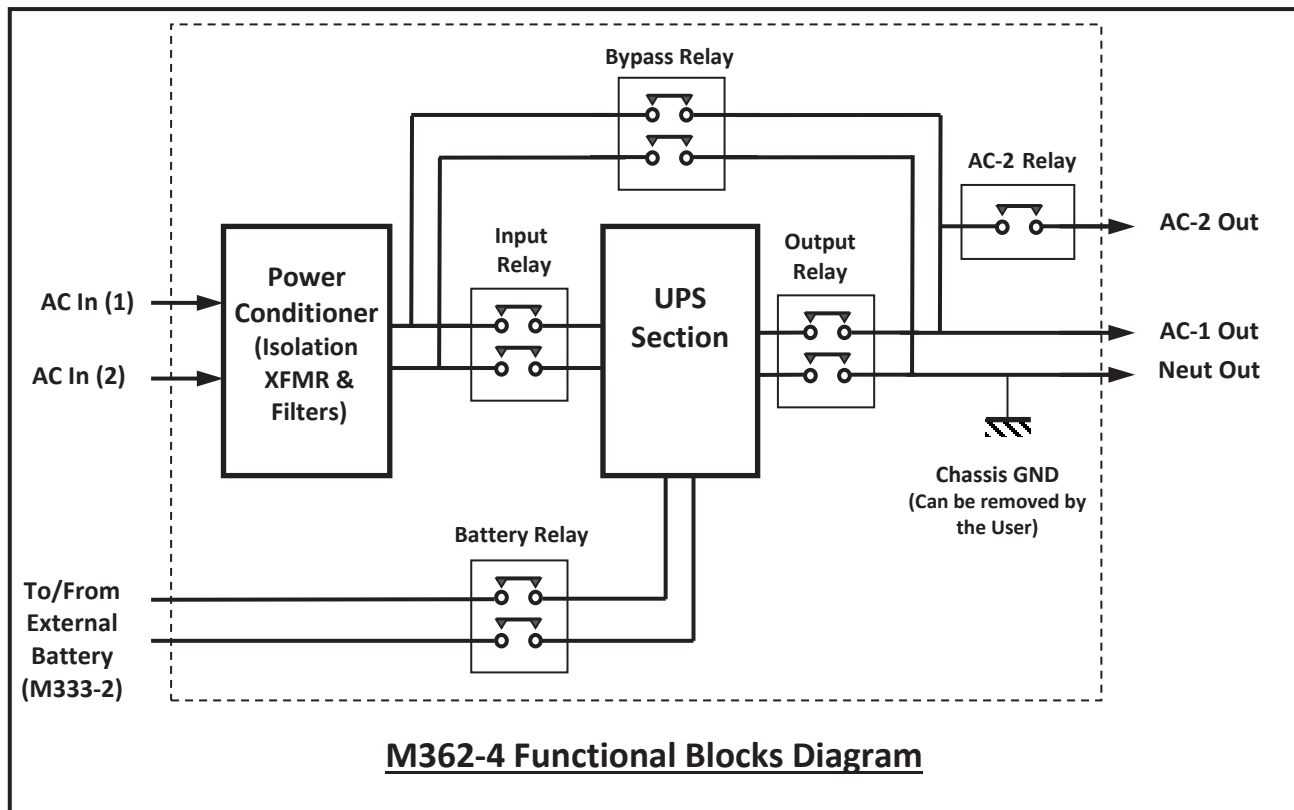

Specification:

AC Input	Voltage Range	115VAC/60Hz ±5%. In accordance with MIL-STD-1399-300B, Type I, Single phase.
	Switchover Voltage	Below 102VAC the M362-4 may switch to Battery power. (MIL-STD-1399-300B worst-case minimum steady state voltage is 107VAC.)
	Frequency	48-64 Hz. Full compliance with MIL-STD-1399-300B.
	Power Factor	> 97% at full rated load.
	Spikes	Withstand 1,000V/50µS Spike I.A.W. MIL-STD-1399-300B.
	Isolation	Input is galvanically isolated from output and chassis (> 10 MOhm at 600VDC). AC Input is isolated from AC Output (including By-pass Mode) by an internal, 130dB Isolation Transformer. Total capacitance between input and chassis is less than 0.02uf per line. Leakage current is less than 2ma. Fully complies with MIL-STD-1399-300B.
	Current waveform	Sinusoidal with harmonic content of less than 2.5% (I.A.W. MIL-STD-1399).
	Input Current Limit	Input Current is actively limited by the UPS to 30Arms (including during Overload).
AC Output	Output Configuration	Two Outputs (AC1 and AC2) sharing a common Neutral. AC-2 is intended for non-essential loads and in case of a prolong failure of the AC Input, the user may save battery power by configuring/commanding (via the RS232) AC-2 to shutdown. (At shipping, the AC-2 turn off delay is set to 12 seconds after AC Input Fail.)
	Transition Time	Zero, no interruption upon transition from AC Input to Battery and backward.
	Voltage	115Vac ±4%.
	Power Rating	2.5KW/3KVA (total for both outputs). AC2 should not be loaded by more than 1.1KVA (10Amp).
	Frequency	60Hz ± 0.2% (digitally synthesized from a crystal oscillator).
	Distortions	Less than 5% (linear load)
	Isolation	Grounded Neutral (by a removable Jumper).When the ground connection Jumper is opened, the AC Outputs are isolated from Input and chassis (>10M Ohm at 500Vdc)

Battery	Type	Uses External Battery Pack Model M333-4. Up to four (4) Packs can be connected in a “daisy-chain” configuration. The M362-4 automatically identifies the Battery’s configuration.
	Holdup Time	See the M333-4 Data-sheet/Users Manual..
	Charger	Low ripple, current limited, fast charger. Can charge up to four M333-4 Battery Packs. Charges a fully depleted M333-4 Battery Pack in less than 8 hours.
	Protections	Over-discharge, Overvoltage and Open Battery protections. Turning off the M362-4, opening the Battery Cable, or pushing on the Safe-to-Remove Push-button, disconnects the Battery (remove power from the Battery’s I/O connectors).
Controls	Front Panel Controls	<p>Power On/Off Switch: When Off; shuts down the M362-4 and opens 2-pole relays that disconnect the AC Input, the AC Output and the Battery Pack.</p> <p>Output On/Off Switch: Opens a 2-pole relay that disconnects the AC Outputs.</p> <p>Input On/Off Switch: Opens a 2-pole relay that disconnects the AC Input.</p> <p>Alarm Off Push Button: Silences the audible alarm.</p> <p>Safe-to-Remove/Batter Test Push Button: When briefly depressed initiates a Battery Connection Test. When depressed for 5 Sec, disconnects the Battery and allows Battery Hot Swapping. (Another brief depress will reconnect the Battery).</p>
	Battle Mode Input	An Opto-isolated input. $I > 2.5\text{mA} @ 3.5\text{Vdc}$ will drive the UPS into Battle Mode (disabling the Overtemp protection). $I < 0.05\text{mA} @ V < 0.5\text{Vdc}$ disables the Battle Mode. $V_{\text{max}} = 11\text{Vdc}$ (unless externally limited to 20mA).
	Remote Switches	<p>The M362-4 can be controlled by two remotely located switches.</p> <p>RMT PWR On/Off Switch: When open; shuts down the M362 and opens 2-pole relays that disconnect the AC Input, the AC Output and the Battery Pack.</p> <p>RMT Bypass/UPS Switch: When open, disconnects the UPS section from AC Input and Outputs and enables the By-Pass relay.</p> <p>The switches (not supplied) should be rated to 0.5Amp/30Vdc.</p>
Output Signals	Discrete Signals	<p>OUTPUT_OK Signal: Low indicates a regulated (“good”) AC Output. High (open) indicates no (or “bad”) AC Output.</p> <p>ON_BATT Signal: Low indicates that the UPS operates on Battery power (AC Input failure). High (open) indicates that the AC Input has recovered.</p> <p>LOW_BATT Signal: Low indicates that the remaining Battery Charge has dropped below 35%. High (open) indicates that the Battery Charge is above 35%.</p> <p>O_TEMP Signal: Low indicates that the UPS temperature has exceeded its allowed maximum and if remains high, the UPS will shut down (goes to By-pass) in three (3) minutes. High (open) indicates no Over Temperature condition.</p> <p>All of the above signals are Opto-isolated, Open-collector, active Low ($V < 0.5\text{V} @ 2\text{mA}$) signals. Non-active is Open/High ($I < 0.1\text{mA} @ 5\text{Vdc}$). $V_{\text{max}} = 15\text{Vdc}$, $I_{\text{max}} = 10\text{mA}$.</p>

	Data & Control	RS-232 Serial port (Standard) or ETHERNET SNMP v1, v2 or v3 (Optional).
--	---------------------------	---

Environment	Temperature	Non operating: -40° to +70°C Operating: -10° to + 55°C
	Thermal Shocks	-10°C to +70°C, Per MIL-STD-202, Method 107, Cond. A, 20°C/min
	Humidity	Up to 95% (Per MIL-STD-810F, Method 507.4)
	Altitude	Operating: Up to 10,000 feet. Non-operating: (Air transport) 50,000 feet.
	Mechanical Shock	MIL-S-901D (Grade A, Class I &2)
	Vibration	Shipboard Vibration Per MIL-STD-167-1 (Type 1)
	Salt Spray/Fog	Per MIL-STD-810F, Method 509.4
	Sand and dust	Per MIL-STD-810F, Method 510.4.
EMI	MIL-STD-461E	CE102, CS101 (Navy Shipboard Limit), CS114 (10KHz to 400MHz, Curve #5), CS115, CS116, RE101, RE102 (Surface- ship and Internal-submarine limits), RS101 (Navy all Applications) and RS103 (2MHz to 18GHz 50V/m).
	DC Magnetic Field	1600Amp/m (20 oersteds) Per MIL-STD-1399 Section 70.
Fungus		Does not nurture fungus growth.
Acoustic Noise		Less than 65dBA at one meter
Size and Weight		See DWG M362004 (19" Rack Mount, 3U High, less than 90 pounds)

Power Connectors Designation and Pin Out

J1 – AC Input MS3452L20-22P or Eq.		
A	GND	AWG #8
B	N/C	AWG#16
C	AC-IN(1)	AWG #8
D	N/C	AWG#16
E	AC-IN(2)	AWG #8
F	N/C	AWG#16

J2 – AC Output MS3452L20-22S or Eq		
A	GND	AWG #8
B	115VAC-2 (NEUT)	AWG#16
C	115VAC-1 (NEUT)	AWG #8
D	GND	AWG#16
E	115VAC-1	AWG #8
F	115VAC-2	AWG#16

J7 – Battery MS3452L20-27S or Eq						
A	GND	AWG #16		H	BATT-RTN	AWG #16
B	IDRES-2	AWG #16		I	BATT-RTN	AWG #16
C	TMPSNS-1	AWG #16		J	RESERVED	AWG #16
D	TMPSNS-2	AWG #16		K	24VDCRTN	AWG #16
E	+BATT	AWG #16		L	IDRES-1	AWG #16
F	+BATT	AWG #16		M	+BATT	AWG #16
G	+24VDC	AWG #16		N	BATT-RTN	AWG #16

Notes:

- 1) The Connectors P/N shown above are of the M362-4's connectors (not the mating connectors).
- 2) The 115VAC-1 (NEUT) and the 115VAC-2 (NEUT) are the Neutrals of the AC outputs. They are tied together and to Chassis GND in the M362-4.
- 3) The GND Lines on J1 and J2 are Safety Ground. In addition to tying these pins to the proper GND at the far side of the cables, the M362-4 GND Point (on the rear panel) must be grounded to the Host Rack using #8 wire (as short as practical) or (preferably) a low-inductance braid rated to 40Amp or higher.
- 4) For proper operation of the Battery Pack, all Pins of J7 must be connected.

Signal Connectors Designation and Pin Out

J3 – Discrete Signals			D-Type 25 Female		
1	BTL_MOD_CMD	AWG#20	14	BTL_MOD_CMD_RTN	AWG#20
2	N.C.	AWG#20	15	N.C.	AWG#20
3	RMT_SW_RTN	AWG#20	16	RMT_SW_RTN	AWG#20
4	RMT_SW_RTN	AWG#20	17	RESERVED	AWG#20
5	RMT_PWR_ON_SW	AWG#20	18	RMT_UPS/BYPASS_SW	AWG#20
6	N.C.	AWG#20	19	N.C.	AWG#20
7	RS232_RTN	AWG#20	20	RS232_TXD	AWG#20
8	RESERVED	AWG#20	21	RS232_RXD	AWG#20
9	RESERVED	AWG#20	22	N.C.	AWG#20
10	N.C.	AWG#20	23	O_TEMP_SIG	AWG#20
11	OUTPUT_OK_SIG	AWG#20	24	SIG_RTN	AWG#20
12	N.C.	AWG#20	25	LOW_BATT_SIG	AWG#20
13	ON_BATT_SIG	AWG#20			

J4 – Remote ON/OFF		
D-Type 15 Female		
1	N/C	AWG #20
2	N/C	AWG #20
3	RMT_SW_RTN	AWG #20
4	RMT_SW_RTN	AWG #20
5	RMT_SW_RTN	AWG #20
6	RMT_UPS/BYPASS_SW	AWG #20
7	RESERVED	AWG #20
8	RMT_PWR_ON_SW	AWG #20
9	N/C	AWG #20
10	N/C	AWG #20
11	N/C	AWG #20
12	N/C	AWG #20
13	N/C	AWG #20
14	N/C	AWG #20
15	N/C	AWG #20
1	N/C	AWG #20

J5 – RS-232		
D-Type 9 Female		
1	N.C.	AWG #20
2	RS232_TXD	AWG #20
3	RS232_RXD	AWG #20
4	N.C.	AWG #20
5	RS232_RTN	AWG #20
6	N/C	AWG #20
7	RESERVED	AWG #20
8	RESERVED	AWG #20
9	N/C	AWG #20

Notes:

- 1) The Connectors' P/N shown above are of the M362-4's connectors (not the mating connectors).
- 2) If Remote Switches are not used, short pins 8 of J4 to pin 5 of J4 to, and pins 6 of J4 to pin 4 of J4.
- 3) When interfacing with J5 use 9-pins "straight" RS232 cable.
- 4) Signals of the same name that appear in several connectors are the same signal, provided in more than one connector in order to facilitate convenient cabling. Do not use more than one instance of each signal.

How to Order

Order PN: **M362-4 - 0 - 0 - 0 - 0**

Basic Part Number

Special Options

-0 None (Std.)

Communication Port

-0 RS-232 (Std.)

-1 Ethernet SNMP (v1, v2 or v3),
instead of RS-232 (Consult
Milpower Source Sale)

Optional Special Hardware

-0 None (Std.)

Optional Slides & Load Bearing Pins

-0 None (Std.)

-1 Pins and Slides:
Pins: Jonathan P/N 1005-406 or equivalent
(mate with the UPS back panel's bushings)
Slides: Actron P/N A5520-21 (or eq.)

-2 Pins only (same as -1).