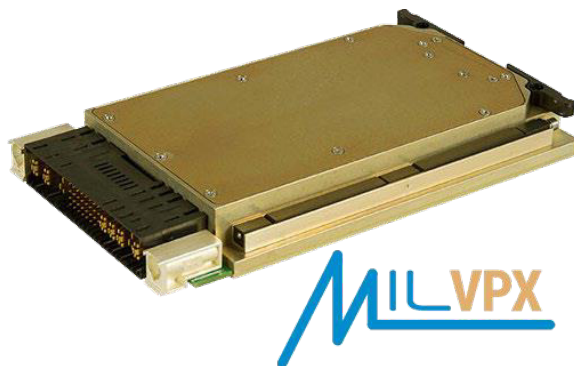


## M4365 SERIES

*DC/DC POWER SUPPLY*



### PRODUCT HIGHLIGHTS

- VITA 62 COMPLIANT
- 3U VPX FORM FACTOR
- DC/DC CONVERTER
- 6 OUTPUTS
- 600W (700W PEAK)
- Current Share for VS# Outputs
- Input Options:
  - MIL-STD-704
  - MIL-STD-1275
- System Management Protocol - VITA 46.11
- Cyber secure

### **Electrical Specifications**

#### **DC Input**

18 to 48 V<sub>DC</sub>

Max Non-Operating 100V

Options:

- 1) MIL-STD-704 (A-F)  
Normal and Abnormal  
Steady State
- 2) MIL-STD-704(A-F)  
transients Up to 50V, 80V
- 3) MIL-STD-1275 Surge
- 4) Def Stan 61-5 170V Load  
dump.

#### **DC Output**

VS1: 12V up to 30A

VS2: 3.3V up to 20A

VS3: 5V up to 30A

12V\_Aux: 12V up to 1A

-12V\_Aux: -12V up to 1A

3.3V\_Aux: 3.3V up to 5A

Peak power option:

VS1: 12V up to 40A

VS3: 5V up to 35A

#### **Isolation**

Over 20 MΩ at test voltage:

200V between Input and Output

200V between Input and Case

100V between Output and Case

#### **Line/Load regulation**

See Table 2 on page 7

#### **Efficiency**

Up to 88%

85.5 % @ Full Load

(See Para. 4)

#### **EMC**

Complies with MIL-STD-461F

(5μH LISN): CE101, CE102,

CS101, CS114, CS115, CS116

#### **Ripple and Noise**

Typically, less than 50mV<sub>p-p</sub>

(max.1%<sub>p</sub>). Measured across a 0.1μF

capacitor and 10μF capacitor on load

at Input Voltage of 18V-36V, all

Temperature Range.

#### **Load Transient Overshoot and Undershoot**

Output dynamic response of less  
than 5% at load Step of 30%-60%.

Output returns to regulation in less  
than 1mSec

#### **System Management**

VITA 46.11 Tier 2 IPMC

Data Available:

- Output voltages and currents
- Input voltage
- Card Temperature
- Card Status

## M4365 SERIES VPX DC/DC POWER SUPPLY

### **Environmental** <sup>1</sup>

Design to Meet MIL-STD-810G

#### **Temperature**

Operating: -55 °C to +85 °C at unit edge  
Storage: -55 °C to +125 °C  
Designed to meet 600 thermal cycles durability test

#### **Fungus**

Does not support fungus growth, in accordance with the guidelines of MIL-STD-454, Requirement 4.

#### **Vibration**

Vibration: Figure 514.6E-1. General minimum integrity exposure. (1 hour per axis.)

**Reliability: 305,000 Hours, calculated IAW MIL-HDBK-217F Notice 2 at +65°C, GF.**

Note 1: **Environmental Stress Screening (ESS)** Including random vibration and thermal cycles is also available. **Please consult factory for details.**

#### **Altitude**

Method 500.5, Procedure I & II  
Storage/Air Transport: 40 kft  
Operation/Air carriage: 70 kft

#### **Salt Fog:**

Method 509.5

#### **Humidity**

Method 507.5, Up to 95% RH

#### **Shock**

Method 516.6  
40g, 11msec saw-tooth  
(all directions)

### **Protections** <sup>‡</sup>

#### **Input**

##### **Input Reverse Polarity:**

Protection for unlimited time

##### **Inrush Current Limiter**

Peak value of  $5 \times I_{IN}$  for initial inrush currents lasting more than 50  $\mu$ Sec.

##### **Under Voltage**

Unit shuts down when input voltage drops below  $17 \pm 0.5$ VDC.  
Automatic restart when input voltage returns to nominal range.

##### **Over Voltage Lock-Out**

Unit shuts down when input steady state voltage rise above  $55 \pm 2$ VDC. Automatic restart when input voltage returns to nominal range.

#### **Output**

##### **Passive over voltage protection on Aux outputs**

Zener selected at  $25\% \pm 5\%$  above nominal voltage, is placed across the output for passive voltage limit.

##### **Active over voltage protection on VS# outputs**

$20\% \pm 5\%$  above nominal voltage.  
Automatic recovery when output voltage drops below threshold.

##### **Overload / Short-Circuit Protection**

Continuous Hiccup protection (110-130%) for VS#.  
Aux Typical:  
3.3Vaux / 8A  
12Vaux. 1.5A-2A  
-12Vaux. 2.5A-3A

#### **General**

##### **Over Temperature Protection**

Automatic shutdown at temperature of  $95 \pm 5$  °C (at unit edge)  
Automatic recovery when temperature drops below  $90 \pm 5$  °C.

**Note 1: Thresholds and protections can be modified / removed (please consult factory)**

### Functions and Signals - According to VITA 62

Signal Name	Type	Description
FAIL*	Output	Indicates to other modules in the system that a failure has occurred in one of the outputs. Please refer to Figure 2 <sup>1</sup>
SYSRESET*	Output	Indicates to other modules in the system that all outputs are within their working level. Please refer to Figure 2 <sup>1</sup>
INHIBIT*	Input	Controls power supply outputs. This signal in conjunction with <b>ENABLE</b> controls the outputs. Please refer to Table 1 and Figure 1 <sup>1</sup>
ENABLE*	Input	Controls power supply outputs. This signal in conjunction with <b>INHIBIT</b> controls the outputs. Please refer to Table 1 and Figure 1 <sup>1</sup>
GA0*, GA1*, GA2*	Input	Used for geographical addressing. GA2 is the most significant bit and GA0 is the least significant bit. <sup>1</sup>
SCL, SDA	Bidirectional	I2C bus Clock and Data respectively. Through this bus the voltage and temperature readouts can be shared. <sup>1</sup>
REF_CLK	Input	The REF_CLK signal is used to allow the power supply frequency to sync with the system frequency. <sup>1</sup>
VOUT SENSE	Input	The SENSE is used to achieve accurate load regulations at load terminals (this is done by connecting the pins directly to the load's terminals).
Alert Bit	Output	Indicates to other modules in the system about Input Voltage loss. Please refer to Figure 2 <sup>1</sup>
Active Current Share	Bidirectional	Support Active current share between Outputs. See Current Share para. <sup>1 2 3</sup>
PO#_SHARE	Bidirectional	Support Passive current share between Outputs <sup>1</sup>

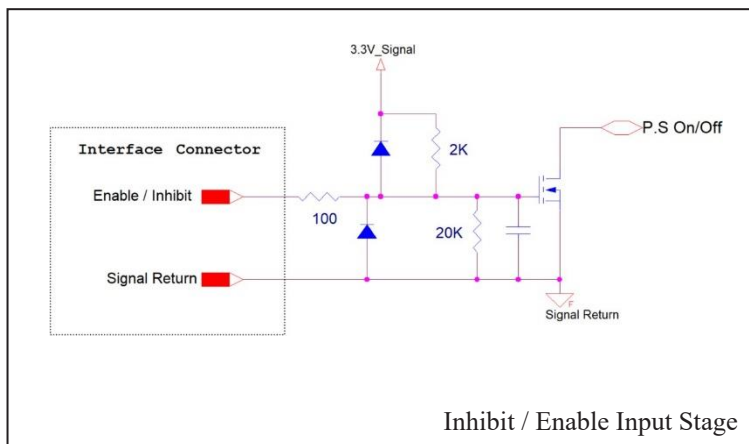
Notes:

1. Signal referenced to **SIGNAL RTN**
2. When not used leave open
3. For Passive or Non-Current Share configuration, this pin is intentionally Disconnected

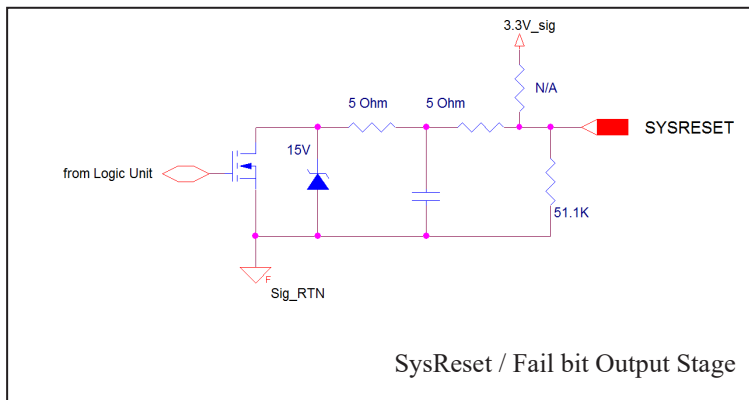
**Table 1 – Inhibit and Enable Functionality**

<b>INHIBIT*</b>	<b>Low</b>	<b>Low</b>	<b>High</b>	<b>High</b>
<b>ENABLE*</b>	<b>Low</b>	<b>High</b>	<b>Low</b>	<b>High</b>
<b>VS1 ,VS2,VS3, ±12VAux</b>	OFF	OFF	ON	OFF
<b>3.3V_AUX</b>	ON	OFF	ON	OFF

**Figure 1 – Inhibit and Enable Input stage**

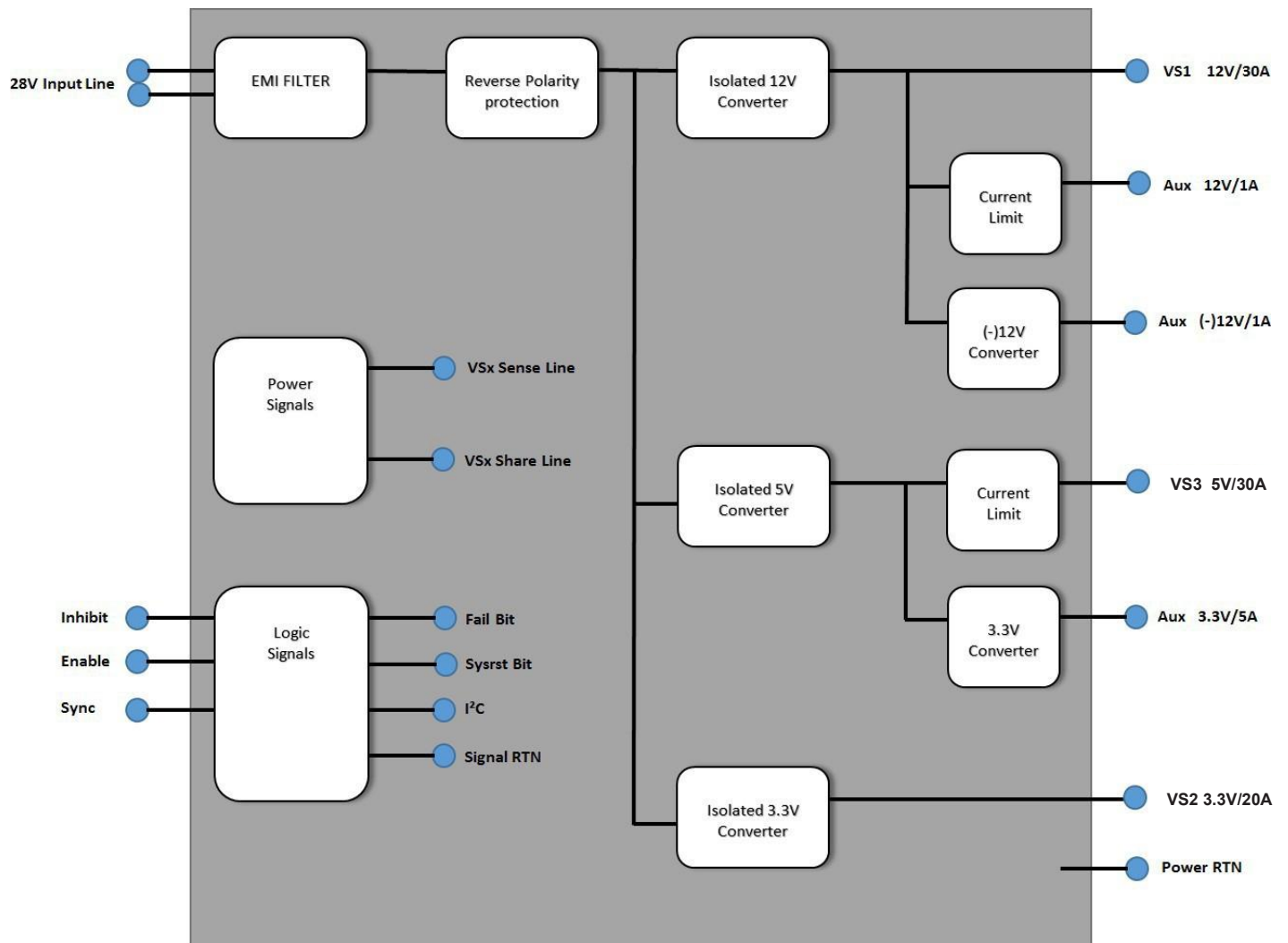


**Figure 2 – SysReset and Fail Bit output stage**



## M4365 SERIES VPX DC/DC POWER SUPPLY

*Simplified Block Diagram*



### Detailed Information

#### 1. M4365 Input Voltage Operation Range.

The M4365 steady state operation voltage is 18V to 48V, continuously work up to 50V Input line. Unit can be modified to work up to 100V or down to 16V transient and Surge.

Max Non operation Voltage 100V.

##### 1.1 Low Line Turn-on and Turn-off Limits

To avoid Turn-on and Turn-off cycling glitch the unit have about 2V Hysteresis.

The Turn-on threshold is under 20V and turn- off below 18V.

Those limits can be adjusted, contact Factory for more information.

#### 2. Outputs Voltage Regulation

The M4365 contains accurate internal sense lines to keep output voltage at less than 3% regulation for all Line/ Load and temperature range (see Table 2).

Output	12V/25A	5V/30A	3.3V/20A	3.3VAux/5A	12VAux/1A	(-)12VAux/1A	Notes
Voltage Range	11.85 – 12.15	4.9 – 5.1	3.28 – 3.42	3.25 – 3.45	11.7 – 12.2	(-)11.85 – (-)12.15	
Voltage Range	11.80 – 12.20	4.9 – 5.2	3.20 – 3.40	3.25 – 3.45	11.7 – 12.2	(-)11.7 – (-)12.2	Current share configuration

Table 2: Outputs voltage regulation. VIN 18V – 48V, Temperature -55 °C – 85 °C single and parallel configuration.

##### 2.1. Sense Lines

*Sense Lines* are provided for VS1, VS2 and VS3 output to compensate line voltage drop.

*Sense Lines* proper connection is shown in Figure 3.

Each VSx output has its own *Sense Lines*, additional common *Sense RTN Line* is provided for all VSx Outputs (VITA 62 Standard).

Contact Factory for Sense configuration different than the VITA 62 standard

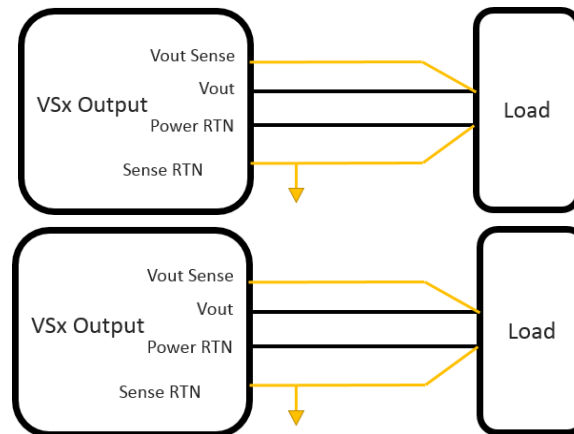


Figure 3: M4365 Sense line connection

## M4365 SERIES VPX DC/DC POWER SUPPLY

### 3. Output Power

The M4365 can deliver up to 616W steady State at all temperature and input range. Unit can support a peak power of 700W, please contact factory for more details and limitations.

Max Total Power Output	12V/30A	5V/30A	3.3V/20A	3.3VAux/5A	12VAux/1A	(-)12VAux/1A
616W	30A	30A	20A	5A	1A	1A
700W	40A	35A	20A	5A	1A	1A

#### 3.1. Mil-STD 1275E Surges (optional)

The Unit can support up to 500W during 12V surge. Operating the unit at higher power may result in a poor output transient response during the surge.

Total Power Output	12V/25A <sup>1</sup>	5V/30A	3.3V/20A	3.3VAux/5A	12VAux/1A	(-)12VAux/1A
500W	22A	30A	20A	5A	1A	1A

**Table 4: Max current per output during 12V surge**

Note 1: Max total current of 12V rail (12Vvs1, 12VAux & (-) 12VAux) should not exceed 22A in order to stay in spec regulation

#### 3.2 Typical Efficiency (Typical results at room temperature)

Input Voltage	Output Power	Efficiency
28V	170W	88%
	200W	87.6%
	600W	86.1%



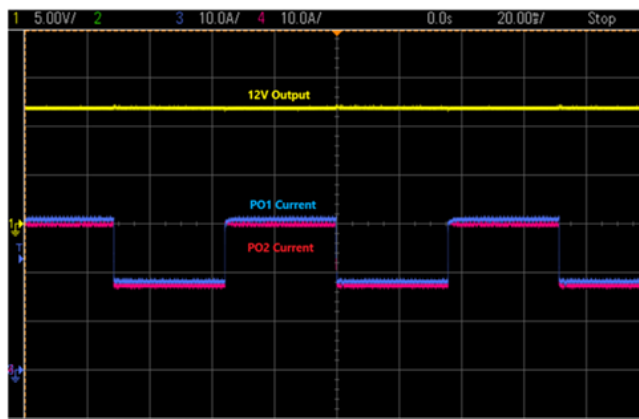
### 4. Current Share (optional)

Current Share FOR vs# Outputs between two or more units is optional (Contact Factory)

#### 4.1 Active current sharing (A.C.S)

Current sharing done in a closed loop. All paralleled outputs are compared and feedback is used to balance their load current. The result is a more stable, less sensitive output voltage without voltage drop. Typical Load Balance of about 2-3A for all Load range is expected.

Typical ACS Dynamic Load of Two 12V Paralleled Outputs (PO1 & PO2 refer to two different units)



Notes 1. When Not used, A.C.S pins can be left open.

#### 4.2 Passive current sharing (P.C.S)

Current sharing is done in open loop, output voltage drops as a function of output load. Load Balance of about 5-10% is expected.

For a required output to current share please connect the following Pins between the two units

- *PO#\_Sense & PO#\_Sense\_RTN*  
(for best performance, Pins from paralleled units should be connected to a single point and as close as possible to the load point)
- Unit 1 *VS#\_SHARE* to Unit 2 *VS#\_SHARE*  
A7 to A7  
B7 to B7  
C7 to C7
- Unit 1 *VS#\_AC SHARE* to Unit 2 *VS#\_AC SHARE* (not required for P.C.S)  
A1 to A1  
B1 to B1  
D1 to D1

### 5. Typical EMI Tests

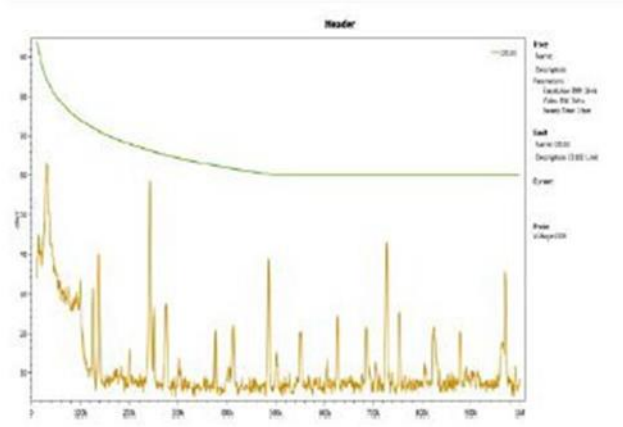
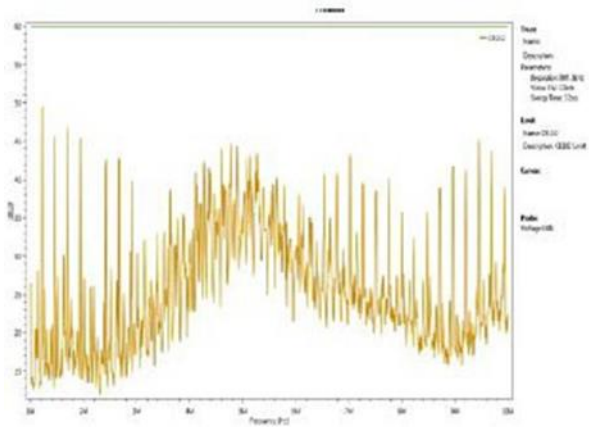


Figure 4: 28V Line, Full Load, 5UH LISN

## M4365 SERIES VPX DC/DC POWER SUPPLY

### 6. Communication Protocol

Unit communication protocol can be configured as **Vita 46.11 Tier 2 IPMC** or **Custom IPMI** compatible protocol. For more details on protocols refer to para. 6.1 and 6.2

#### 6.1. IPMI Protocol

##### Electrical Parameters

Vcc: 3.3VDC  
 Pull-up: 10K Ohm  
 Input Capacitance 330Pf

##### Slave Device Addressing

- 256 address spaces
- Baud rate: 200kHz maximum
- 7 Bit Protocol
- Support Slot Addressing per VITA 62
- Support Global Address 10100101 R/W

Slot Number	MSB							LSB
	A6	A5	A4	A3	A2	A1/*GA1	A0/*GA0	R/W
Slot0	0	1	0	0	0	0	0	
Slot1	0	1	0	0	0	0	1	
Slot2	0	1	0	0	0	1	0	
Slot3	0	1	0	0	0	1	1	
Global Address	1	0	1	0	1	0	1	

\* Slot location is determined by GAx per VITA 62.

##### Communications Supported

Read Command – 21Hex, deliver 64Bytes of Data. (More commands are available by request)  
 The communication starts when the master sends a start followed by the unit slave address, command, checksum and a stop. A second start followed by the slave address and a read will be followed by a 64 Bytes response.

S	Slave Address	R/W	A	Command	A	Check sum	A	P
	A6:A0	0	0	21 Hex	0	DF Hex	0	

S	Slave Address	R/W	A	DATA	A	DATA	A	DATA	A	...	DATA	A	Check sum	N/A	P
	A6:A0	1	0	D7:D0	0	D7:D0	0	D7:D0	0		D7:D0	0	D7:D0	1	

Command – 21Hex read all 64 Bytes

S – Start

P – Stop

Master Transmit	Unit Transmit

## M4365 SERIES VPX DC/DC POWER SUPPLY

### Memory Space

Response Byte #	Data Type	Meaning	Interpretation	Reading Range
0	U Integer, MSB First	Echo of Command		21 Hex
1		Reserved		00 Hex
2	S Integer, MSB First	Temperature -55C to 120C	T(C°)=+/- 7bit Dec	-55 C° to 125 C°
3		Reserved		00 Hex
4-5	U Integer, MSB First	12V VS1 Voltage	V(out) = Data · m2	16.38V
6-7	U Integer, MSB First	3.3V VS2 Voltage	V(out) = Data · m2	16.38V
8-9	U Integer, MSB First	5V VS3 Voltage	V(out) = Data · m2	16.38V
10-11	U Integer, MSB First	3.3V Aux Voltage	V(out) = Data · m2	16.38V
12-13	U Integer, MSB First	12V Aux Voltage	V(out) = Data · m2	16.38V
14-15	U Integer, MSB First	(-)12V  Aux Voltage	V(out) = Data · m2	16.38V
16-17	U Integer, MSB First	12V VS1 Current	V(out) = Data · m3	37.03A*
18-19	U Integer, MSB First	3.3V VS2 Current	V(out) = Data · m3	37.03A*
20-21	U Integer, MSB First	5V VS2 Current	V(out) = Data · m3	37.03A*
22-23	U Integer, MSB First	3.3V Aux Current	V(out) = Data · m4	20.44A
24-35	U Integer, MSB First	12V Aux Current	V(out) = Data · m5	10.22A
26-27	U Integer, MSB First	(-)12V Aux Current	V(out) = Data · m6	4A
28-29	U Integer, MSB First	Reserved		00Hex
30-31	U Integer, MSB First	Reserved		00Hex
32-51	Character String (ASCII)	Part Number	M4265-X (Note1)	20 Characters
52-53	Decimal, MSB First	Serial Number, 2MSB Dig	X,X Dec (Note2)	8 digits
54-55	Decimal, MSB First	Serial Number, 2LSB Dig	X,X Dec (Note2)	
56-57	Decimal, MSB First	Date Code	Week, Year (Note3)	4 digits
58-59	Character String (ASCII)	Hardware Rev	B01 & B02 Boards (Note4)	2 Characters
60-61	Decimal, MSB First	Firmware Rev	X,X,X,X Dec (Note5)	4 digits
62	U Integer, MSB First	Reserved		AA Hex
63	U Integer, MSB First	Zero Checksum	Value required to make the sum of bytes 0 to 62 added to a multiple of 256	

#### Note:

$$M2 = 16.38/2^{16}-1$$

$$M3 = 37.03/2^{16}-1$$

$$M4 = 20.44/2^{16}-1$$

$$M5 = 10.22/2^{16}-1$$

$$M6 = 4/2^{16}-1$$

$$M7 = 80/2^{16}-1$$

\* For unit configuration with paralleled outputs within a single M4265, reading range is 80A. Translation is V(out) = Data·M7.

### Notes 1 to 5

1. Part Number Example: M4065-4

Byte No'	32	33	34	35	36	37	38	39 – 51
Character	M	4	0	6	5	(-)	4	0
Hex	4D	34	30	36	35	2D	34	00

2. Serial Number Example: 25 - Optional

Byte No'	52		53		54		55	
Dec Number	0	0	0	0	0	0	2	5
Binary	"0000"	"0000"	"0000"	"0000"	"0000"	"0000"	"0010"	"0101"

3. Date Code Example: week 35 of 2018 - Optional

Byte No'	56		57	
Dec Number	3	5	1	8
Binary	"0011"	"0101"	"0001"	"1000"

4. Hardware Rev Example: B01 Rev (-), B01 Rev A - Optional

Byte No'	58	59
Character	(-)	A
Hex	2D	41

5. Firmware Rev Example: 2.1.0.0 - Optional

Byte No'	60		61	
Dec Number	2	1	0	0
Binary	"0010"	"0001"	"0000"	"0000"

## 6.2 46.11 Tier 2

Please see *46.11 User Manual* for detailed information of operation.

Sensors included are seen in the table below.

Units are designed to be upgradable to 46.11 Tier 3 compliance upon release of that specification

Record ID	Sensor ID	Sensor Type	Name
0000	00	F0h	FRU State Sensor
0001	01	F1h	System IPMB Link Sensor
0002	02	F2h	FRU Health Sensor
0003	03	02h	FRU Voltage Sensor
0004	04	F3h	FRU Temperature Sensor
0005	05	F4h	Payload Test Results Sensor
0006	06	F5h	Payload Test Status Sensor
0100	07	02h	VS1 Voltage
0101	08	02h	VS2 Voltage
0106	0D	03h	VS1 Current
0107	0E	03h	VS2 Current
010C	13	01h	Analog Temperature
9090	N/A	N/A	Device Locator Record
9999	N/A	N/A	Device Management

## 7. Sync In and Switching Frequency

The unit free running switching frequency while is 220KHz±5%

Unit can be synchronized to External clock signal in frequency range of 200KHz to 300KHz

External clock should be 3.3V CMOS standard logic level with duty cycle between 20% to 80%.

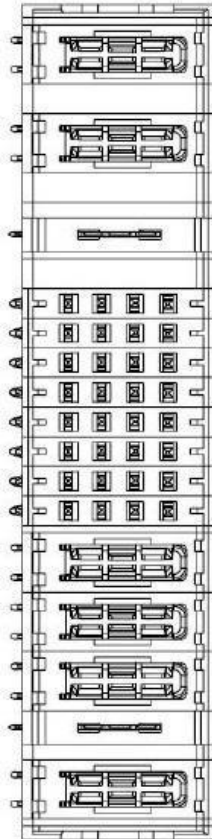
The Internal clock will sync after 32, within tolerance, external clock cycles.

Unit will revert to its internal clock upon any out of tolerance external clock and will require another 32 clocks to re synchronized.

Note: Sync\_in function is optional, please contact factory if required.

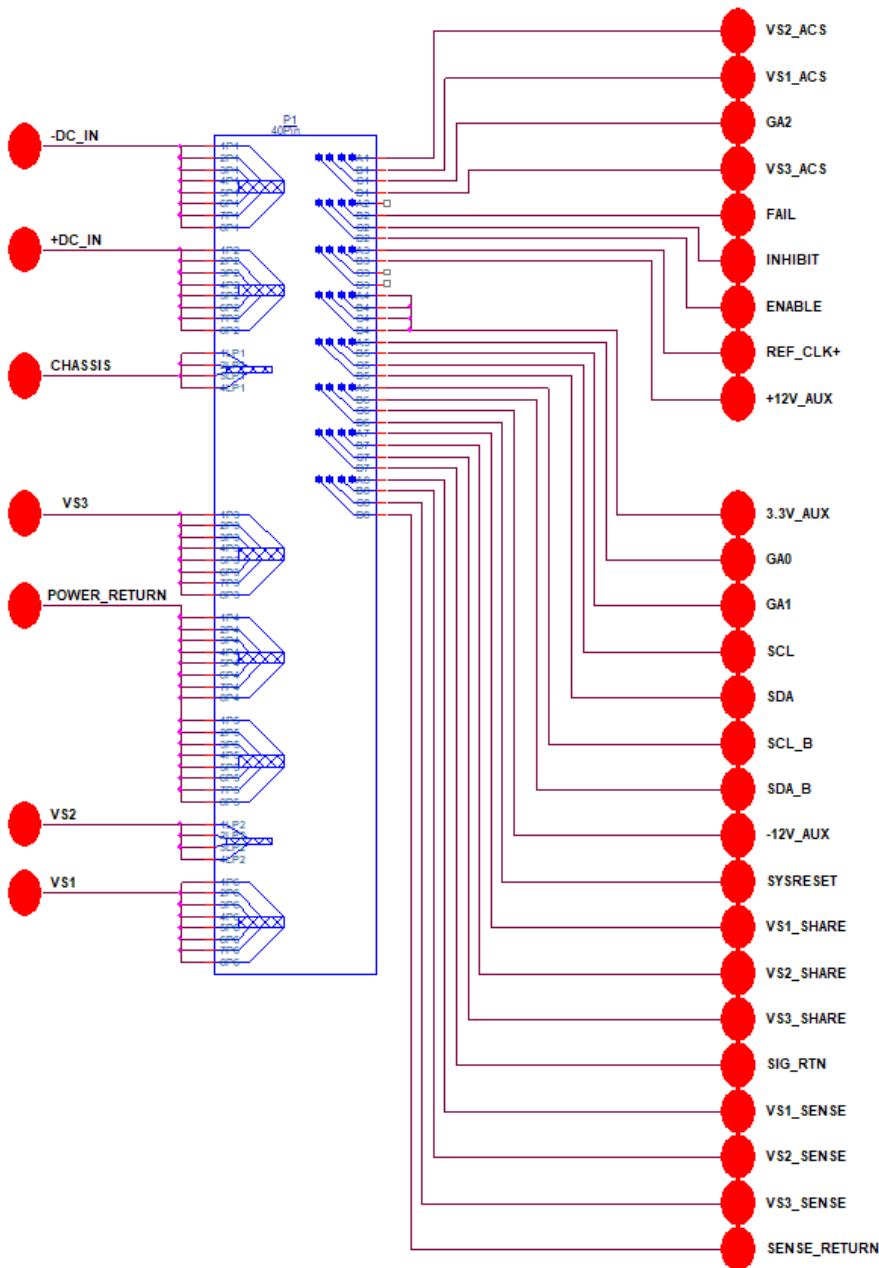
## M4365 SERIES VPX DC/DC POWER SUPPLY

### Pin Assignment



PART NUMBER	ROWS	POWER			SIGNAL								POWER				
		P1	P2	LP1	1	2	3	4	5	6	7	8	P3	P4	P5	LP2	P6
6450849-7	D				Z5	Z5	Z5	Z5	Z5	Z5	Z5	Z5					
	C				Y5	Y5	Y5	Y5	Y5	Y5	Y5	Y5					
	B		TT		R5	R5	R5	R5	R5	R5	R5	R5		TT		TT	
	A			LT	05	05	05	05	05	05	05	05					LT
2ACP+1LP+32S+3HD+1LP+1HDP																	

## M4365 SERIES VPX DC/DC POWER SUPPLY

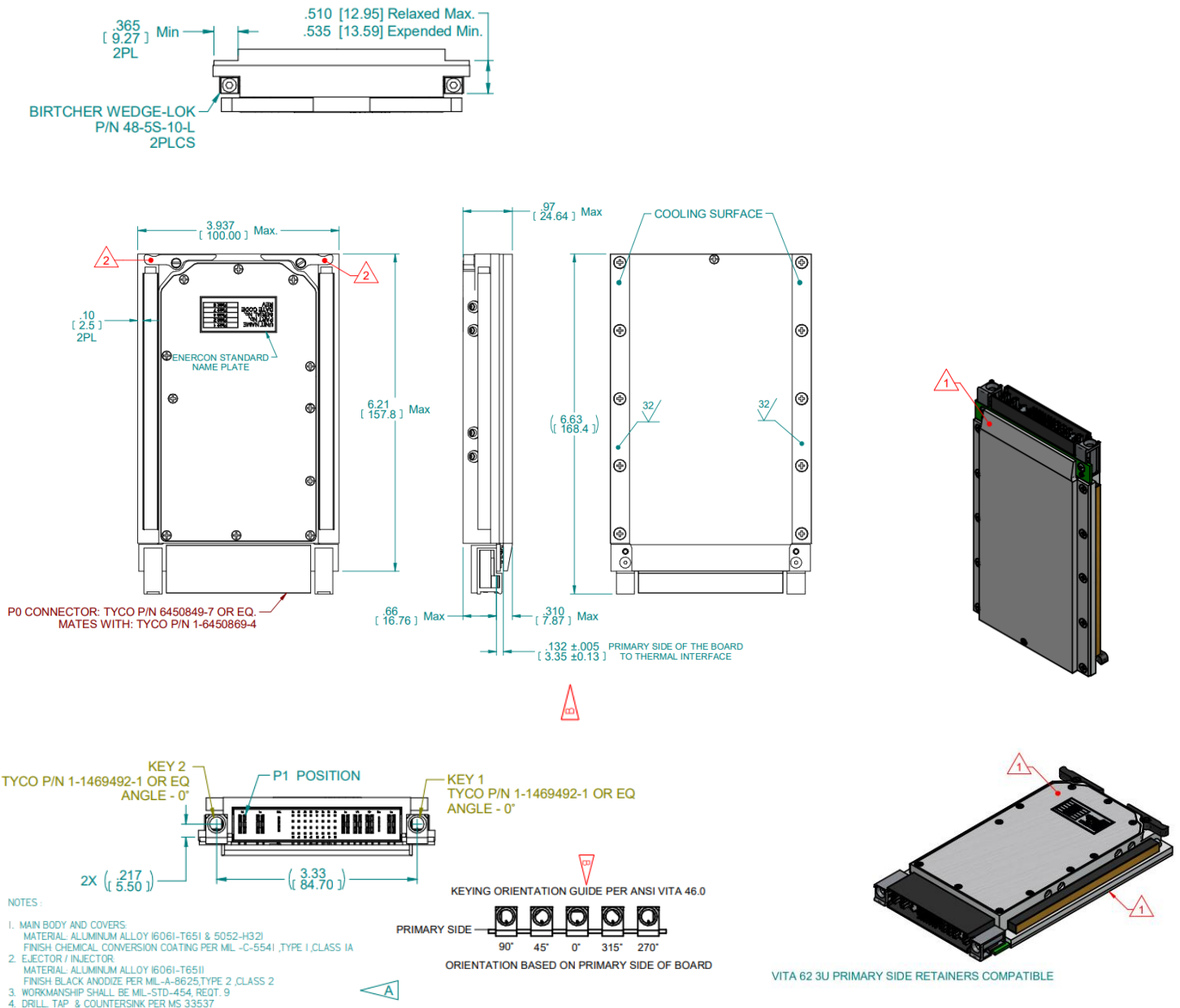


Pin Number	Pin Name
P1	-DC_IN
P2	+DC_IN
LP1	CHASSIS
P3	VS3
P4	POWER_RETURN
P5	POWER_RETURN
LP2	VS2
P6	VS1
A8	VS1_SENSE
B8	VS2_SENSE
C8	VS3_SENSE
D8	SENSE_RETURN
A7	VS1_SHARE
B7	VS2_SHARE
C7	VS3_SHARE
D7	SIG_RTN
A6	SCL_B
B6	SDA_B
C6	-12V_AUX
D6	SYSRESET*
A5	GA0*
B5	GA1*
C5	SCL
D5	SDA
A4	+3.3V_AUX
B4	+3.3V_AUX
C4	+3.3V_AUX
D4	+3.3V_AUX
A3	Sync_IN
B3	+12V_AUX
C3	N.C
D3	N.C
A2	N.C
B2	FAIL*
C2	INHIBIT*
D2	ENABLE*
A1	VS2_ACS
B1	VS1_ACS
C1	GA2*
D1	VS3_ACS



## M4365 SERIES VPX DC/DC POWER SUPPLY

### Outline Drawing



### Notes

- Weight: Approx. 796 g (28.08 oz)

UNLESS OTHERWISE SPECIFIED  
DIMENSIONS ARE IN INCH (MM).  
TOLERANCES ARE:

DECIMALS	ANGLES
.XX±	± 1
.XXX±	0.01
DO NOT SCALE DRAWING	

*Note: Specifications are subject to change without prior notice by the manufacturer.*