

M6169 SERIES

SINGLE-OUTPUT, UP TO 1KW AC/DC POWER SUPPLY, BASE PLATE COOLED

The M6169 converts universal input voltage (85V ac to 265V ac) to DC Output at 1kW.

This unit is sealed to protect against fluids.

This unit can tolerate high level of shocks and vibration.

This unit meets RE102 (24bd μ V/m) as required by MIL-STD-461



M6169 Series– AC/DC Power Supply

THE MAIN FEATURES OF THE M6169 ARE:

- AC/DC Single output power supply up to 1kW
- 85V_{AC}-265V_{AC}/50-60Hz or 90V_{AC}-180V_{AC}/ 400Hz Standard Input version, single-phase
- For extended input version - **Please contact factory for more details**
- High efficiency
- Wide input range
- High power factor
- Input / Output isolation
- Optional - Remote sense compensation
- Can be configure as a charger- **Please contact factory for more details**
- EMI filters included
- Was subject to RE102 and CE102 tests IAW MIL-STD-461
- Inrush Current Limiter
- Sustains high level of shocks and vibration, salt-fog, blowing rain, sand and dust.
- Sealed enclosure
- Non-latching protections:
 - Overload/Short-circuit
 - Output Overvoltage
 - Over Temperature

M6169 Series– AC/DC Power Supply

Standard Models List (for other voltages – consult factory)

| Part number | Input | | Output | | Special features | type | |
|-------------|---|-------------|--------------------|---------|---|------|---|
| | Voltage range | Frequency | Voltage | Current | | A | B |
| M6169100 | 85V _{AC} -265V _{AC} / 1-phase | 50/60/400Hz | 5 V _{DC} | 42 A | Vout ±2% | V | |
| M6169101 | 85V _{AC} -265V _{AC} / 1-phase | 50/60/400Hz | 12 V _{DC} | 42 A | Vout ±2% | V | |
| M6169102 | 85V _{AC} -265V _{AC} / 1-phase | 50/60/400Hz | 24 V _{DC} | 42 A | Vout ±2% | V | |
| M6169103 | 85V _{AC} -265V _{AC} / 1-phase | 50/60/400Hz | 28 V _{DC} | 36 A | Vout ±2% | V | |
| M6169104 | 85V _{AC} -265V _{AC} / 1-phase | 50/60/400Hz | 48 V _{DC} | 21 A | Vout ±2% | V | |
| M6169106 | 85V _{AC} -265V _{AC} / 1-phase | 50/60/400Hz | 28 V _{DC} | 36 A | Parallel operation via output voltage droop. Voltage regulation is ±2%. Vout ±2% | V | |
| M6169200 | 85V _{AC} -265V _{AC} / 1-phase | 50/60/400Hz | 5 V _{DC} | 42 A | | | V |
| M6169201 | 85V _{AC} -265V _{AC} / 1-phase | 50/60/400Hz | 12 V _{DC} | 42 A | | | V |
| M6169202 | 85V _{AC} -265V _{AC} / 1-phase | 50/60/400Hz | 24 V _{DC} | 42 A | | | V |
| M6169203 | 85V _{AC} -265V _{AC} / 1-phase | 50/60/400Hz | 28 V _{DC} | 36 A | | | V |
| M6169204 | 85V _{AC} -265V _{AC} / 1-phase | 50/60/400Hz | 48 V _{DC} | 21 A | | | V |

- Additional standard configurations available. **Contact factory for more details.**
- All of our products can be configured to comply with EU REACH regulations. **Contact factory for more details.**

M6169 Series– AC/DC Power Supply

SPECIFICATIONS:

| | | |
|------------------|-------------------------------------|---|
| AC Input | Voltage Range | Option 1: 85 V _{AC} -265 V _{AC} /50 Hz - 60 Hz / Single-phase Option 2: 90 V _{AC} -180 V _{AC} /400 Hz / Single-phase For extended input version - Please contact factory for more details |
| | Isolation | 1 000 V _{DC} Input to Output 1 000 V _{DC} Input and Case |
| | Spikes | Optional to withstand 1000 V spikes IAW MIL-STD-1399-300B. please consult factory |
| DC Output | Rating | 1 kW, models with nominal output voltage of up to 48VDC and rated current up 36Amp are available (see the Standard Models List on Page 3). |
| | Voltage Regulation | Up to ±2% (no load to full load, –40 °C to +85 °C and over normal input voltage range). |
| | Optional Remote Sense | The SENSE is used to achieve accurate load regulations at load terminals (this is done by connecting the pins directly to the load's terminals). For output voltage above 8V, the use of remote sense has a max limit of 0.25V voltage dropout between converter's output and load terminals. For output voltage below 8V, the use of remote sense has a max limit of 0.5V voltage dropout between converter's output and load terminals. When not used connect SENSE to OUT and SENSE RTN to OUT RTN. |
| | Ripple and Noise | (max. 1%) measured at load across 1 μF and 0.1 μF ceramic capacitors. |
| | Isolation | 200 V _{DC} Output and Case |
| | Current Limit & Overload | Output turns off and on periodically (hiccup) until fault is condition removed. Protection threshold set at 120% ± 10% of maximum current Optional: Continuous protection (10 to 30% above maximum current) for unlimited time. please consult factory |
| | Efficiency | Up to 85-89% - typical (nominal input voltage, full load, room temperature) |
| | Overvoltage Protection | <ul style="list-style-type: none"> • Active Over-Voltage Protection Internal control shuts output down if voltage exceeds 110% ± 5% of nominal. • Passive Over-Voltage Protection A transorb, rated to 120% ± 10% of nominal voltage, is placed across the output. |

M6169 Series– AC/DC Power Supply

| | | |
|--|----------------------------------|--|
| | Over Temp. Protection | Unit shuts down if baseplate temperature exceeds 100 ± 5 °C. Automatic recovery upon cooldown to below 95 ± 5 °C. |
|--|----------------------------------|--|

Specifications (Cont.):

| | | |
|---|---|--|
| Environment Designed to meet MIL-STD- 810F | Temperature | Methods 501.4 & 502.4 Operating: -40 °C to $+85$ °C (at baseplate). Optional operating -55 please consult factory. Storage: -55 °C to $+125$ °C (ambient) |
| | Humidity | Method 507.6 test Procedure 2 |
| | Rain | Method 506.6 Procedure 1,2 |
| | Sand & Dust | Method 510.6 Procedure 1 |
| | Salt-fog | Method 509.6 |
| | Altitude | Method 500.4 Procedures I – up to 70,000 ft. (non-operational) Procedure II – up to 40,000 ft. (operational) Note: can be operational. |
| | Temperature Shock | Method 503.6 |
| | Mechanical Shock | Method 516.5 Procedure I 30 g, 11 ms terminal peak saw-tooth |
| | *See note page 6 Vibration | Method 514.5 Procedure I Category 24 - General minimum integrity exposure |
| | Temperature/ Altitude DE- RATING | DE-RATE temperature linearly with altitude with a slope of -9 °C/ 5000 FT TBR referenced to the maximum hot operating temperature at MSL |
| | Fungus | Method 508.7 |
| IP rating | Designed to meet IP67 | |
| EMI | Designed to meet* MIL-STD-461F | CS101, CS114, CS115, CS116,, RS103 (50V/m), CE101-4 curve #1, RE101-1 and RS101. |
| | Meet * MIL-STD-461F | CE102-1 (115V limit), RE102 (24bd μ V/m) |
| Reliability | 150,000 hours, calculated per MIL-STD-217F Notice 2 at $+85$ °C baseplate, Ground Fixed environment. | |

M6169 Series– AC/DC Power Supply

| | |
|--------------------|--|
| Form factor | 7.25" wide, 3.1" high and 11" deep. For detailed dimensions and tolerances see Drawing: M6169001 |
| Weight | 10.5 lb. Typical |

* Compliance dependent on specific configuration and is achieved when using shielded output cables cable.

MEETS THE FOLLOWING VIBRATION PROFILES:

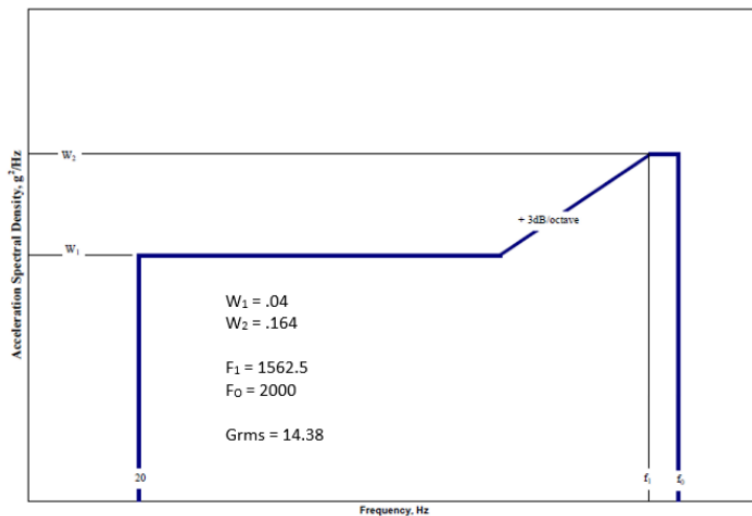

Figure 11 - Random Vibration Spectral Density Profile

TEST RESULTS RE102

Plot 1.2: RE102 test results within 2 – 30 MHz, vertical polarization

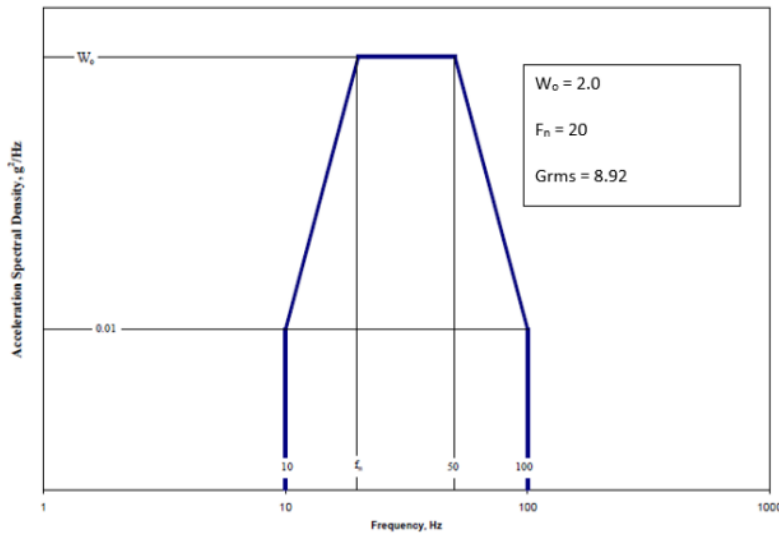
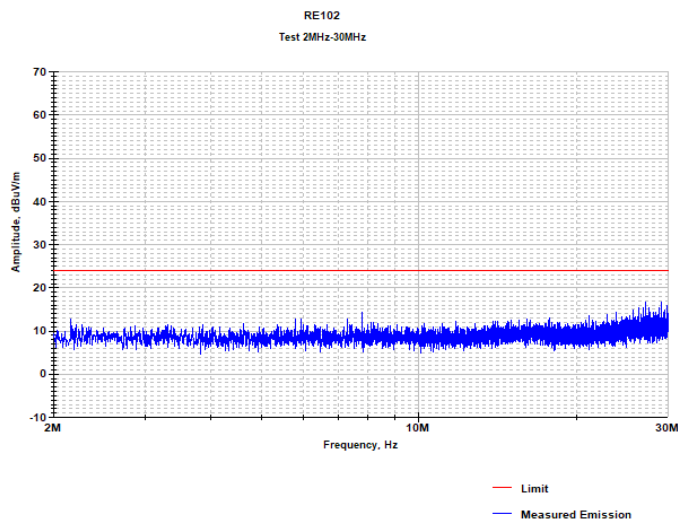

Figure 12 - Buffeting Vibration Spectral Density Profile

Display line is Limit

Plot 1. 4: RE102 test results within 30 – 200 MHz, vertical polarization



Display line is Limit

M6169 Series– AC/DC Power Supply

Plot 11.15: RE102 test results within 30 – 200 MHz, horizontal polarization

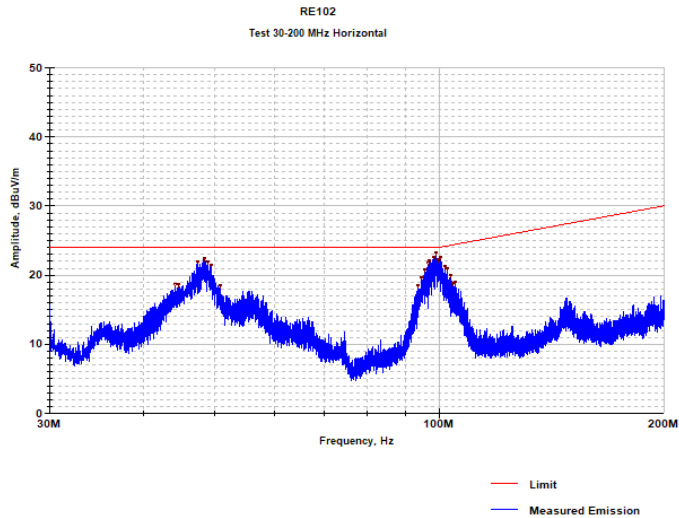

Plot 11.19: RE102 test results within 200 – 1000 MHz, vertical polarization

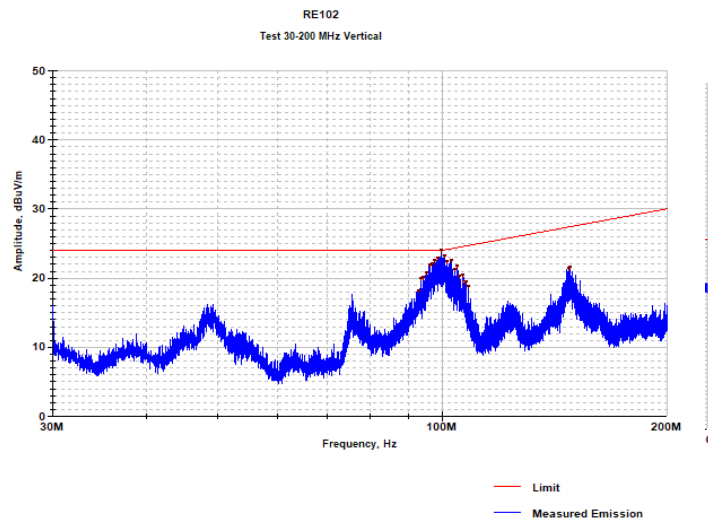

Display line is Limit

M6169 Series– AC/DC Power Supply

Plot 11.21: RE102 test results within 200 – 1000 MHz, horizontal polarization

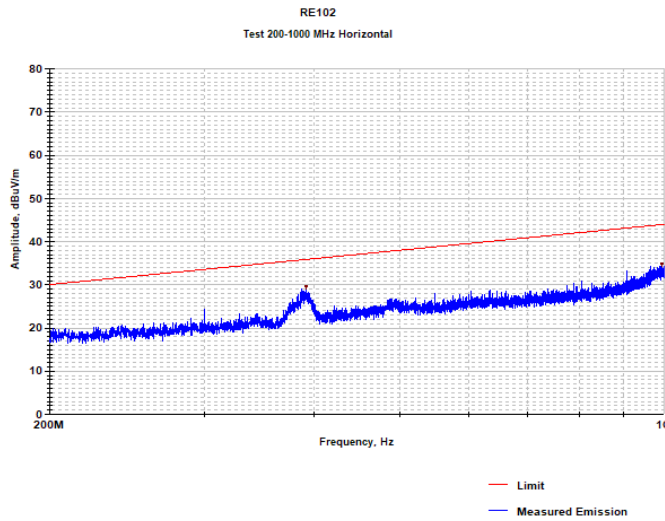

Plot 11.25: RE102 test results within 1000 – 18000 MHz, vertical polarization

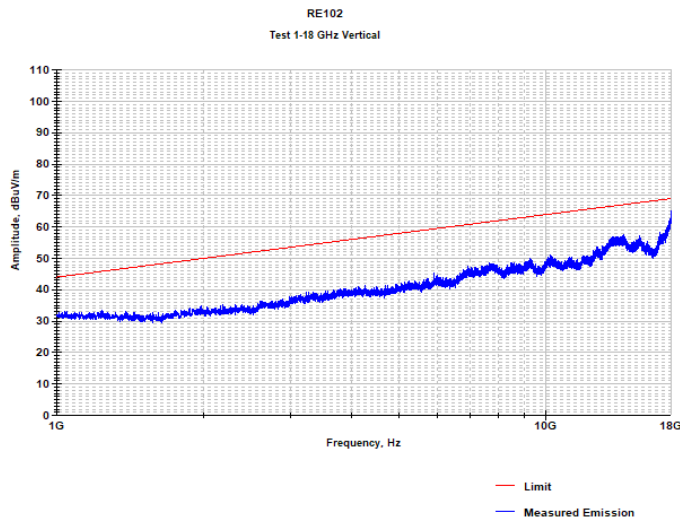

Display line is Limit

M6169 Series– AC/DC Power Supply

Plot 11.25: RE102 test results within 1000 – 18000 MHz, horizontal polarization

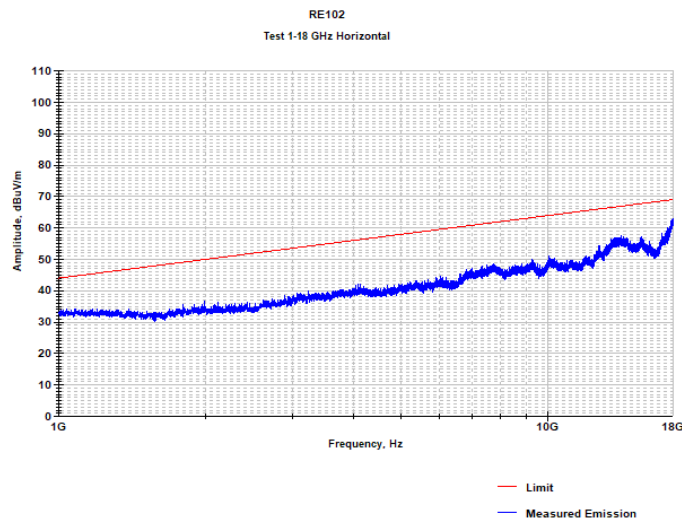

Display line is Limit

M6169 Series– AC/DC Power Supply

RE102 test results within 30 – 200 MHz, vertical polarization

| Frequency (MHz) | Measured Emission (dBuV/m) | Limit (dBuV/m) | Delta (dB) |
|-----------------|----------------------------|----------------|------------|
| 92.713 | 18.10 | 24.00 | -5.90 |
| 93.393 | 19.86 | 24.00 | -4.14 |
| 94.277 | 20.14 | 24.00 | -3.86 |
| 95.093 | 20.75 | 24.00 | -3.25 |
| 96.215 | 21.91 | 24.00 | -2.09 |
| 96.963 | 21.99 | 24.00 | -2.01 |
| 97.660 | 22.48 | 24.00 | -1.52 |
| 98.578 | 22.80 | 24.00 | -1.20 |
| 99.445 | 24.00 | 24.00 | -0.00 |
| 100.482 | 23.19 | 24.04 | -0.85 |
| 101.179 | 22.37 | 24.10 | -1.73 |
| 102.913 | 22.59 | 24.25 | -1.66 |
| 103.950 | 21.24 | 24.34 | -3.09 |
| 104.562 | 21.71 | 24.39 | -2.68 |
| 105.174 | 20.27 | 24.44 | -4.17 |
| 106.330 | 20.37 | 24.53 | -4.16 |
| 106.942 | 19.39 | 24.58 | -5.19 |
| 107.554 | 19.51 | 24.63 | -5.12 |
| 108.336 | 18.75 | 24.69 | -5.95 |
| 147.538 | 21.43 | 27.37 | -5.94 |
| 148.286 | 21.57 | 27.41 | -5.84 |

M6169 Series– AC/DC Power Supply

RE102 test results within 30 – 200 MHz, horizontal polarization

| Frequency (MHz) | Measured Emission (dBuV/m) | Limit (dBuV/m) | Delta (dB) |
|-----------------|----------------------------|----------------|------------|
| 44.178 | 18.5 | 24.0 | -5.5 |
| 44.688 | 18.5 | 24.0 | -5.5 |
| 47.425 | 21.9 | 24.0 | -2.1 |
| 48.326 | 22.5 | 24.0 | -1.5 |
| 48.921 | 21.8 | 24.0 | -2.2 |
| 49.431 | 21.4 | 24.0 | -2.6 |
| 50.791 | 18.4 | 24.0 | -5.6 |
| 93.665 | 18.4 | 24.0 | -5.6 |
| 94.549 | 19.6 | 24.0 | -4.4 |
| 95.433 | 20.8 | 24.0 | -3.2 |
| 96.419 | 21.6 | 24.0 | -2.4 |
| 96.929 | 22.1 | 24.0 | -1.9 |
| 98.187 | 22.5 | 24.0 | -1.5 |
| 98.901 | 23.1 | 24.0 | -0.9 |
| 99.462 | 22.3 | 24.0 | -1.7 |
| 100.397 | 22.5 | 24.0 | -1.6 |
| 101.689 | 21.2 | 24.1 | -2.9 |
| 102.267 | 20.9 | 24.2 | -3.3 |
| 103.423 | 19.9 | 24.3 | -4.4 |
| 104.239 | 18.7 | 24.4 | -5.6 |
| 104.919 | 18.9 | 24.4 | -5.5 |

TEST RESULTS CE102

Plot 5.10: CE102 test results in 10 kHz-10.0 MHz range, PHASE 115 VAC

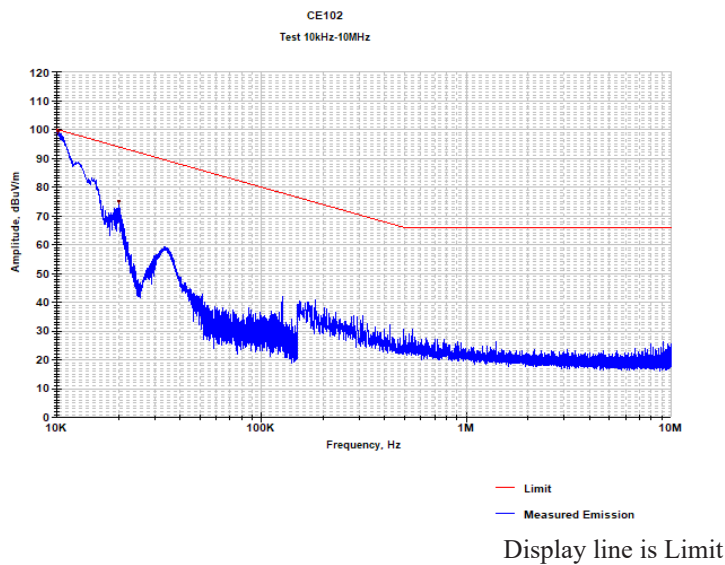

Plot 5.12: CE102 test results in 10 kHz-10.0 MHz range, NEUTRAL 115 VAC

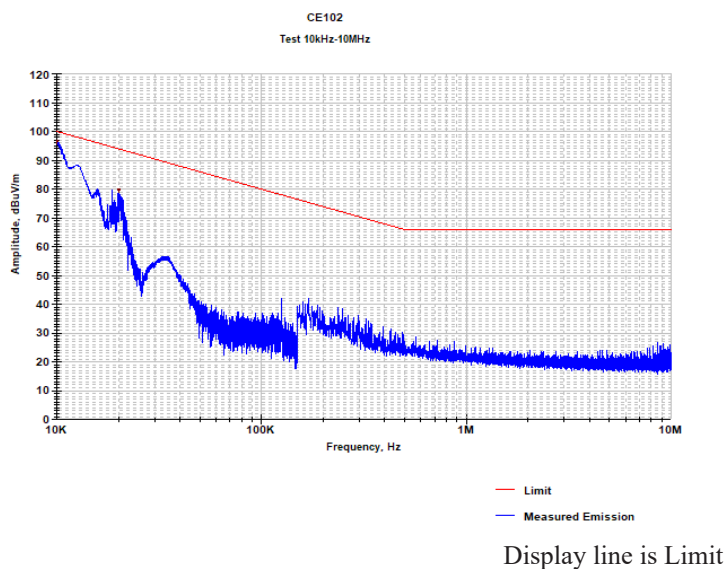

M6169 Series– AC/DC Power Supply

PIN ASSIGNMENT: J1 - INPUT CONNECTOR

Connector type: D38999/24WC4PN (4#16 PINS) or eq.

Mates with: D38999/26WC4SN or eq.

| Pin # | Function |
|-------|---------------------|
| A | PHASE |
| B | NEUTRAL |
| C | CHASSIS GND |
| D | (SPARE) NOT CONNECT |

CHASSIS Note: Chassis PIN

This pin is connected to the converter's chassis.

M6169 Series– AC/DC Power Supply

PIN ASSIGNMENT: J2 - OUTPUT CONNECTOR - OPTION A

Connector type: D38999/24WE6SN (6#12 SOCKETS) or eq.

Mates with: D38999/26WE6PN or eq.

| Pin # | Function |
|-------|-------------|
| A | VOUT |
| B | VOUT RTN |
| C | CHASSIS GND |
| D | VOUT |
| E | VOUT RTN |
| F | CHASSIS GND |

Note: All pins with identical function/designation should be connected together for optimal performance.

CHASSIS Note: Chassis PIN

This pin is connected to the converter's chassis.

PIN ASSIGNMENT: J2 - OUTPUT CONNECTOR - OPTION B

Connector type: D38999/24WE6SN (6#12 SOCKETS) or eq.

Mates with: D38999/26WE6PN or eq.

| Pin # | Function |
|-------|-----------|
| A | VOUT |
| B | VOUT RTN |
| C | SENSE |
| D | VOUT |
| E | VOUT RTN |
| F | SENSE RTN |

Note: All pins with identical function/designation should be connected together for optimal performance.

M6169 Series– AC/DC Power Supply

PIN ASSIGNMENT: J2 - OUTPUT CONNECTOR - OPTION C

Connector type: D38999/24WE6SN (6#12 SOCKETS) or eq.

Mates with: D38999/26WE6PN or eq.

| Pin # | Function |
|-------|----------|
| A | VOUT |
| B | VOUT RTN |
| C | VOUT |
| D | VOUT |
| E | VOUT RTN |
| F | VOUT RTN |

Sense lines are tied internally

Note: All pins with identical function/designation should be connected together for optimal performance.

M6169 Series– AC/DC Power Supply

BLOCK DIAGRAM – OPTION A

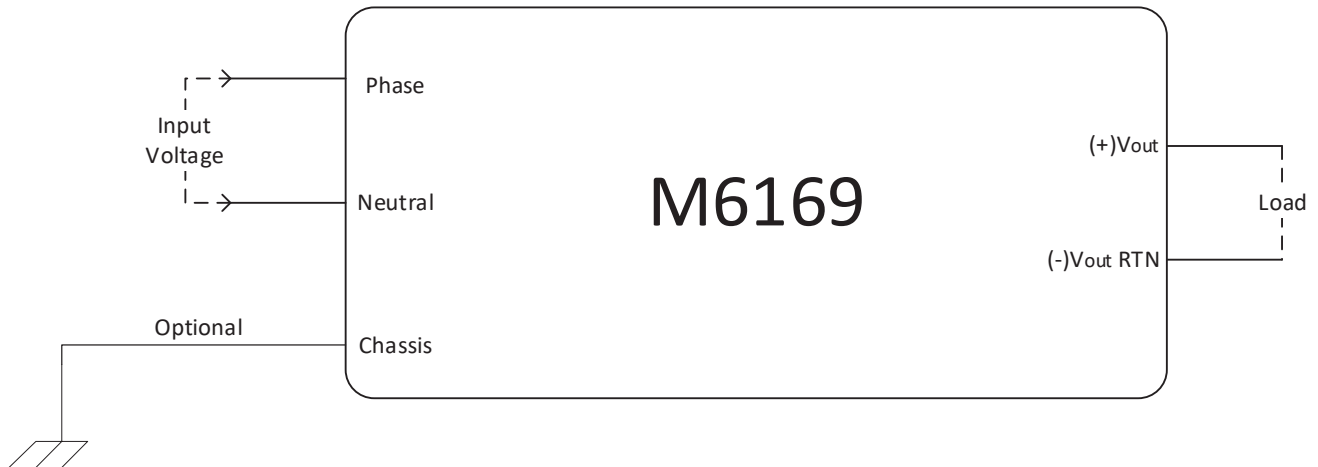

BLOCK DIAGRAM – OPTION B

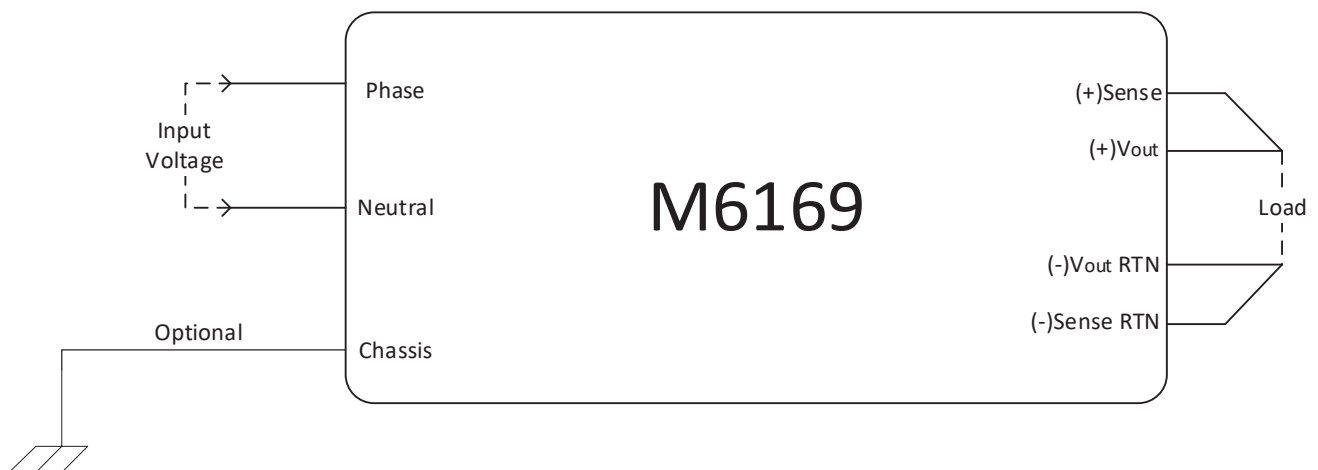

BLOCK DIAGRAM – OPTION C

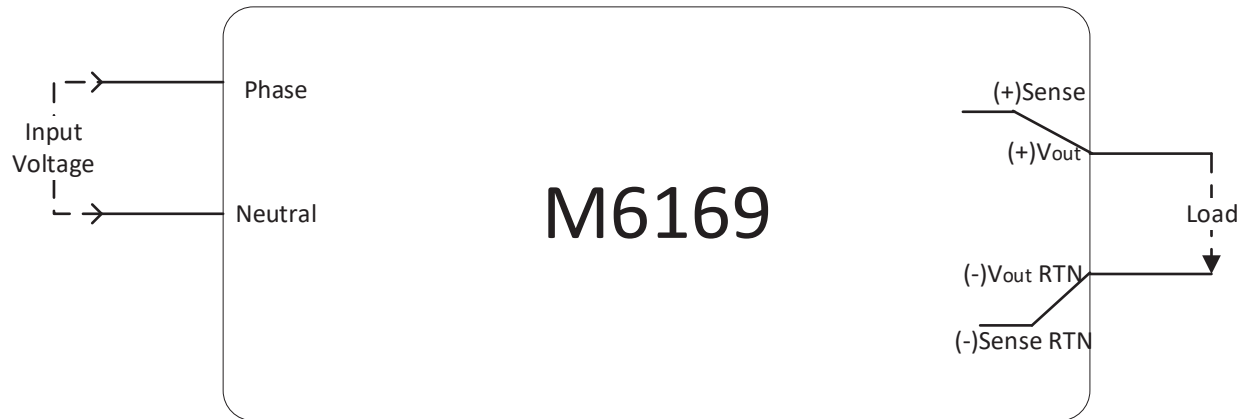

M6169 Series— AC/DC Power Supply

OUTLINE DRAWING:

For detailed dimensions and tolerances see Drawing: M6169001

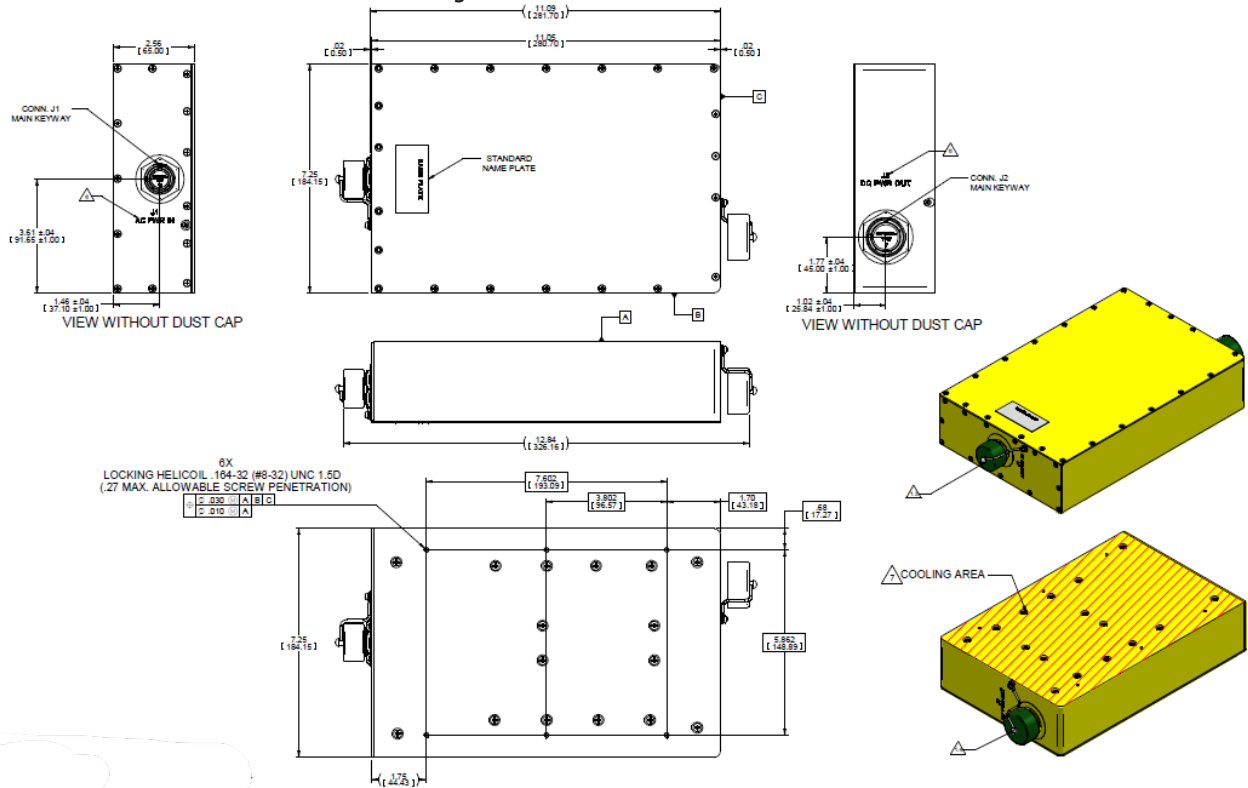

NOTES:

1. CONNECTORS:
 - 1.1. J1- CONN. AC PWR IN, P/N D38999/24WC4PN OR EQ.
 - 1.2. J2- CONN. DC PWR OUT, P/N D38999/24WE8SN OR EQ.
 - 1.3. CONN. J1 DUST CAP, P/N D38999/33W13R OR EQ.
 - 1.4. CONN. J2 DUST CAP, P/N D38999/33W17R OR EQ.
2. MATERIAL: AL 6061-T651, AL 5052-H32, OR EQ.
3. COATINGS:
 - 3.1. CHROMATE CONVERSION COATING PER MIL-DTL-5541 TYPE II CLASS 3 CLEAR.
4. WORKMANSHIP SHALL BE MJL-STD-454, REQ. 9.
5. MAX WEIGHT: 10.5 LBS.
6. ENGRAVING:
 - 6.1. CHARACTER HEIGHT: .15 IN.
 - 6.2. CHARACTER DEPTH: .02 IN.
 - 6.3. FONT: ARIAL.
 - 6.4. CHARACTER ARE CENTRALLY LOCATED.
 - 6.5. FILL ENGRAVING WITH BLACK LUSTERLESS EPOXY PAINT, COLOR PER FED-STD 595 NO. 37038.
7. COOLING:
 - HEAT DISSIPATION AREA- 80.11 [IN²]

Please note: Specifications are subject to change without prior notice by the manufacturer.