

M8139 SERIES

TRIPLE-OUTPUTS, 60W DC TO DC POWER SUPPLY

The M8139 is a series of mechanically robust, base-plate cooled, high performance, power supplies, designed for Ground Mobile (MIL-STD-1275), Airborne (MIL-STD-704) and other Hi-Reliability applications where 28VDC has to be converted to a tightly regulated, filtered and protected DC output.

TYPE A



TYPE B

M8139 Series– DC/DC Power Supply

Standard Models List (for other voltages – consult factory)

Part number	Input	Output 1		Output 2		Output 3		Type	
	Voltage range	Voltage	Current	Voltage	Current	Voltage	Current	A	B
M8139100	18 to 48 V _{DC}	5 V _{DC}	6 A	3.3 V _{DC}	2 A	12 V _{DC}	1 A	V	
M8139101	18 to 48 V _{DC}	12 V _{DC}	3 A	5V _{DC}	1.25 A	12 V _{DC}	1 A		V
M8139102	18 to 48 V _{DC}	5 V _{DC}	5 A	15 V _{DC}	1 A	15 V _{DC}	1 A	V	

- Regulation at output #2 and output #3 up to 2% of nominal voltage, peak-to-peak when output is 3.3V or 5V.
- Additional standard configurations available. **Contact factory for more details.**
- All of our products can be configured to comply with EU REACH regulations. **Contact factory for more details.**

M8139 Series– DC/DC Power Supply

THE MAIN FEATURES OF THE M8139 ARE:

- DC/DC Triple outputs power supply up to 60W
- 18 to 48VDC Standard Input version
- For extended input version - **Please contact factory for more details**
- No damage (may shutdown) due to abnormal transients IAW MIL-STD-1275A (100 V / 50 ms) and MIL-STD-704A (80 V / 0.1 s)
- High efficiency – up to 80% (depending on output voltage).
- Full galvanic isolation between Input, Chassis and Outputs
- External Inhibit (On/Off)
- Fixed switching freq. (250 kHz)
- EMI filters included
- Remote sense compensation (for type A at output #1)
- Indefinite short circuit protection with auto-recovery
- Over-voltage protection
- Over temperature shutdown with auto-recovery
- High density
- Conduction cooled via the baseplate
- J-STD-001B and IPC-610A Class-3 workmanship
- Conformal Coating per MIL-I-46058C and IPC-CC-830

M8139 Series– DC/DC Power Supply

SPECIFICATIONS:

DC Input	Voltage Range	Normal range: 18 to 48 V _{DC} No damage (may shutdown) due to abnormal transients IAW MIL-STD-1275A (100 V / 50 ms) and MIL-STD-704A (80 V / 0.1 s) For extended input version - Please contact factory for more details
	Isolation	Input to Output: 200 VDC Input to Case: 200 VDC
DC Output	Rating	See table on page 8
	Voltage Regulation	Better than or equal to ±1% (low to high line voltage, no load to full load, –55 °C to +85 °C at baseplate).
	Remote Sense for type A out 1	The SENSE 1 is used to achieve accurate load regulations at load terminals (this is done by connecting the pins directly to the load's terminals). For output voltage above 8V, the use of remote sense has a max limit of 0.25V voltage dropout between converter's output and load terminals. For output voltage below 8V, the use of remote sense has a max limit of 0.5V voltage dropout between converter's output and load terminals. When not used connect SENSE 1 to OUT 1 and SENSE 1 RTN to OUT 1 RTN.
	Ripple	Less than 50 mVp-p, typical (max. 1% of output voltage)
	Isolation	Output to Case: 100 VDC
	Current Limit & Overload	Continuous protection for unlimited time Overload/short-circuit *If output current is higher than 1.5A and there is short due to failure, when the failure is removed the load will be 50%.
	Efficiency	Up to 80%, depending on output voltage.
	Overvoltage Protection	Passive transorb, chosen at 120% ± 10% of nominal voltage.
Over Temp. Protection	Shutdown if base plate temperature rises above +105 °C ± 5 °C. Auto recovery when baseplate cools down to +95 °C ± 5 °C.	

M8139 Series– DC/DC Power Supply

Specifications (Cont.):

Control & Indication	<i>INHIBIT Input</i>	The INHIBIT signal is used to turn the power supply ON and OFF. TTL “1” or OPEN – Power supply active (output turned on). TTL “0” or SHORT to Signal RTN – Power supply inhibited (output turned off). If this function is not required, leave this pin unconnected. This signal is referenced to SIGNAL RTN (pin 17)
	<i>SIGNAL RTN</i>	INHIBIT and SYNC signals are referenced to this pin. This pin is referenced to IN RTN (pins 7, 8, 22 and 23).
Environment Designed to meet MIL-STD-810F	<i>Temperature</i>	Methods 501.4 & 502.4 Operating: –55 °C to +85 °C (at baseplate) Storage: –55 °C to +125 °C (ambient)
	<i>Humidity</i>	Method 507.4 Up to 95% RH
	<i>Salt-fog</i>	Method 509.4
	<i>Altitude</i>	Method 500.4 Procedures I – Storage/Air transport: up to 70,000 ft. (non-operational) Procedure II – Operation/Air Carriage: up to 70,000 ft. (operational)
	<i>Mechanical Shock</i>	Method 516.5 Procedure I 50 g / 11 ms terminal peak half-sine shock pulse
	<i>Vibration</i>	Method 514.5 Procedure I 14.76 g _{rms} 20-2000 Hz for 500 seconds at each of 3 perpendicular axes.
	<i>Fungus</i>	Does not support fungus growth, in accordance with the guidelines of MIL-STD-454, Requirement 4-
EMI	<i>MIL-STD-461F</i>	Designed to meet* MIL-STD-461F CE101, CE102, CS101, CS114, CS115, CS116, RE101, RE102, RS101, RS103
Reliability	150,000 hours, calculated per MIL-HDBK-217F Notice 2 at +85 °C baseplate, Ground Fix conditions.	
Cooling Requirements	The M8139 is a baseplate cooled unit. The base of the M8139 should be thermally attached to a suitable heatsink that maintains it below +85 °C.	
Form factor	2.16" wide, 0.50" high and 3.10" deep. For detailed dimensions and tolerances see Drawing: M8139001 M8139002	
Weight	Type A: 100 gram, Type B: TBD	
Connectors	See Page 8	

* Compliance achieved with 5µH LISN, shielded harness and static resistive load.

M8139 Series– DC/DC Power Supply

OPERATIONAL BLOCK DIAGRAM TYPE A

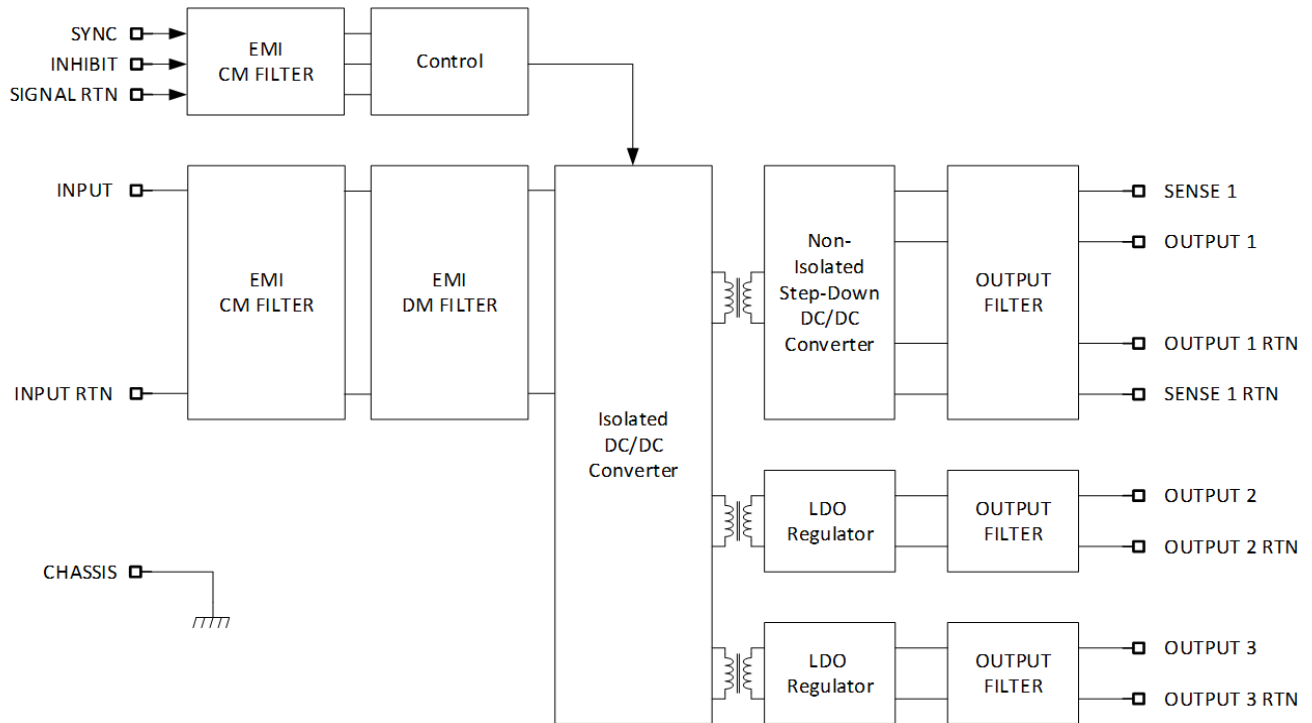

Type A - Outputs Range

Output #	Voltage Range	Current Range	Output Regulation	Power Range
1	1 to 5 V _{DC}	0 to 8 A	±1%	0 to 40 W
2	1.8 to 24 V _{DC}	0 to 3 A	±2%	0 to 20 W
3	1.8 to 24 V _{DC}	0 to 1.25 A	±2%	0 to 20 W
Total				0 to 60 W

M8139 Series– DC/DC Power Supply

OPERATIONAL BLOCK DIAGRAM TYPE B

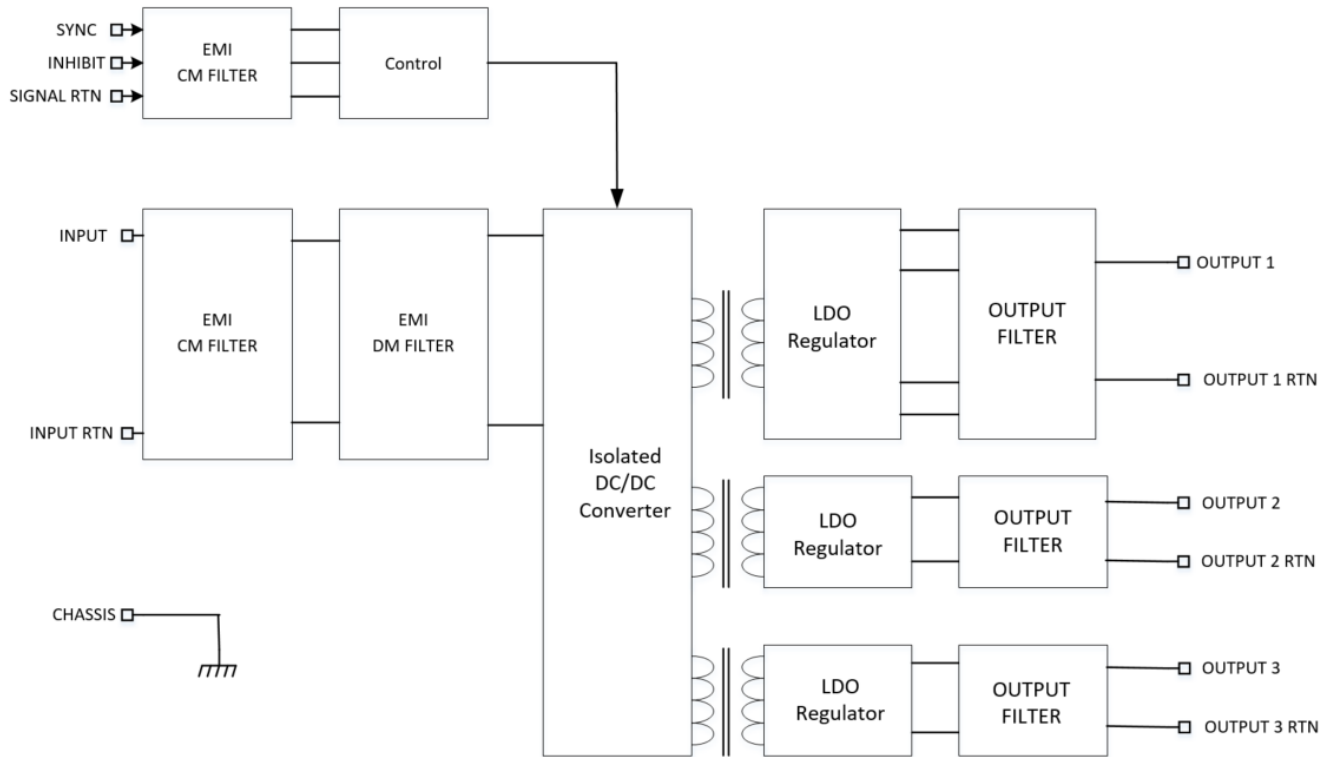

Type B - Outputs Range

Output #	Voltage Range	Current Range	Output Regulation	Power Range
1	1.5 to 24 V _{DC}	0 to 3 A	±1%	0 to 24 W
2	1.5 to 24 V _{DC}	0 to 1.25 A	±2%	0 to 18 W
3	1.5 to 24 V _{DC}	0 to 1.25 A	±2%	0 to 18 W
Total				0 to 60 W

M8139 Series– DC/DC Power Supply

PIN ASSIGNMENT: TYPE A

Connector type: Airborn RM272-030-312-2900 or eq.

Mates with: Airborn RM242-030-241-5900 (solder cup terminations) or RM242-030-571-5900 (#20-22 AWG crimp contacts) or eq.

Pin No.	Function	P		Pin No.	Function	P	
1	INHIBIT	+	⊖	16	SYNC	+	⊖
2	CHASSIS	0	⊙	17	SIGNAL RTN	-	⊖
3	OUT 2 RTN	-	⊙	18	OUT 2 RTN	-	⊙
4	OUT 2	+	⊙	19	OUT 2	+	⊙
5	OUT 3	+	⊙	20	OUT 3	+	⊙
6	OUT 3 RTN	-	⊙	21	OUT 3 RTN	-	⊙
7	IN RTN	-	⊙	22	IN RTN	-	⊙
8	IN RTN	-	⊙	23	IN RTN	-	⊙
9	IN	+	⊙	24	IN	+	⊙
10	IN	+	⊙	25	IN	+	⊙
11	SENSE 1	+	⊙	26	OUT 1	+	⊙
12	OUT 1	+	⊙	27	OUT 1	+	⊙
13	OUT 1	+	⊙	28	OUT 1 RTN	-	⊙
14	OUT 1 RTN	-	⊙	29	OUT 1 RTN	-	⊙
15	OUT 1 RTN	-	⊙	30	SENSE 1 RTN	-	⊙

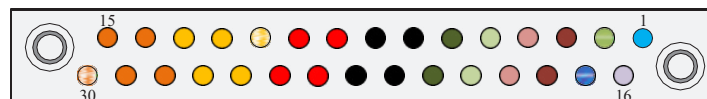

Note: All pins with identical function/designation should be connected together for optimal performance.

CHASSIS Note: The CHASSIS pin allows additional connection of unit's chassis to system ground.

M8139 Series– DC/DC Power Supply

PIN ASSIGNMENT: TYPE B

Connector type: Airborn RM272-030-312-2900 or eq.

Mates with: Airborn RM242-030-241-5900 (solder cup terminations) or RM242-030-571-5900 (#20-22 AWG crimp contacts) or eq.

Pin No.	Function	P	
1	INHIBIT	+	⊖
2	CHASSIS	0	●
3	OUT 2 RTN	-	●
4	OUT 2	+	●
5	OUT 3	+	●
6	OUT 3 RTN	-	●
7	IN RTN	-	●
8	IN RTN	-	●
9	IN	+	●
10	IN	+	●
11	OUT 1	+	●
12	OUT 1	+	●
13	OUT 1	+	●
14	OUT 1 RTN	-	●
15	OUT 1 RTN	-	●
16	SYNC	+	⊖
17	SIGNAL RTN	-	●
18	OUT 2 RTN	-	●
19	OUT 2	+	●
20	OUT 3	+	●
21	OUT 3 RTN	-	●
22	IN RTN	-	●
23	IN RTN	-	●
24	IN	+	●
25	IN	+	●
26	OUT 1	+	●
27	OUT 1	+	●
28	OUT 1 RTN	-	●
29	OUT 1 RTN	-	●
30	OUT 1 RTN	-	●

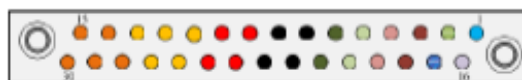

Note: All pins with identical function/designation should be connected together for optimal performance.

CHASSIS Note: The CHASSIS pin allows additional connection of unit's chassis to system ground.

M8139 Series— DC/DC Power Supply

OUTLINE DRAWING TYPE A:

For detailed dimensions and tolerances see Drawing: M8139001

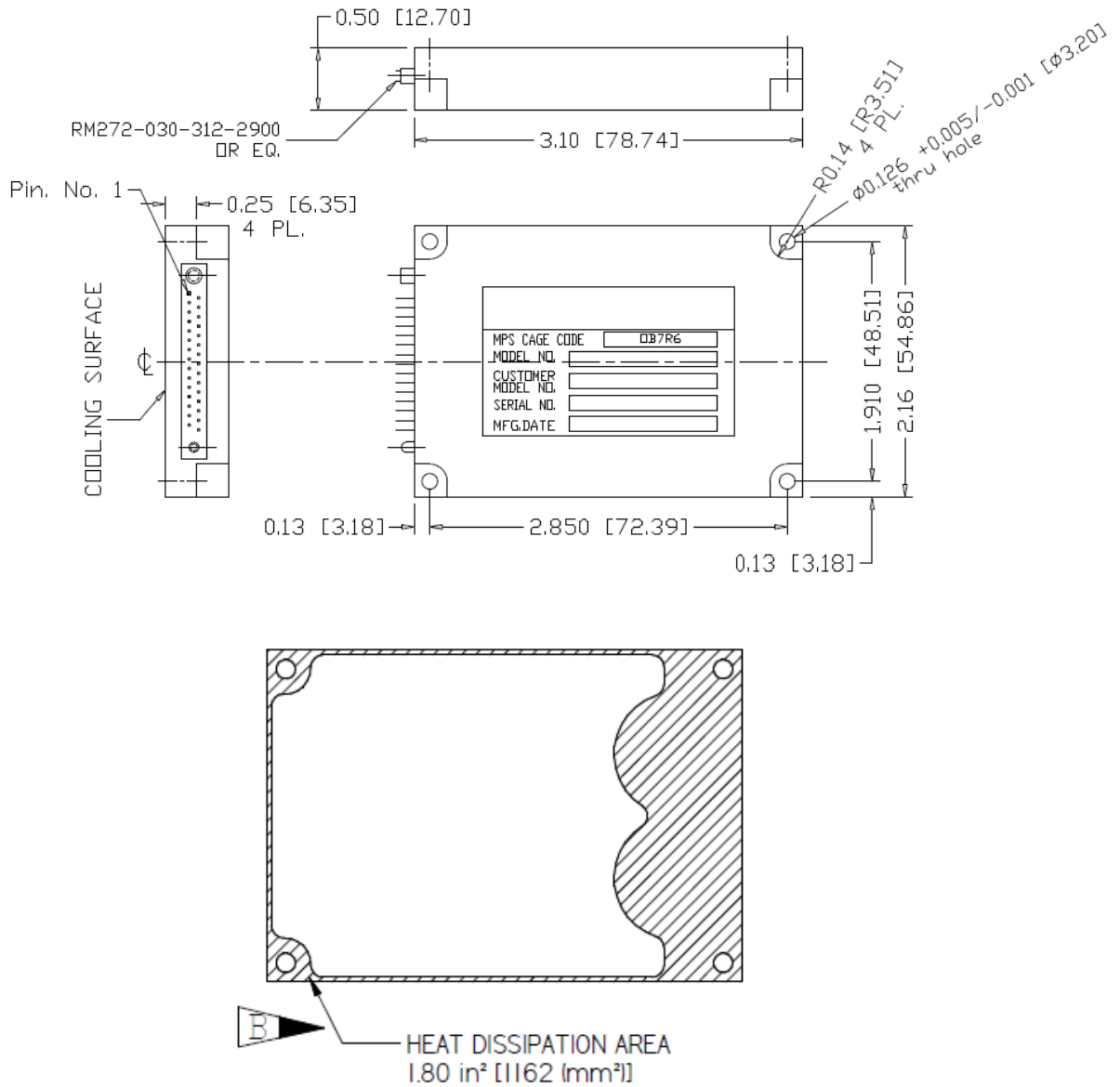

NOTES :

1. HEAT DISSIPATION AREA - TOTAL AREA 1.8 SQ. IN.
2. WORKMANSHIP SHALL BE MIL-STD-454, REQT. 9
3. DRILL, TAP & COUNTERSINK PER NASM33537
4. MTL. AL 6061-T651& AL 5052-H32
5. CONVERSION COATING PER MIL -C-5541 CL 1A

M8139 Series– DC/DC Power Supply

OUTLINE DRAWING TYPE B:

For detailed dimensions and tolerances see Drawing: M8139002

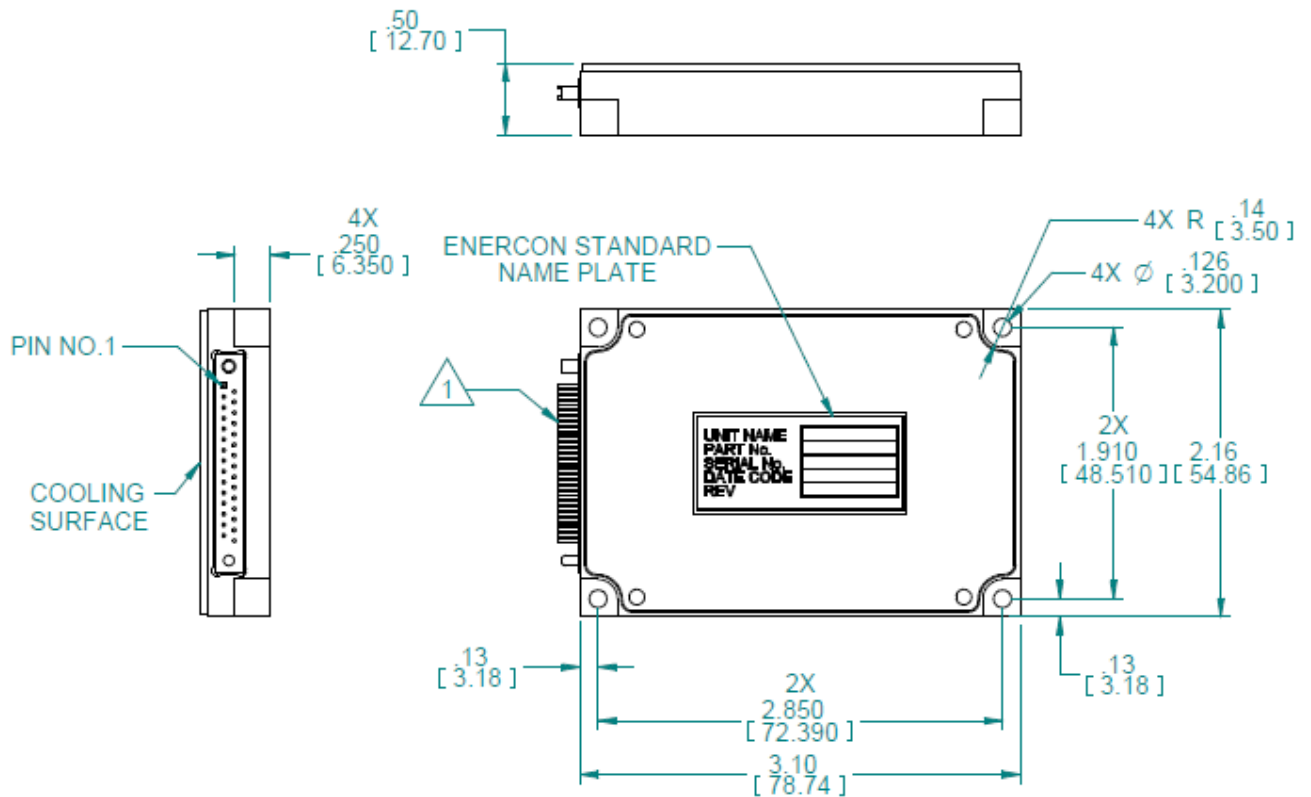

HEAT DISSIPATION AREA
4060 MM² [6.29 IN²]

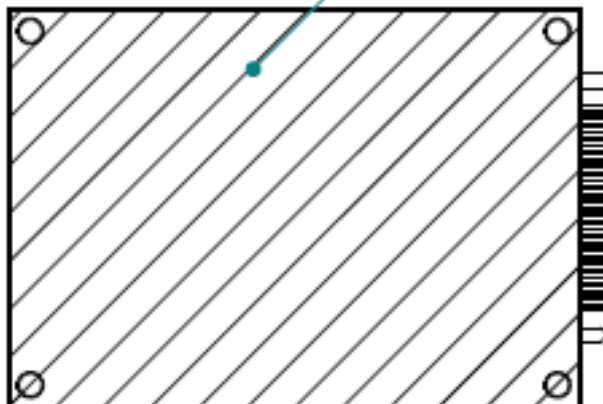

GENERAL TOLERANCES

Dimensions are in inches [mm]

.XX ± .01 [0.25]

.XXX ± .005 [0.127]

ANGLES ± 0.5°

Note: Specifications are subject to change without prior notice by the manufacturer.