

2M MICRO MINIATURE PYTHON

LOW PROFILE EMI/RFI PLUG AND BACKSHELL COMBO

PDS-252-2

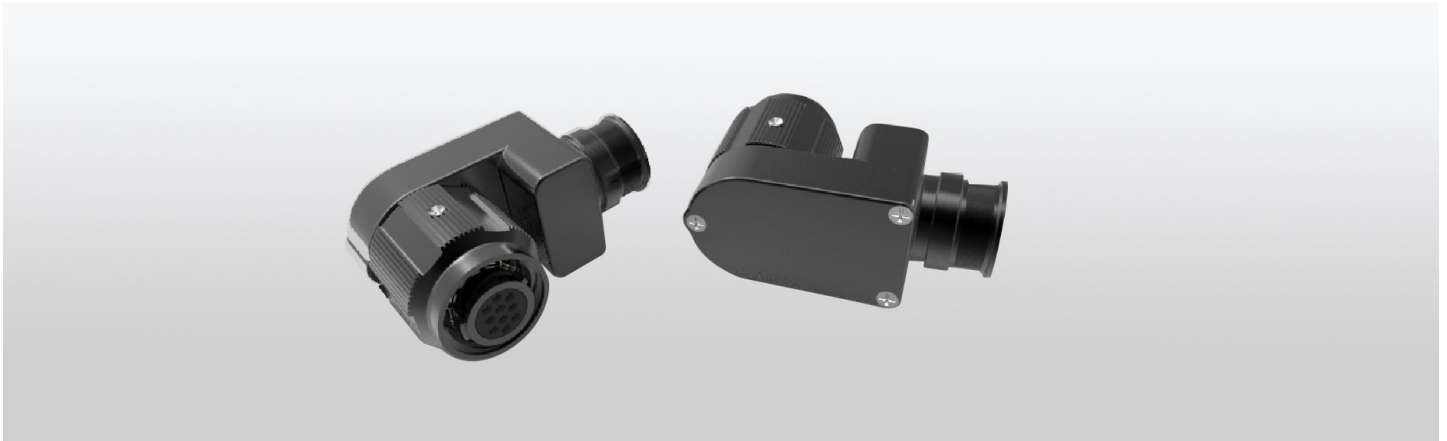

OVERVIEW

2M Python is a low profile EMI/RFI plug and backshell combo. This innovative combination reduces space requirements without compromising on ruggedness or shielding performance. Available in 2M801 Series, 2M804 Series, and 2M805 Series, Python assemblies provide superior low profile cable routing and 2M Micro-miniature connector performance all-in-one.

SPACE SAVINGS

- This plug and backshell combo design saves space, with a minimum height and superior EMI performance.

EASY MAINTENANCE

- The rear removable cover makes it easy to cut wires and remove contacts for maintenance.

SIMPLE ASSEMBLY

- Assembles with crimp or solder cup size 23 contacts.
- Multiple cable entry options available for each connector size (rear opening).

KEY ROTATIONS

- All key rotations are available as well as several connector clockings (rotating main key).

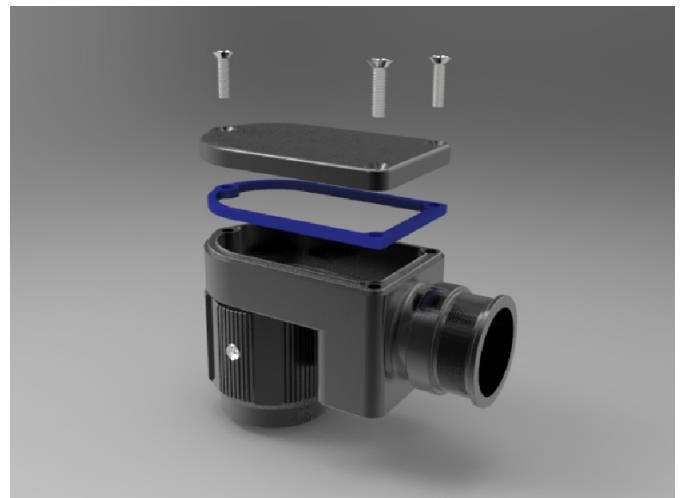

2M MICRO MINIATURE PYTHON

LOW PROFILE EMI/RFI PLUG AND BACKSHELL COMBO

HOW TO ORDER

1. Series	2. Service Class	3. Shell Size & Contact Arrangement	4. Contacts	5. Key Rotation	6. Cable Exit	7. Cable Entry Size
2M805-061-16	MT	8-7	P	A	7	05

1. SERIES

2M801-069-26	2M Dual-Start Plug
2M804-066-06	2M Push-Pull Plug
2M805-061-16	2M Tri-Start Plug

2. SERVICE CLASS

Material	Part #	Description	RoHS
ALUMINUM ALLOY	M	Electroless Nickel	
	NF	Olive Drab Cadmium	
	MT	Durmalon (Ni PTFE)	
	ZN	Olive Drab Zinc Nickel	
	ZNU	Black Zinc Nickel	
STAINLESS STEEL	Z1	Passivated	

3. SHELL SIZE - INSERT ARRANGEMENTS-SEE CHART BELOW

2M801, 2M804	2M805
5-3	
6-4	8-4
6-6	8-6
6-7	8-7
7-10	9-10
8-13	10-13
9-19	11-19
10-26	12-26
13-37	15-37
16-55	18-55
17-85	19-85
21-130	23-130

4. CONTACTS

A	Pin, Solder
B	Socket, Solder
P	Pin, Crimp
S	Socket, Crimp

5. KEYING

Part #	A°	B°
A	150°	210°
B	75°	210°
C	95°	230°
D	140°	275°
E	75°	275°
F	95°	210°

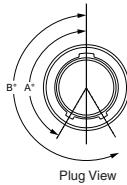

CABLE ENTRY GUIDE

6. CABLE EXIT DIRECTION		7. CABLE ENTRY SIZE	
1	0°	03	0.188
2	45°	04	0.250
3	90°	05	0.313
4	135°	06	0.375
5	180°	07	0.438
6	225°	08	0.500
7	270°	10	0.625
8	315°	12	0.750
		13	0.813
		17	1.063

A:801-069			A:804-066			A:805-061		
Shell Size	Contact Arrangement	Max Entry	Shell Size	Contact Arrangement	Max Entry	Shell Size	Contact Arrangement	Max Entry
5	5-3	03	5	5-3	03	8	8-4, 8-6, 8-7	04
6	6-4, 6-6, 6-7	04	6	6-4, 6-6, 6-7	04	9	9-10	05
7	7-10	05	7	7-10	05	10	10-13	06
8	8-13	06	8	8-13	06	11	11-19	07
9	9-19	07	9	9-19	07	12	12-26	08
10	10-26	08	10	10-26	08	15	15-37	10
13	13-37	10	12	12-37	10	18	18-55	12
16	16-55	12	14	14-55	12	19	19-85	13
17	17-85	13				23	23-130	17
21	21-130	17						