

3U VPX Development Chassis: DK3 “El Sharko”

Supporting VPX and SOSA Aligned Payload Integration

The DK3, “El Sharko” is a flexible **bench top** platform providing the scalability to support rapid development, demonstration and evaluation of 3U VPX and SOSA aligned systems.

It enables shortened design cycles for faster time to deployment. The DK3 allows fast backplane replacement and fast **conversion between air and conduction cooled slot inserts**.

The open frame design includes backplane, power supply, fan cooling and rear transition slots in support of a variety of test functions.

The DK3 comes standard with an 8 slot, 1.2" pitch power and ground **40Gb** backplane to support your development efforts. The DK3 has a balanced 12V / 5V power supply for **mixed power payloads** and a 12V centric power supply is available on request. Both support current and emerging VPX and SOSA aligned module power requirements. The DK3 is part of Amphenol's development solutions supporting VPX system development and the hardware convergence and interoperability initiatives of the US Department of Defense.



Features:

- Quick-conversion air or induction cooled slot inserts
- Standard power and ground 40Gb backplanes
- PCIe Gen3 and 10GbE signal speed capability
- Backplane options to support VPX and SOSA aligned slot profiles
- Open access design and carrying handle
- VITA 66 and 67 apertures for optical and RF I/O
- Adjustable speed high cfm fans
- Rear transition modules slots
- Integrated AC/DC power supply

Benefits:

- Allows testing of air or conduction cooled modules
- Easily swap backplanes to support development progress
- Portability promotes collaboration
- Flexible reconfiguration supports multiple development stages
- Easy test-probe access speeds up development
- Enables single module or application level testing



BACKPLANES

The DK3, "El Sharko" includes as standard an 8 slot 40Gb capable power and ground pass through backplane with 4 x fully populated slots and 4 x slots with VITA 67 full width apertures. Apertures allow installation of VITA 66 / 67 connectors for optical and RF connectivity. Systems can be supplied with or without the required connectors installed.

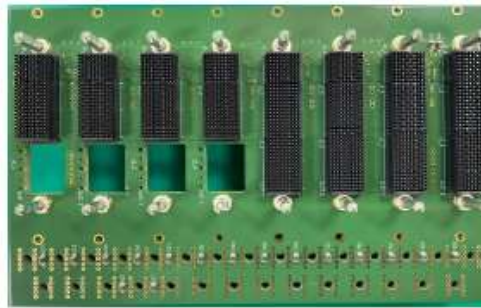

Slots 1-4, VITA 67.3 apertures for full and half width VITA 66 & 67 optical and RF connectivity

Power and ground or pass through backplanes are also referred to as uncommitted backplanes. Uncommitted VPX and SOSA backplanes rely on a slot to slot cabling system to establish the data, control, and expansion planes necessary for integration testing. The backplane in the DK3 includes slot to slot connectivity for power, and ground plus VPX-Standard system signals such as a system reset and reference clocks

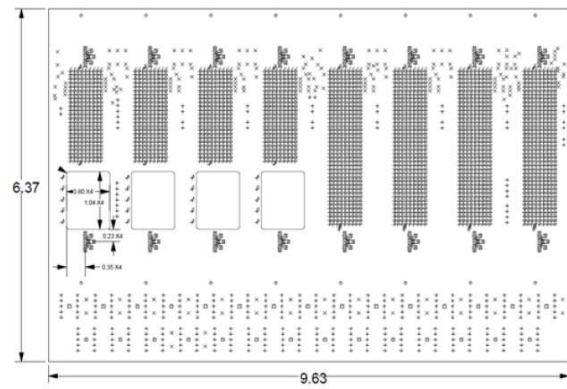
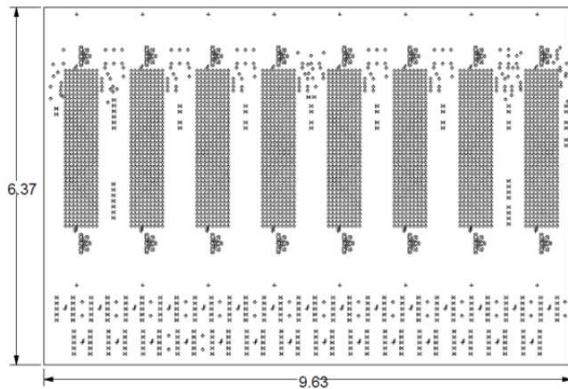

AIR AND CONDUCTION COOLED CONVERSION

The DK3 supports air cooled VITA 48.1 or conduction cooled VITA 48.2 VPX or SOSA aligned plug in cards. Quick conversion air, or conduction cooled card guides, allow slot by slot configuration for mixed payloads. Slot conversion can be completed in minutes to support both card types as needed.

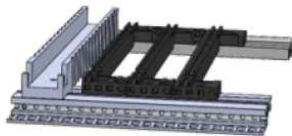

Mixed air and conduction guides



Individual conduction cooled guides

SPECIFICATIONS

Physical

Dimensions including feet and handle: 16.89" (H) x 12.25" (W) x 17.28" (D) 429mm x 311mm x 439mm

Weight: Approximately 39lbs

Power Supplies

Integrated AC-to-DC 1000W power supply
Two available power supply options:

- 1) 12V/5V - 1058W; 12V/450W, 5V/375W, 3.3V/82.5W, -12V/150W
- 2) 12V - 1083W; 12V/600W, 5V/250W, 3.3V/82.5W, -12V/150W

Outputs;
MAIN: +12V, +5V, +3.3V
*AUX: +3.3V, +12V, -12V
**Note: AUX voltages use main voltage rails*

Thermal

Push-pull cooling with 5 upper and 2 lower high cfm fans over the front and RTM areas of the chassis
Heat sensing automatic fan speed plus manual dial override

Conduction cooled guides feature air passthrough cut-outs
Removeable side plates to direct airflow

Environmental

The DK3 is intended for lab use in benign environments

Standards Compliance

The DK3 is intended for use with VITA 48.1 and 48.2 air or conduction cooled 3U VPX and SOSA aligned plug in cards

Controls and I/O

Rear switch for AC ON/OFF, Status indicators: AC, +12V, +5V, +3.3V, -12V

Rear switch for AC ON/OFF

Backplane Options

8 slot power and ground 40Gb backplane, 1.2" pitch, slots 1 - 4 with VITA 67.3 apertures, 1.2" pitch - Consult us regarding fully populated backplanes

Slot Profiles

Power and ground, pass through for profile development using Merteck cabling

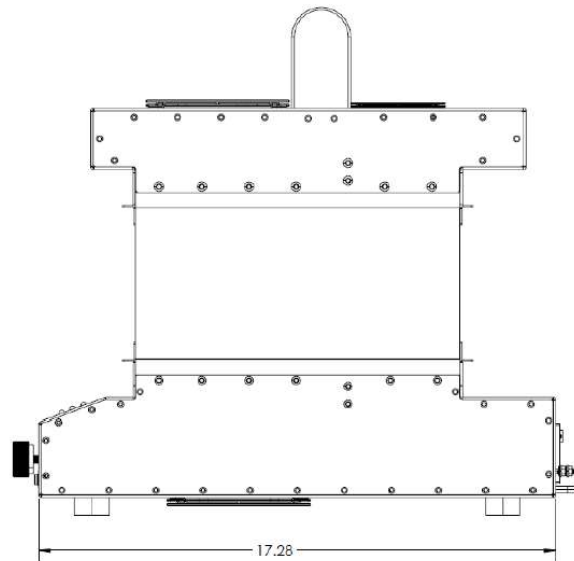
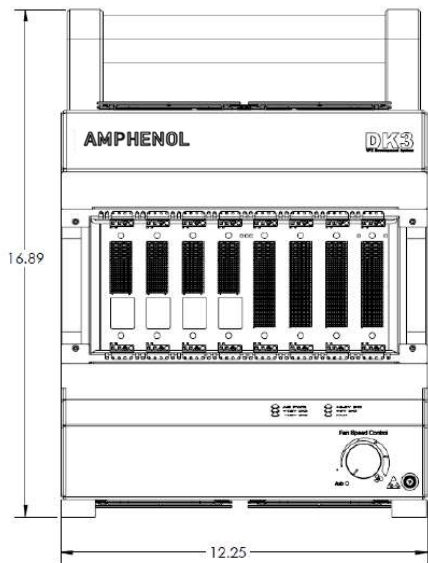

PART NUMBER	DESCRIPTION
CF-020400-604	DK3 development chassis, 8 x 1.2" pitch air-cooled slots, power, and ground pass-thru 40Gb backplane with 4 x VITA67 full width apertures and balanced 12V/5V PSU. Consult Amphenol for 12V centric PSU and fully populated backplane availability
CF-020400-605	Conduction cooled guide accessory kit. Includes top and bottom guides plus mounting hardware