

ETHERNET FIBER TO COPPER SWITCHES AND MEDIA CONVERTERS

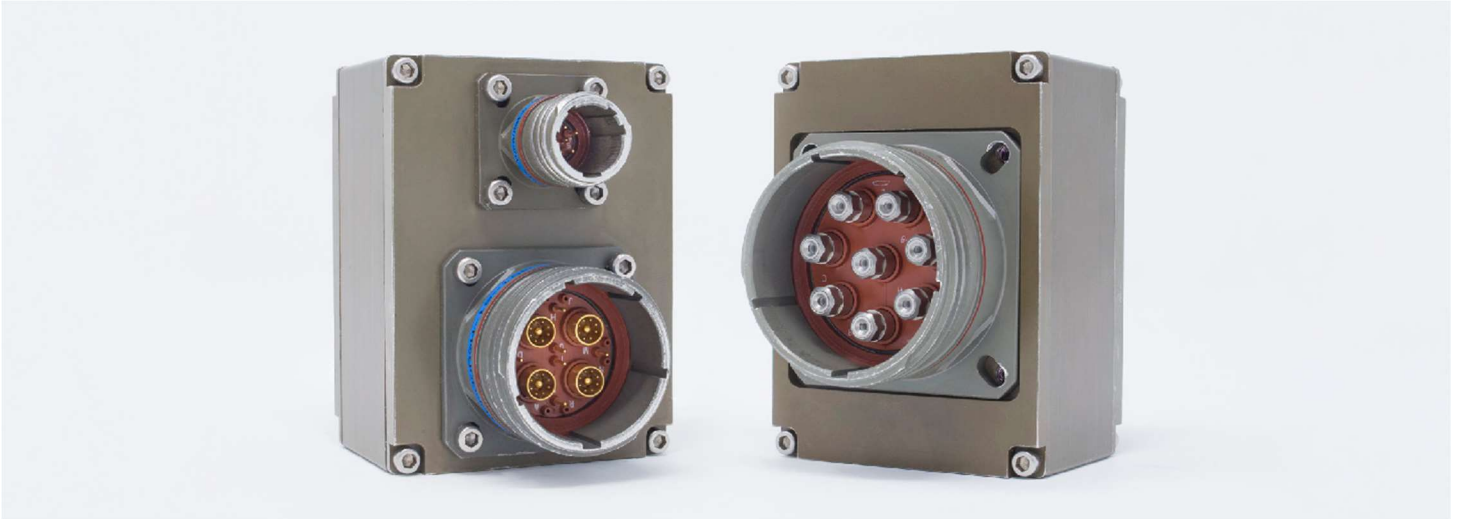

Amphenol Military High Speed is expanding their offering of Ethernet fiber to copper media converters and standalone switches. These products are perfect for a wide variety of harsh environment applications including shipboard, aerospace, ground-based, or industrial systems that need copper and fiber channels.

This fiber to copper media converter supports 10/100/1000BASE-T copper ethernet and a wide variety of fiber optic ethernet including single mode 1GBASE-EX or 1GBASE-LX, multimode 1GBASE-SX or 100BASE-FX, or even 10GBASE-SR. Need something else? Give us a call and we can make it! These converters are fully customizable with plating, keying, clocking, mechanical mounting, modes of fiber, and combinations of copper and fiber ports.

Using the proven MIL-DTL-38999 circular connector to provide a rugged and versatile design, along with an environmentally sealed enclosure creates a robust media converter for any use case. Reliable internal electronics combined with compliant copper contacts provides any system with all the benefits that a world-class connector company like Amphenol can provide!

FEATURES

- IEEE or better specifications supporting the following protocols:
 - 10/100/1G/10GBASE-T
 - 100BASE-FX
 - 1GBASE-SX
 - 1GBASE-EX
 - 1GBASE-LX
 - 10GBASE-SR
- Perfect for routing and switching multiple Ethernet connections into military/aerospace systems
- No need for internal subsystem fiber harnesses, interconnect, or transceivers
- Utilizes copper transceivers and existing interconnect (backplane, harnessing, faceplate) for system fiber connection
- Media conversion at the connector reduces system complexity and cost
- Interfaces for power, diagnostics, and others
- Complete ruggedization for MIL-STD-810 Shock and Vibration
- All benefits of the MIL-DTL-38999 circular connector in a media converter

ORDERING INFORMATION

	COPPER			FIBER				
				SINGLE MODE	MULTIMODE			
	100Mbps 100BASE-T	1Gbps 1GBASE-T	10Gbps 10GBASE-T	1Gbps 1GBASE-EX/LX	100Mbps 100BASE-FX	1Gbps 1GBASE-SX	10Gbps 10GBASE-SX4	10Gbps 10GBASE-SR
CF-020010-56X		2				2		
CF-020010-68X	2				2			
CF-020010-70N		2				2		
CF-020010-71X	2				2			
CF-020010-73X		4				4		
CF-020010-75N		2				2		
CF-020010-78N		2				2		
CF-020010-924			2					2
CF-020010-925							2	2
CF-020011-32X		4				4		
CF-020011-37X		4		4				
CF-020400-39N	2				2			
CF-020400-40N		2				2		
CF-020400-41N		2				2		
CF-020400-51X					2	2		
CF-020400-52X		2		2		3		
CF-020400-56X		8						
CF-020400-57X				2		2		

Part numbers in red are obsolete and should not be designed into new systems. Contact Amphenol for additional solutions.

Part numbers in blue have switching functionality in addition to media conversion.



CONNECTOR INFORMATION

PART NUMBER	J1 CONNECTOR	J1 CONTACT	J2 CONNECTOR	J2 CONTACT	FINISH
CF-020010-924	D38999/20TD35SN	10-497623-185 22D PCB Socket	JSFC15-20MC-4BN	CF-198183-4237	Electroless Nickel
CF-020010-925	CF-509021-16S	CF-198183-4046	CF-509013-04S	CF-198183-4046	O.D. CAD
CF-020011-32X	TVP00RQW-19-18PLC	21-032906-001 Octonet Pin	TVP00RQW-25-08PLC	CF-170900-000 CF-170900-001	O.D. CAD
CF-020011-37X	TVP00RQW-19-52SLC	21-033467-141 Split Pair Quadrax Socket	TVP0RQW-19-18PLC	CF-170900-026	O.D. CAD
CF-020400-39N	TVP00QDZ-19-18SLC	21-033397-221 Quadrax Socket	CF-50Z017-08S	CF-198183-4046	Black Zinc Nickel
CF-020400-40N	TVP00QDZ-19-18SLC	21-033397-221 Quadrax Socket	CF-50Z017-08S	CF-198183-4208	Black Zinc Nickel
CF-020400-41N	TVP00QDZ-19-18SLC	21-033397-221 Quadrax Socket	CF-50Z017-08S	CF-198183-4208	Black Zinc Nickel
CF-020400-51X			TVP00QDT-2508PLC	CF-170900-024 CF-170900-025 CF-170900-001 CF-170900-000	Durmalon
CF-020400-52X	TVP00QDT-19-18P	21-032906-001 Octonet Pin	TVP00GQDT-2508PLC	CF-170900-024 CF-170900-025 CF-170900-001 CF-170900-000	Durmalon
CF-020400-56X	TVP00RQW-19-18P	21-032906-001 Octonet Pin	TVP00RQW-19-18P	21-032906-001 Octonet Pin	O.D. CAD
CF-020400-57X			TVP00QDT-2508PLC	CF-170900-044 CF-170900-045 CF-170900-001 CF-170900-000	Durmalon

To complete part number, first X is key rotation (N, A, B, C, D, E).

Amphenol Ruggedization Design

OVERVIEW:

Amphenol integrated electronic products are designed and manufactured to our Ruggedization guidelines listed below. These guidelines ensure years of reliable operation in harsh environment applications where extreme operating temperatures, shock, vibration, and corrosive atmospheres are regularly experienced. Unless otherwise noted, the parts conform to the below specifications

TEMPERATURE:

- Operating Temperature- Thermal Cycles between -40°C and 85°C while device is operating
- Temperature is measured at chassis housing or card edge
- Storage Temperature- Thermal Cycles between -55°C and 125°C

HUMIDITY:

- Operating Humidity- Humidity cycle between 0-100% non-condensing humidity while device operating
- Storage Humidity- Humidity cycle between 0-100% condensing humidity

SEALING:

- Sealing can be optionally provided at the MIL-DTL-38999 interface with up to 10-5 cc/sec performance

SHOCK AND VIBRATION:

- Sine Vibration - 10g Peak, 5-2,000Hz
 - Based on a sine sweep duration of 10 minutes per axis in each of three mutually perpendicular axes. May be displacement limited from 5 to 44 Hz, depending on specific test.
- Random Vibration - 0.0005 @ 5Hz, 0.1 @ 15 Hz, 0.1 @ 2,000 Hz
 - 60 minutes per axis, in each of three mutually perpendicular axes.
- 40 G Peak Shock Cycle
 - Three hits in each axis, both directions, ½ sine and terminal-peak saw tooth, Total 36 hits.

FLUIDS SUSEPTABILITY:

- MIL-DTL-38999 receptacle interface per EIA-364-10E

ALTITUDE:

- -1,500 to 60,000 ft Altitude Testing w/ Rapid Depressurization

ELECTROMAGNETIC COMPATIBILITY:

- Designed to comply with MIL-STD-461E

PRINTED CIRCUIT BOARD ASSEMBLIES:

- Conformal Coat
- Amphenol performs Conformal Coating to both sides of printed circuit board assemblies using HUSMISEAL IB31 in accordance with IPC-610, Class 3.
- Printed Circuit Board Rigidity
- Amphenol printed circuit boards are fabricated in accordance with IPC-6012, Class 3.
- Printed Circuit Board Fabrication
- Amphenol printed circuit boards acceptance criteria is in accordance with IPC-610, Class 3.

RELIABILITY PREDICTIONS (MTBF):

Amphenol can perform Mean Time Between Failure (MTBF) reliability analysis in full compliance with MIL-HDBK-217F-1 Parts Count Prediction and MIL-HDBK-217F-1 Parts Stress Analysis Prediction. We can also perform reliability analyses in full compliance of ANSI/VITA 51.1 if it is required or preferred over the later method

MECHANICAL SPECIFICATION

CF-020010-73X, CF-020011-32X, CF-020400-52X

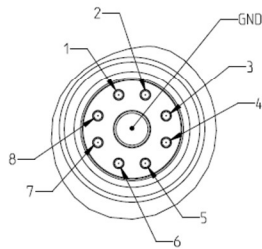
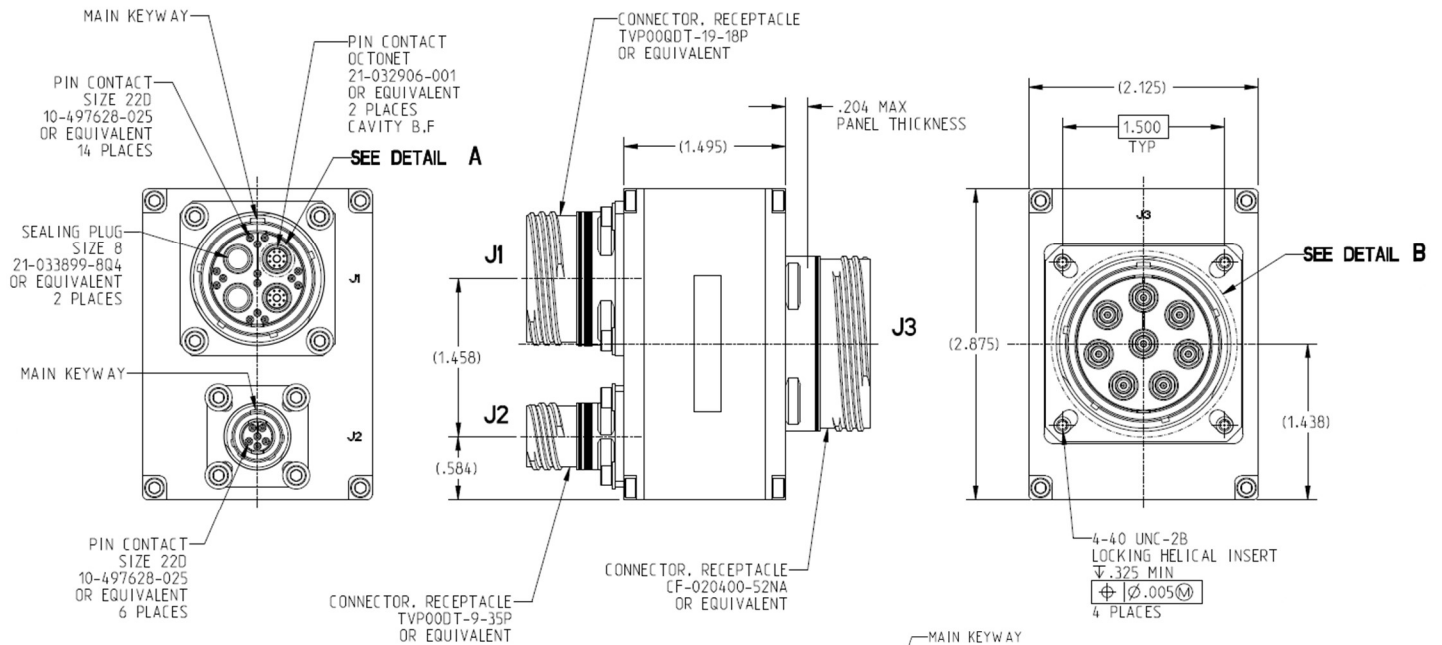

DETAIL A
J1 CONNECTOR FRONT VIEW
OCTONET PIN POSITION
SCALE 8.000

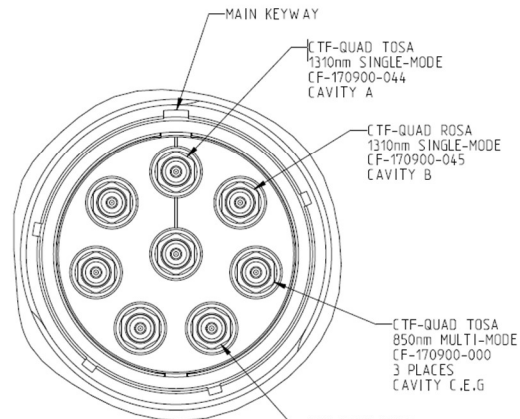

DETAIL B
J3 CONNECTOR
SCALE 3.000

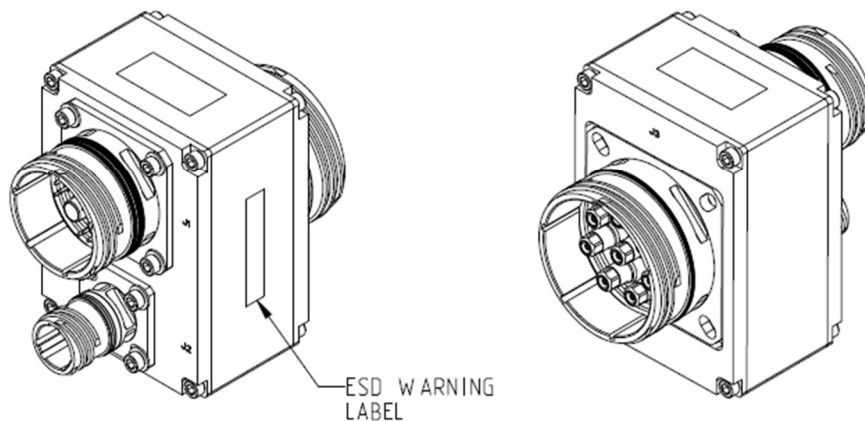

CF-020010-37X, CF-020400-56X

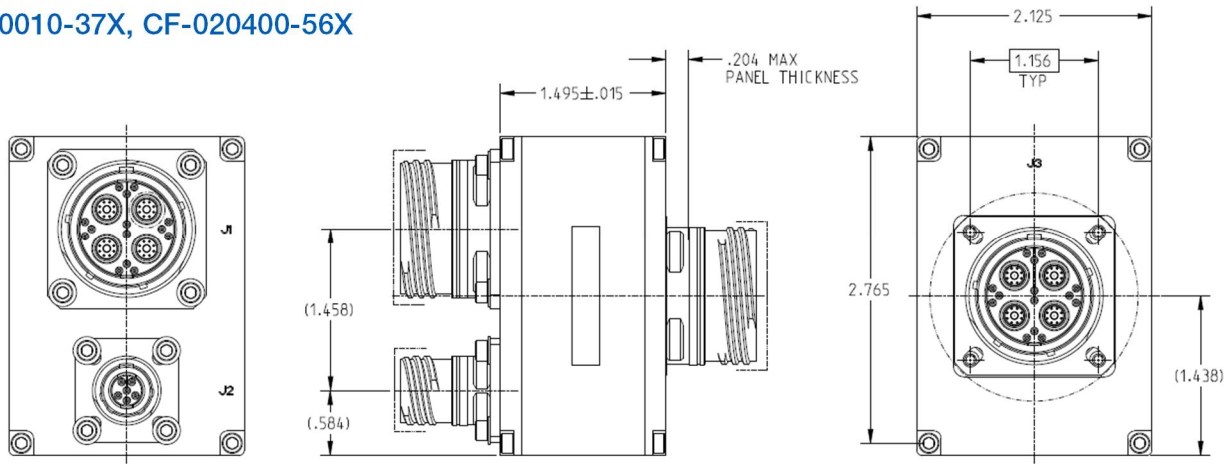

CF-020010-37X Pinout

J1 CONNECTOR		J2 CONNECTOR		J3 CONNECTOR	
ID	DESCRIPTION	ID	DESCRIPTION	ID	DESCRIPTION
1	CHASSIS_GND	A1	CH1_AC COUPLED CML+	B	FO_TX1
2	CHASSIS_GND	A4	CH1_AC COUPLED CML-	F	FO_TX2
3	CHASSIS_GND	A3	CH2_AC COUPLED CML+	K	FO_TX3
4	CHASSIS_GND	A2	CH2_AC COUPLED CML-	P	FO_TX4
5	28VIN	B1	CH3_AC COUPLED CML+		
6	GND	B4	CH3_AC COUPLED CML-		
		B3	CH4_AC COUPLED CML+		
		B2	CH4_AC COUPLED CML-		

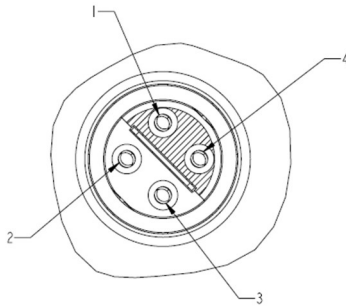

DETAIL A
J2 CONNECTOR FRONT VIEW
SPLIT-PAIR QUAD

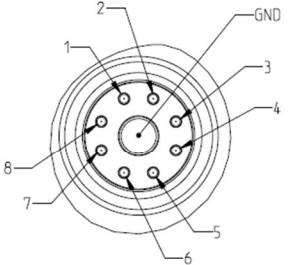

DETAIL A
OCTONET PIN POSITION
SCALE 8.000

CF-020400-56X Pinout

J1 CONNECTOR		J2 CONNECTOR		J3 CONNECTOR	
ID	DESCRIPTION	ID	DESCRIPTION	ID	DESCRIPTION
B-1	CH1_A_1GBASE-T_P	1	CHASSIS_GND	B-1	CH5_A_1GBASE-T_P
B-2	CH1_A_1GBASE-T_N	2	CHASSIS_GND	B-2	CH5_A_1GBASE-T_N
B-3	CH1_B_1GBASE-T_P	3	CHASSIS_GND	B-3	CH5_B_1GBASE-T_P
B-4	CH1_B_1GBASE-T_N	4	CHASSIS_GND	B-4	CH5_B_1GBASE-T_N
B-5	CH1_C_1GBASE-T_P	5	28VDC	B-5	CH5_C_1GBASE-T_P
B-6	CH1_C_1GBASE-T_N	6	28VDC_RTN	B-6	CH5_C_1GBASE-T_N
B-7	CH1_D_1GBASE-T_P			B-7	CH5_D_1GBASE-T_P
B-8	CH1_D_1GBASE-T_N			B-8	CH5_D_1GBASE-T_N
B-GND	GND			B-GND	GND
F-1	CH2_A_1GBASE-T_P			F-1	CH6_A_1GBASE-T_P
F-2	CH2_A_1GBASE-T_N			F-2	CH6_A_1GBASE-T_N
F-3	CH2_B_1GBASE-T_P			F-3	CH6_B_1GBASE-T_P
F-4	CH2_B_1GBASE-T_N			F-4	CH6_B_1GBASE-T_N
F-5	CH2_C_1GBASE-T_P			F-5	CH6_C_1GBASE-T_P
F-6	CH2_C_1GBASE-T_N			F-6	CH6_C_1GBASE-T_N
F-7	CH2_D_1GBASE-T_P			F-7	CH6_D_1GBASE-T_P
F-8	CH2_D_1GBASE-T_N			F-8	CH6_D_1GBASE-T_N
F-GND	GND			F-GND	GND
K-1	CH3_A_1GBASE-T_P			K-1	CH7_A_1GBASE-T_P
K-2	CH3_A_1GBASE-T_N			K-2	CH7_A_1GBASE-T_N
K-3	CH3_B_1GBASE-T_P			K-3	CH7_B_1GBASE-T_P
K-4	CH3_B_1GBASE-T_N			K-4	CH7_B_1GBASE-T_N
K-5	CH3_C_1GBASE-T_P			K-5	CH7_C_1GBASE-T_P
K-6	CH3_C_1GBASE-T_N			K-6	CH7_C_1GBASE-T_N
K-7	CH3_D_1GBASE-T_P			K-7	CH7_D_1GBASE-T_P
K-8	CH3_D_1GBASE-T_N			K-8	CH7_D_1GBASE-T_N
K-GND	GND			K-GND	GND
P-1	CH4_A_1GBASE-T_P			P-1	CH8_A_1GBASE-T_P
P-2	CH4_A_1GBASE-T_N			P-2	CH8_A_1GBASE-T_N
P-3	CH4_B_1GBASE-T_P			P-3	CH8_B_1GBASE-T_P
P-4	CH4_B_1GBASE-T_N			P-4	CH8_B_1GBASE-T_N
P-5	CH4_C_1GBASE-T_P			P-5	CH8_C_1GBASE-T_P
P-6	CH4_C_1GBASE-T_N			P-6	CH8_C_1GBASE-T_N
P-7	CH4_D_1GBASE-T_P			P-7	CH8_D_1GBASE-T_P
P-8	CH4_D_1GBASE-T_N			P-8	CH8_D_1GBASE-T_N
P-GND	GND			P-GND	GND

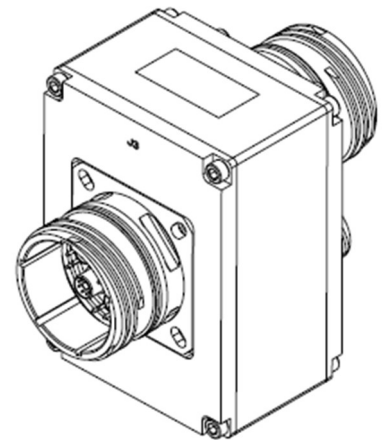
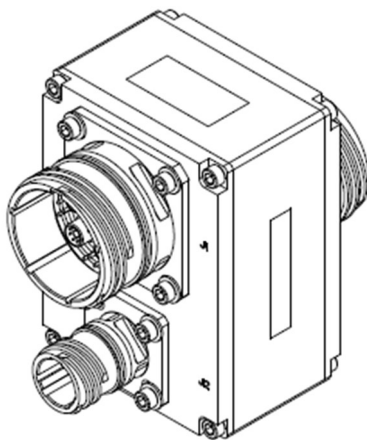

CF-020400-39N, CF-020400-40N, CF-020400-41N

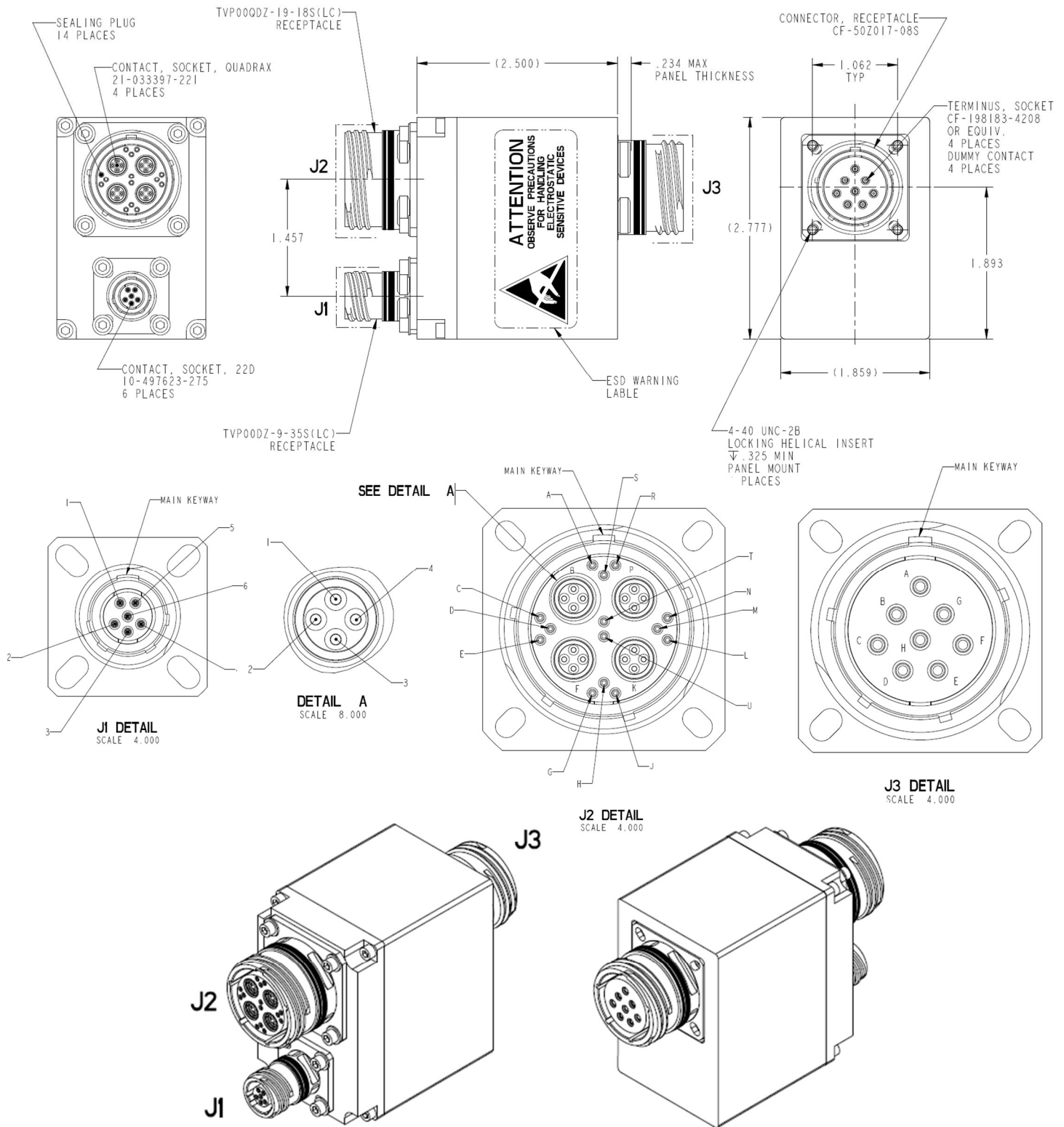

CF-020400-51X, CF-020400-57X

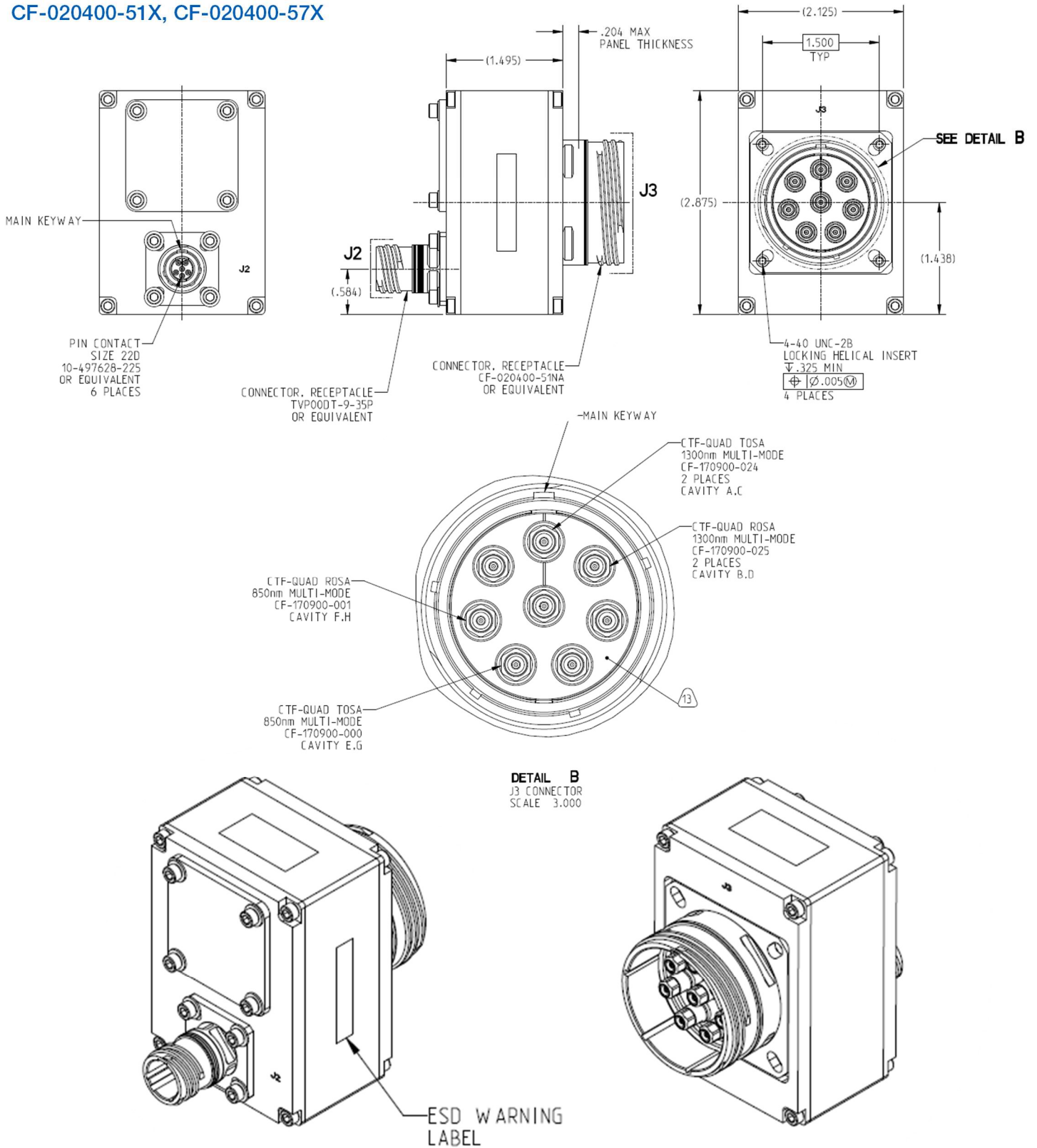

CF-020010-924

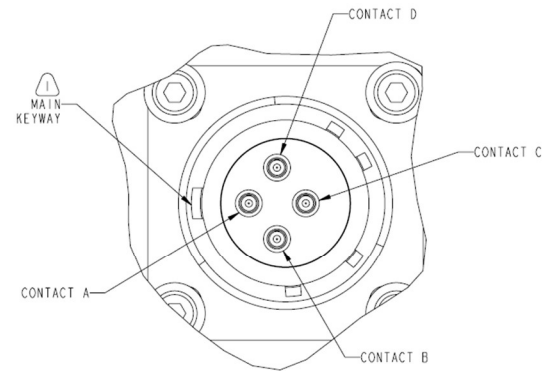
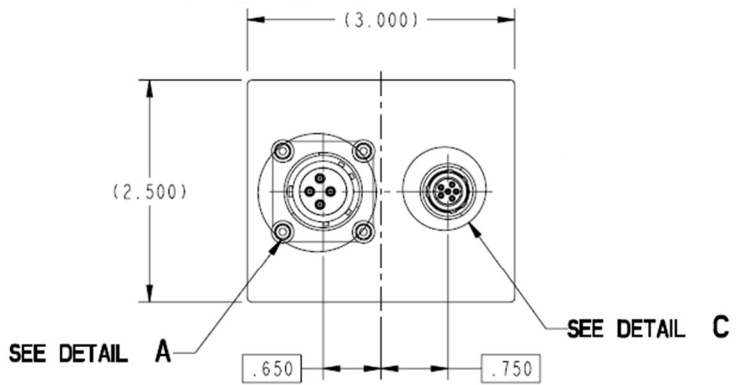

DETAIL A
(INSERT ARRANGEMENT L-21813-4)
SCALE 4.000

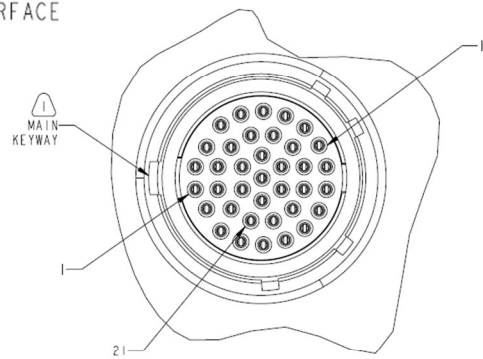
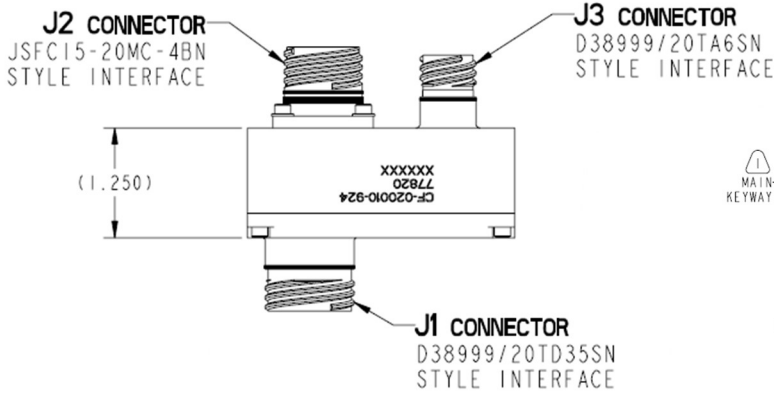

DETAIL B
(INSERT ARRANGEMENT L-21815-35)
SCALE 4.000

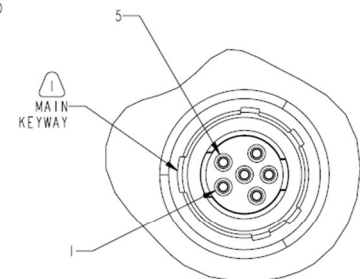
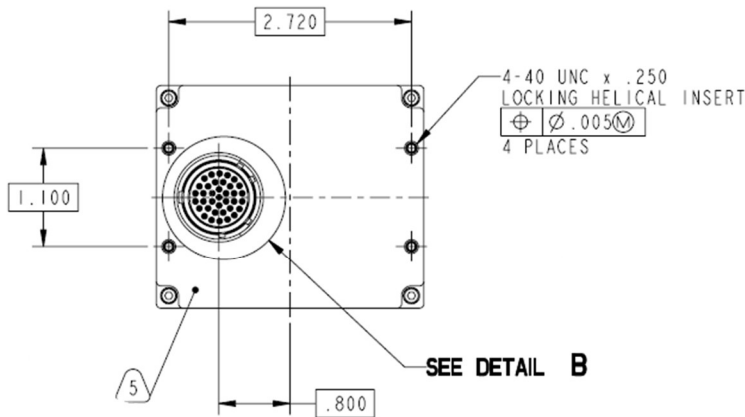

DETAIL C
(INSERT ARRANGEMENT L-21809-6)
SCALE 4.000

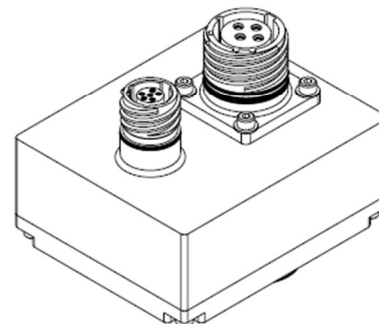
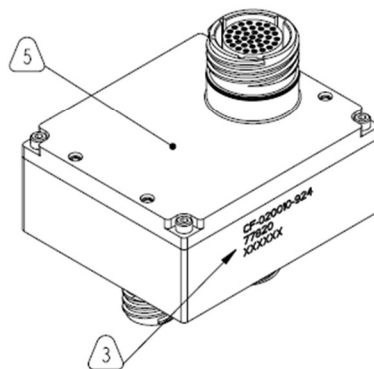

CF-020010-925

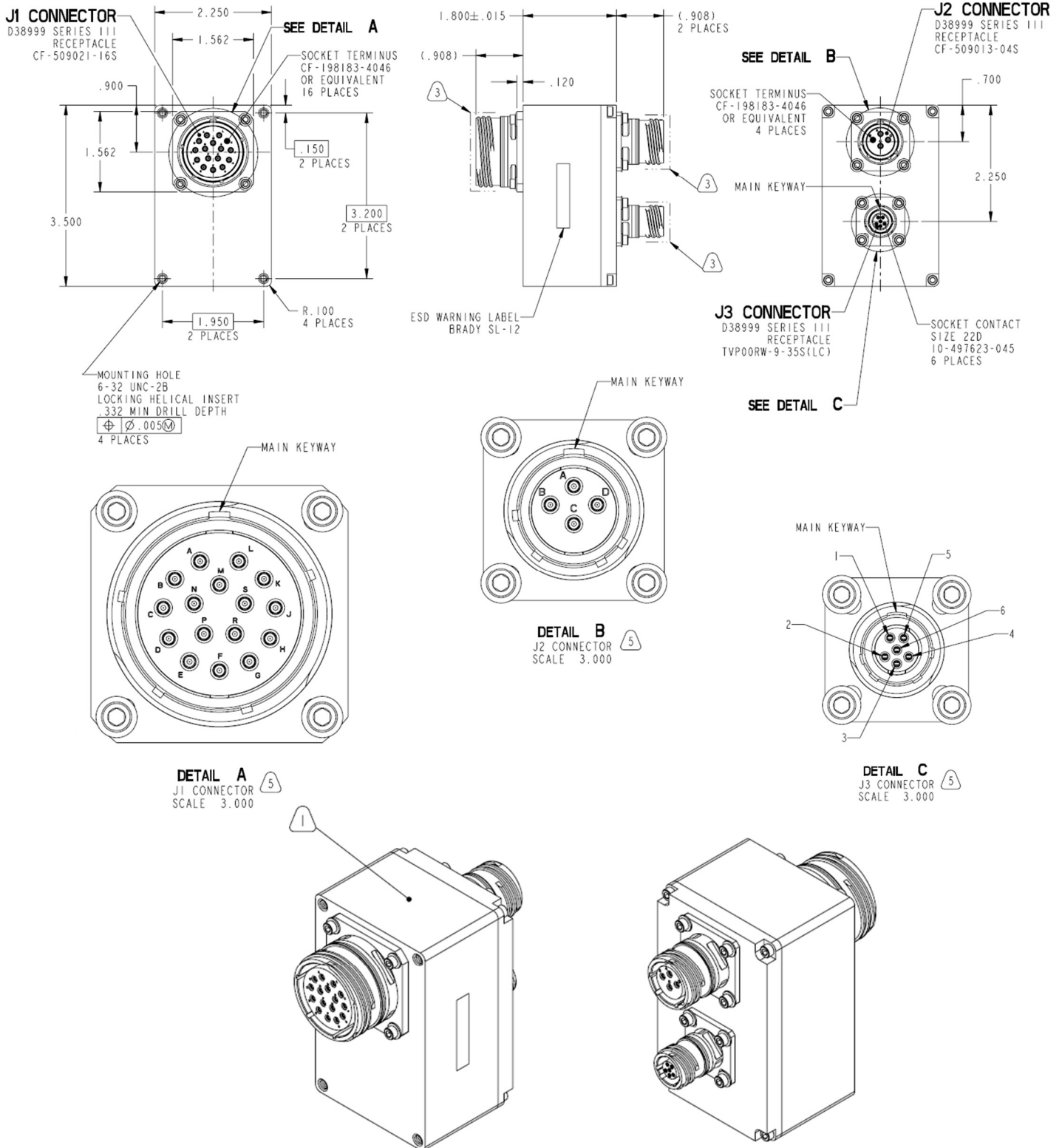

Notice: Specifications are subject to change without notice. Contact your nearest Amphenol Corporation Sales Office for the latest specifications. All statements, information and data given herein are believed to be accurate and reliable but are presented without guarantee, warranty, or responsibility of any kind, expressed or implied. Statements or suggestions concerning possible use of our products are made without representation or warranty that any such use is free of patent infringement and are not recommendations to infringe any patent. The user should assume that all safety measures are indicated or that other measures may not be required. Specifications are typical and may not apply to all connectors. AMPHENOL is a registered trademark of Amphenol Corporation. ©2023 Amphenol Corporation REV: 2023



40-60 Delaware Avenue
Sidney, NY 13838
amphenol-aerospace.com | amphenolmao.com