

M169 SERIES

SINGLE-OUTPUT, UP TO 1KW AC/DC POWER SUPPLY

The M169 is a series of mechanically robust, base plate cooled, high performance, 1kW single output AC to DC power supplies, for Navy shipboard, Airborne, and ground applications.

The M169 converts 85 V_{AC} -265 V_{AC} /50-60Hz or 85 V_{AC} -150 V_{AC} /400Hz, to a well-regulated, filtered and protected DC Output.



M169 Series– AC/DC Power Supply

THE MAIN FEATURES OF THE M169 ARE:

- AC/DC Single output power supply up to 1kW
- 85V_{AC}-265V_{AC}/50-60Hz or 85V_{AC}-150V_{AC}/ 400Hz Standard Input version, single-phase
- For extended input version - **Please contact factory for more details**
- High efficiency
- Wide input range
- High power factor
- Input / Output isolation
- Remote sense compensation
- Remote Inhibit (On/Off)
- External sync. capability
- EMI filters included
- Inrush Current Limiter
- Non-latching protections:
 - Overload/Short-circuit
 - Output Overvoltage
 - Over Temperature
 - Input Undervoltage Lockout

M169 Series– AC/DC Power Supply

Standard Models List (for other voltages – consult factory)

Part number	Input		Output		Special features
	Voltage range	Frequency	Voltage	Current	
M169100	85-265VAC/Single phase	50/60/400Hz	5 V _{DC}	70 A	
M169101	85-265VAC/Single phase	50/60/400Hz	12 V _{DC}	70 A	
M169102	85-265VAC/Single phase	50/60/400Hz	24 V _{DC}	42 A	
M169103	85-265VAC/Single phase	50/60/400Hz	28 V _{DC}	36 A	
M169104	85-265VAC/Single phase	50/60/400Hz	48 V _{DC}	21 A	
M169105	85-265VAC/Single phase	50/60/400Hz	270 V _{DC}	4 A	
M169106	85-265VAC/Single phase	50/60/400Hz	28 V _{DC}	36 A	Parallel operation via output voltage droop. Voltage regulation is ±2%..
M169107	85-265VAC/Single phase	50/60/400Hz	48 V _{DC}	21 A	Parallel operation via output voltage droop. Voltage regulation is ±2%..
M169108	85-265VAC/Single phase	50/60/400Hz	24 V _{DC}	42 A	Parallel operation via output voltage droop. Voltage regulation is ±2%..

- Additional standard configurations available. **Contact factory for more details.**
- All of our products can be configured to comply with EU REACH regulations. **Contact factory for more details.**

M169 Series– AC/DC Power Supply

SPECIFICATIONS:

AC Input	Voltage Range	Option 1: 85 V _{AC} -265 V _{AC} /50 Hz - 60 Hz / Single-phase Option 2: 85 V _{AC} -150 V _{AC} /400 Hz / Single-phase For extended input version - Please contact factory for more details
	Isolation	1 000 V _{DC} Input to Output 1 000 V _{DC} Input and Case
	Spikes	Optional to withstand 1000 V spikes IAW MIL-STD-1399-300B. please consult factory
DC Output	Rating	See table on page 8
	Voltage Regulation	Up to ±1% (no load to full load, –40 °C to +85 °C and over normal input voltage range).
	Remote Sense	The SENSE is used to achieve accurate load regulations at load terminals (this is done by connecting the pins directly to the load's terminals). For output voltage above 8V, the use of remote sense has a max limit of 0.25V voltage dropout between converter's output and load terminals. For output voltage below 8V, the use of remote sense has a max limit of 0.5V voltage dropout between converter's output and load terminals. When not used connect SENSE to OUT and SENSE RTN to OUT RTN.
	Ripple and Noise	(max. 1%) measured at load across 1 μF and 0.1 μF ceramic capacitors.
	Isolation	200 V _{DC} Output and Case. (At M169-105 it is 500V _{DC})
	Current Limit & Overload	Output turns off and on periodically (hiccup) until fault is condition removed. Protection threshold set at 120% ± 10% of maximum current
	Efficiency	Up to 85-87% - typical (nominal input voltage, full load, room temperature)
	Overvoltage Protection	Active Over-Voltage Protection Internal control shuts output down if voltage exceeds 110% ± 5% of nominal. Passive Over-Voltage Protection A transorb, rated to 120% ± 10% of nominal voltage, is placed across the output
	Over Temp. Protection	Unit shuts down if baseplate temperature exceeds 100 ± 5 °C. Automatic recovery upon cooldown to below 90 ± 5 °C.

M169 Series– AC/DC Power Supply

Specifications (Cont.):

Control & Indication	ON/OFF input	<p>The INHIBIT IN signal is used to turn the power supply ON and OFF.</p> <p>TTL “1” or OPEN – will turn on the power supply. (For normal operation leave the signal not connected.)</p> <p>TTL “0” – will turn off the power supply.</p> <p>Ground reference for the INHIBIT IN signal is SIGNAL RTN (pin #1).</p> <p>Optional on/off ENABLE IN signal - Please consult factory:</p> <p>TTL “0” or OPEN – will turn on the power supply. (For normal operation leave the signal not connected.)</p> <p>TTL “1” – will turn off the power supply.</p> <p>Ground reference for the ENABLE IN signal is SIGNAL RTN (pin #1).</p>
	INHIBIT OUT	<p>Used when connecting two units or more in parallel.</p> <p>Connect this signal to the INHIBIT IN pin of the slave unit (see diagram below). This signal synchronizes the shutdown and startup of the units.</p>
	SYNC IN	<p>The SYNC IN signal is used to allow the power supply frequency to sync with the system frequency. The system frequency should be 250 kHz ± 10 kHz.</p> <p>When not connected the power supply will work at 250 kHz ± 10 kHz.</p>
	SYNC OUT	<p>The SYNC OUT signal is used to sync the system with the power supply frequency.</p>
	SIGNAL RTN	<p>The SIGNAL RTN is a floated ground.</p> <p>This pin is used as ground return for SYNC IN, SYNC OUT, INHIBIT IN and INHIBIT OUT signals.</p>
Environment Designed to meet MIL-STD-810F	Temperature	<p>Methods 501.4 & 502.4</p> <p>Operating: –40 °C to +85 °C (at baseplate)</p> <p>Storage: –55 °C to +125 °C (ambient)</p>
	Humidity	<p>Method 507.4</p> <p>Procedure I</p> <p>Up to 95% RH</p>
	Salt-fog	<p>Method 509.5</p>
	Altitude	<p>Method 500.4</p> <p>Procedures I – up to 70,000 ft. (non-operational)</p> <p>Procedure II – up to 40,000 ft. (operational)</p>

M169 Series– AC/DC Power Supply

	<i>Mechanical Shock</i>	Method 516.5 Procedure I 30 g, 11 ms terminal peak saw-tooth
	<i>Vibration</i>	Method 514.5 Procedure I Category 24 - General minimum integrity exposure
	<i>Fungus</i>	Does not support fungus growth, in accordance with the guidelines of MIL-STD-454, Requirement 4
EMI	<i>MIL-STD-461F</i>	Designed to meet* MIL-STD-461F CE101, CE102, CS101, CS114, CS115, CS116, RE101, RS101, RS103
Reliability	150,000 hours, calculated per MIL-STD-217F Notice 2 at +85 °C baseplate, Ground Fixed environment.	
Form factor	5.51" wide, 1.50" high and 9.84" deep. For detailed dimensions and tolerances see Drawing: M169001	
Weight	1.92kg (4.25lbr)	
Connectors	See Page 9-11	

*Compliance achieved with shielded harness and static resistive load.

M169 Series– AC/DC Power Supply

PIN ASSIGNMENT: J1 - INPUT CONNECTOR

Connector type: M24308/24-38F or eq.

Mates with: M24308/2-2F or eq.

Pin #	Function	P
1	PHASE	~
2	PHASE	~
3	PHASE	~
4	N.C.	
5	NEUTRAL	0

Pin #	Function	P
6	NEUTRAL	0
7	N.C.	
8	CHASSIS	
9	PHASE	~
10	PHASE	~

Pin #	Function	P
11	N.C.	
12	NEUTRAL	0
13	NEUTRAL	0
14	NEUTRAL	0
15	N.C.	

Note: All pins with identical function/designation should be connected together for optimal performance.

CHASSIS Note: Chassis PIN

This pin is connected to the converter's chassis.

M169 Series– AC/DC Power Supply

PIN ASSIGNMENT: J2 - OUTPUT CONNECTOR

Connector type: M24308/23-41F or eq.

Mates with: M24308/4-5F or eq.

Pin #	Function	P	Pin #	Function	P	Pin #	Function	P
1	SIGNAL RTN	–	18	INHIBIT OUT	+	35	INHIBIT IN	+
2	SYNC OUT	+	19	SENSE RTN	–	36	N.C.	
3	SENSE	+	20	OUT	+	37	OUT	+
4	OUT	+	21	OUT	+	38	OUT	+
5	OUT	+	22	OUT	+	39	OUT	+
6	OUT	+	23	OUT	+	40	OUT	+
7	OUT	+	24	OUT	+	41	OUT	+
8	OUT	+	25	OUT	+	42	OUT	+
9	OUT	+	26	OUT	+	43	OUT	+
10	OUT	+	27	OUT RTN	–	44	OUT RTN	–
11	OUT RTN	–	28	OUT RTN	–	45	OUT RTN	–
12	OUT RTN	–	29	OUT RTN	–	46	OUT RTN	–
13	OUT RTN	–	30	OUT RTN	–	47	OUT RTN	–
14	OUT RTN	–	31	OUT RTN	–	48	OUT RTN	–
15	OUT RTN	–	32	OUT RTN	–	49	OUT RTN	–
16	OUT RTN	–	33	OUT RTN	–	50	OUT RTN	–
17	OUT RTN	–	34	SYNC IN	+			

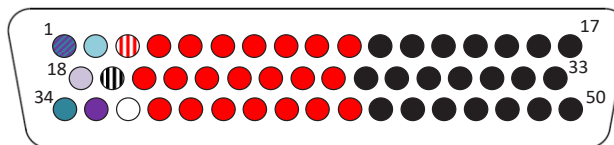

Note: All pins with identical function/designation should be connected together for optimal performance.

CHASSIS Note: Chassis PIN

This pin is connected to the converter's chassis.

M169 Series– AC/DC Power Supply

HV option: High voltage version (100 to 300 VDC)

Pin #	Function	P	Pin #	Function	P	Pin #	Function	P
1	SIGNAL RTN	-	18	INHIBIT OUT	+	35	INHIBIT IN	+
2	SYNC OUT	+	19	N.C.	-	36	N.C.	
3	N.C.	+	20	OUT	+	37	OUT	+
4	OUT	+	21	OUT	+	38	OUT	+
5	OUT	+	22	OUT	+	39	OUT	+
6	OUT	+	23	OUT	+	40	OUT	+
7	OUT	+	24	OUT	+	41	OUT	+
8	OUT	+	25	OUT	+	42	OUT	+
9	OUT	+	26	OUT	+	43	OUT	+
10	OUT	+	27	OUT RTN	-	44	OUT RTN	-
11	OUT RTN	-	28	OUT RTN	-	45	OUT RTN	-
12	OUT RTN	-	29	OUT RTN	-	46	OUT RTN	-
13	OUT RTN	-	30	OUT RTN	-	47	OUT RTN	-
14	OUT RTN	-	31	OUT RTN	-	48	OUT RTN	-
15	OUT RTN	-	32	OUT RTN	-	49	OUT RTN	-
16	OUT RTN	-	33	OUT RTN	-	50	OUT RTN	-
17	OUT RTN	-	34	SYNC IN	+			

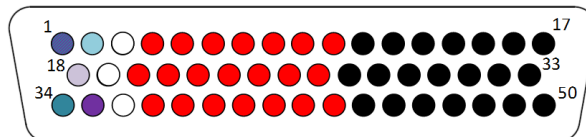

Note: All pins with identical function/designation should be connected together for optimal performance.

CHASSIS Note: Chassis PIN

This pin is connected to the converter's chassis.

M169 Series— AC/DC Power Supply

OUTLINE DRAWING:

For detailed dimensions and tolerances see Drawing: M169001

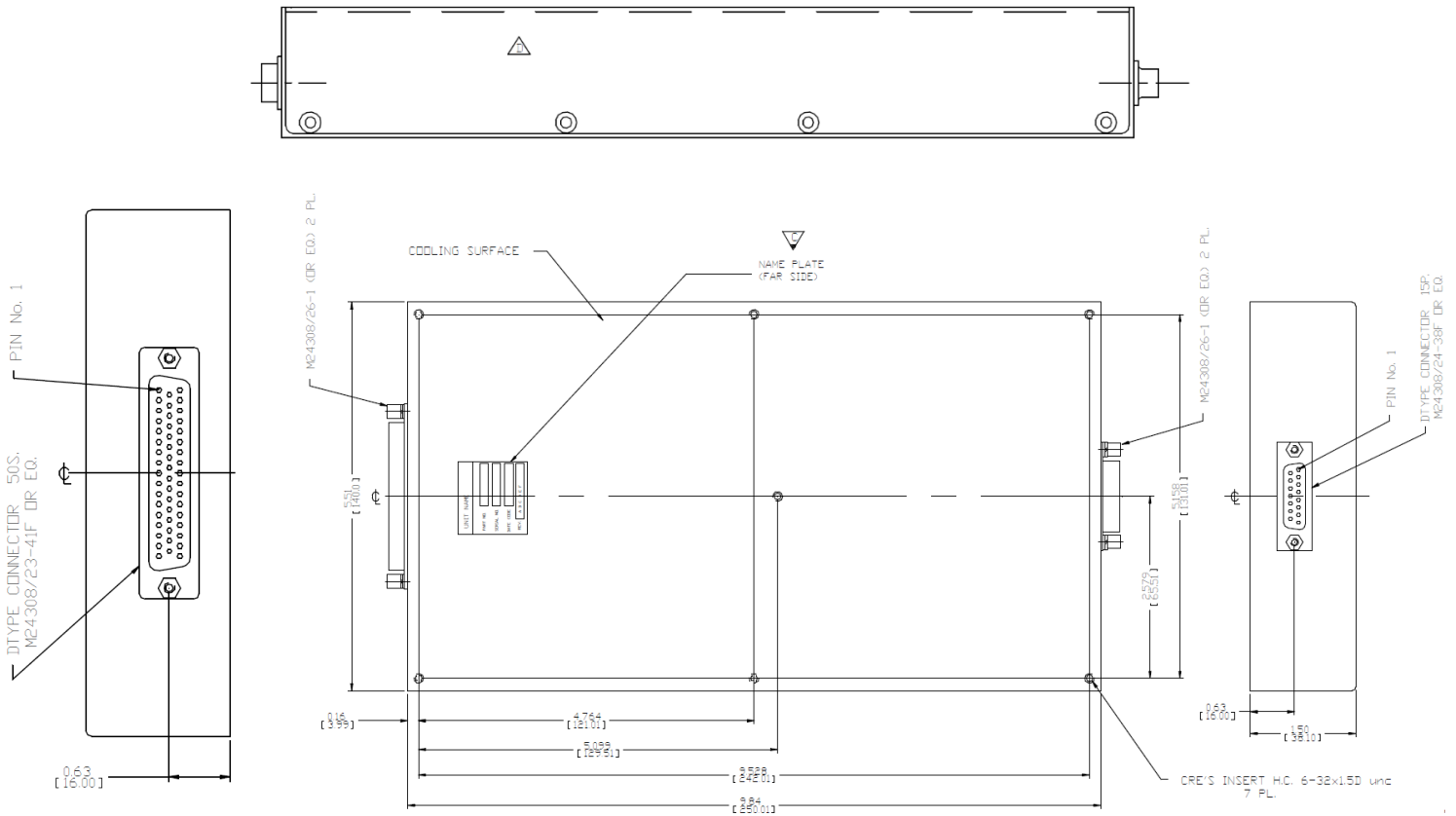

HEAT DISSIPATION SURFACE:

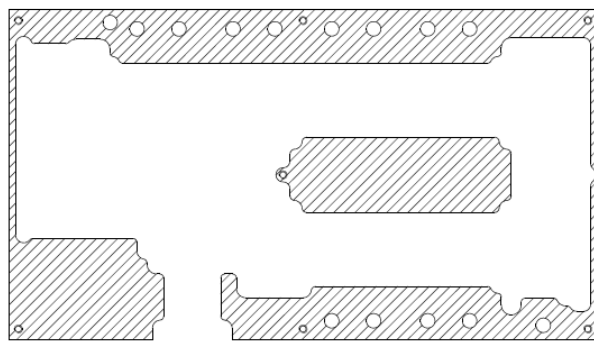

Dissipation Area
21.08 in²
(13,600 mm²)

Notes

1. Dimensions are in inches [mm]
2. Tolerance is:
.XX ± .02 in
.XXX ± .01 in
3. Weight: 4.25 lbs [1922 g]

Note: Specifications are subject to change without prior notice by the manufacturer.