

### M1982 SERIES

*AC/DC POWER SUPPLY*



#### PRODUCT HIGHLIGHTS

- HIGH DENSITY
- HIGH POWER FACTOR
- SINGLE OUTPUT
- AC/DC POWER SUPPLY
- UP TO 300 W
- OPTIONAL 10J HOLDUP

#### Description

The M1982 military power supply is a rugged AC to DC converter. It accepts an AC input range from 85 to 265VAC, 50/60/400Hz and provides a single DC output from 3.3V to 48V, up to 300W, with custom outputs available. Designed to meet military standards MIL-STD-704, MIL-STD-1399, MIL-STD-810, MIL-STD-461.

### Applications

Military (Airborne, ground-fix, shipboard), Ruggedized, Telecom, Industrial

### Special Features

- Miniature size
- High efficiency
- Wide input range
- High power factor (0.99)
- Input / Output isolation
- Inrush Current Limiter
- External Inhibit (On/Off)
- Fixed switching freq. (250 kHz)
- Externally synchronizable
- EMI filters included
- Remote sense compensation
- Indefinite short circuit protection with auto-recovery
- Over-voltage shutdown with auto-recovery
- Over temperature shutdown with auto-recovery

### Electrical Specifications

#### AC Input

85 to 265 V<sub>AC</sub>, 50/60/400 Hz  
single-phase  
IAW MIL-STD-704A<sup>†</sup>  
(115 V<sub>rms</sub> / 400 Hz)  
& MIL-STD-1399-300B Type I<sup>‡</sup>  
(115 V<sub>rms</sub> / 60 Hz)

#### Line/Load regulation

Less than 1% (no load to full load, -40°C to +85°C)

#### Ripple and Noise

100 - 150 mV<sub>p-p</sub>, typical (max 1%) without external capacitance.

#### DC Output

Voltage range: 3.3 to 48 V<sub>DC</sub>  
Current range: 0 to 20 A  
Power range: 0 to 300 W

#### Efficiency

86% Typical (115 V<sub>rms</sub> input)  
88% Typical (230 V<sub>rms</sub> input)  
(Both at 28 V<sub>DC</sub> output, full load, room temperature)

#### Load Transient Response

For 28 V<sub>DC</sub> output, current change from 50% - 100% results in less than 0.5V change and settling within 200 - 300 μs

#### Isolation

Input to Output: 1000 V<sub>DC</sub>  
Input to Case: 1000 V<sub>DC</sub>  
Output to Case: 200 V<sub>DC</sub>

#### EMC

Designed to meet \* MIL-STD-461F: CE101, CE102, CS101, CS114, CS115, CS116, RE101, RE102, RS101, RS103

#### Turn on Transient

No output voltage overshoot during power on.

<sup>†</sup> Standard models do not maintain output regulated during transfer operation and/or during normal under-voltage transients. If such features are required, please consult factory.

<sup>‡</sup> Standard models do not maintain output regulated during automatic bus transfer operation. If such a feature is required, please consult factory.

\* Compliance achieved with shielded harness and static resistive load.

## M1982 AC/DC POWER SUPPLY

### Protections \*

#### Input

- **Inrush Current Limiter**  
Peak value of up to 5 times maximum input current for less than 50  $\mu$ s.
- **Under Voltage Lock-Out**  
Unit protects itself (no damage) below 75 V<sub>AC</sub> and turn off.

#### Output

- **Active Over Voltage Protection**  
10%  $\pm$  2% above nominal voltage.
- **Passive Over Voltage Protection**  
Transorb at output selected 20%  $\pm$  5% above nominal voltage.
- **Over Load / Short Circuit**  
10 - 30% above maximum current, indefinitely (Hiccup).

#### General

- **Over Temperature Protection**  
Shutdown at base plate temp. above +105  $^{\circ}$ C  $\pm$  5  $^{\circ}$ C  
Automatic recovery at base plate temp. below +95  $^{\circ}$ C  $\pm$  5  $^{\circ}$ C

### Environmental Conditions

Designed to Meet MIL-STD-810F

#### Temperature

Methods 501.4 & 502.4  
Operating: -40 $^{\circ}$ C to +85 $^{\circ}$ C (at baseplate)  
Storage: -55 $^{\circ}$ C to +125 $^{\circ}$ C (ambient)

#### Altitude

Method 500.4  
Procedures I – Storage/Air transport:  
up to 70,000 ft. (non-operational)  
Procedure II – Operation/Air Carriage:  
up to 40,000 ft. (operational)

#### Humidity

Method 507.4  
Up to 95% RH

#### Vibration

Method 514.5  
Procedure I, Category 24  
General minimum integrity exposure  
IAW Figure 514.5C-17  
1 hour per axis.

#### Shock

Method 516.5  
Procedure I  
20 g / 11 ms terminal peak sawtooth shock pulse

#### Salt Fog

Method 509.4

### Reliability

150,000 hours, calculated IAW MIL-HDBK-217F Notice 2 at +85 $^{\circ}$ C baseplate, Ground fixed conditions.

\* Thresholds and protections can be modified / removed – please consult factory

### Efficiency Plot

M1982-103 variant (24V output):

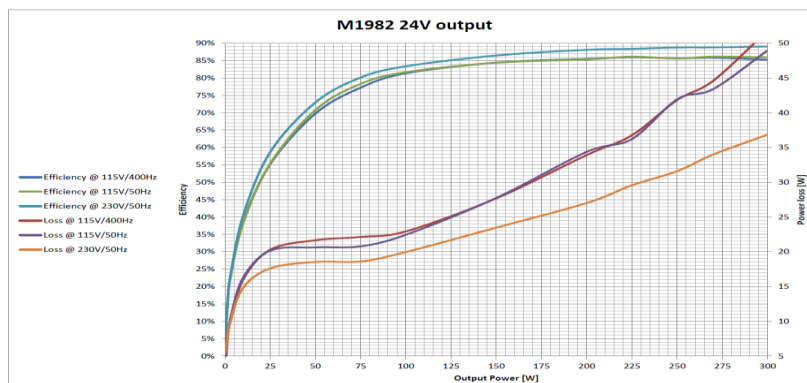

### Pin Assignment

#### J1 - Input connector

Type: M24308/24-37F or eq.

Mates with: M24308/2-1F or eq.

Pin No.	Function	
1	NEUTRAL	•
2	N/C	
3	PHASE	•
4	N/C	
5	CHASSIS	•
6	NEUTRAL	•
7	N/C	
8	PHASE	•
9	N/C	

#### J2 - Output connector

Type: M24308/23-38F or eq.

Mates with: M24308/4-2F or eq.

Pin No.	Function	
1	SYNC	•
2	INHIBIT	•
3	SENSE RTN	•
4	OUTPUT RTN	•
5	OUTPUT RTN	•
6	OUTPUT	•
7	OUTPUT	•
8	SENSE	•
9	SIGNAL RTN	•

Pin No.	Function	
10	OUTPUT RTN	•
11	OUTPUT RTN	•
12	OUTPUT RTN	•
13	OUTPUT	•
14	OUTPUT	•
15	OUTPUT	•

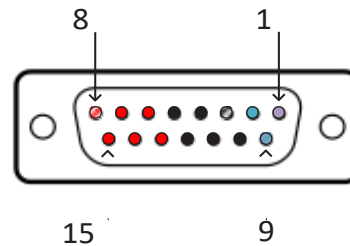
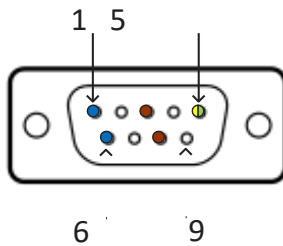

(Connectors shown from front view)

### Functions and Signals

#### SENSE

The SENSE line is used to achieve accurate voltage regulation at load terminals. To use this feature, connect this pin directly to load's positive terminal. If this function is not required, short SENSE pin to OUTPUT pins as close as possible to the unit.

#### SENSE RTN

The SENSE RTN line is used to achieve accurate voltage regulation at load terminals. To use this feature, connect this pin directly to load's negative terminal. If this function is not required, short SENSE RTN pin to OUTPUT RTN pins as close as possible to the unit.

Note: The use of remote sense has a limit of voltage dropout between the converter's output and the load's terminals of approximately 5% of nominal output voltage.

#### INHIBIT

The INHIBIT signal is used to turn the power supply ON and OFF. TTL "1" or OPEN – Power supply active (output turned on). TTL "0" or SHORT to Signal RTN – Power supply inhibited (output turned off). If this function is not required, leave this pin unconnected.

#### SYNC

The SYNC signal is used to synchronize the power supply's switching frequency to system's clock. Valid external clock frequency is  $250\text{kHz} \pm 10\text{kHz}$ . If this function is not required, leave this pin unconnected - the power supply will use its internal clock.

#### SIGNAL RTN

Both INHIBIT and SYNC signals are referenced to this pin. This pin is floating from both input and output.

#### CHASSIS

The CHASSIS pin allows additional connection of unit's chassis to system ground.

### Typical Connection Diagram

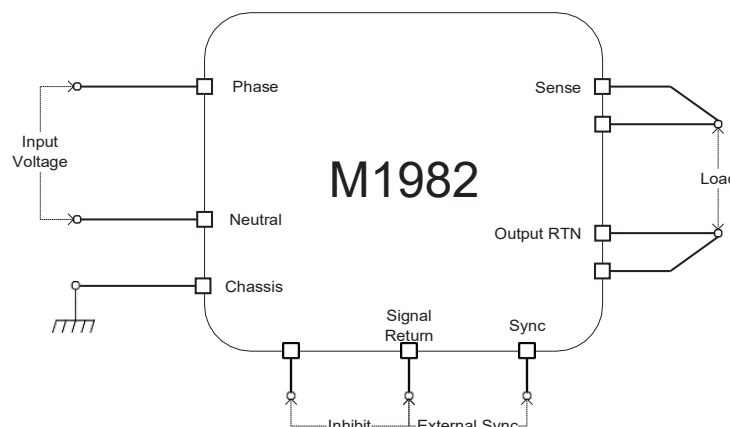

## M1982 AC/DC POWER SUPPLY

### Outline Drawing

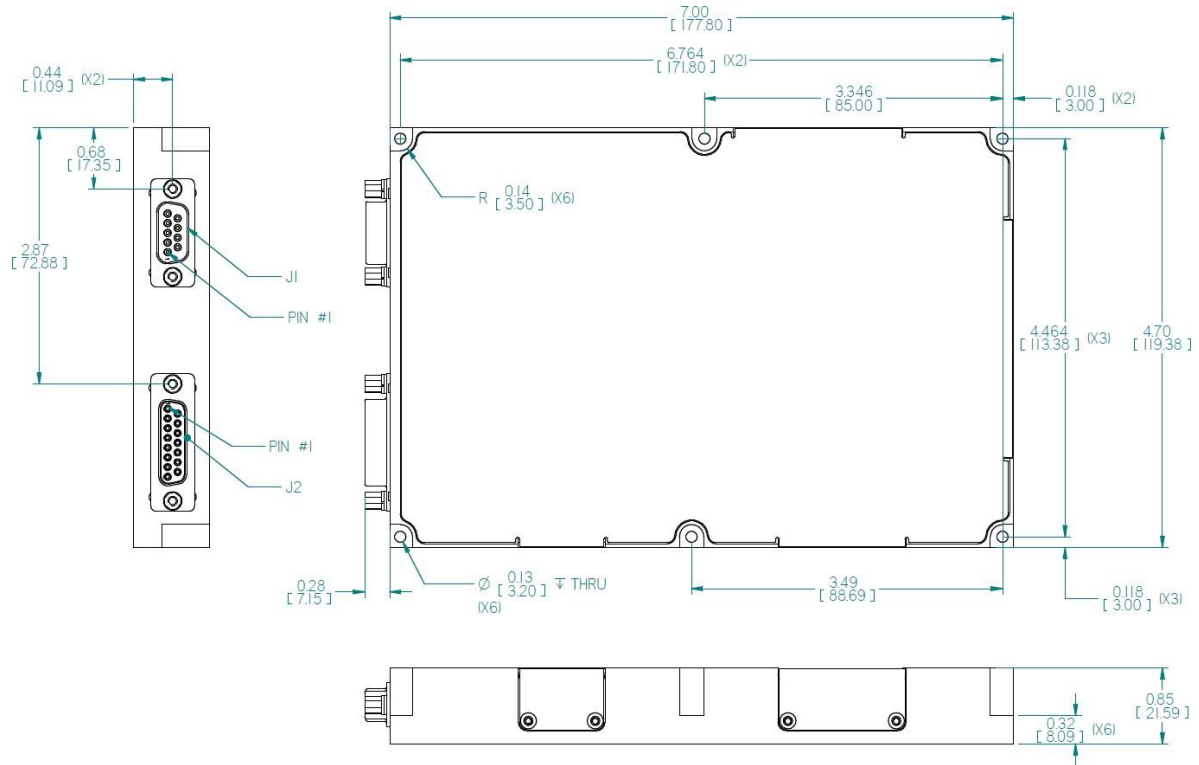

#### Notes

1. Dimensions are in inches [mm]
2. Tolerance is:  
 .XX  $\pm$  0.03 in  
 .XXX  $\pm$  0.010 in
3. Weight: Approx. 27.16 oz [770 g]

### Heat Dissipation Surface

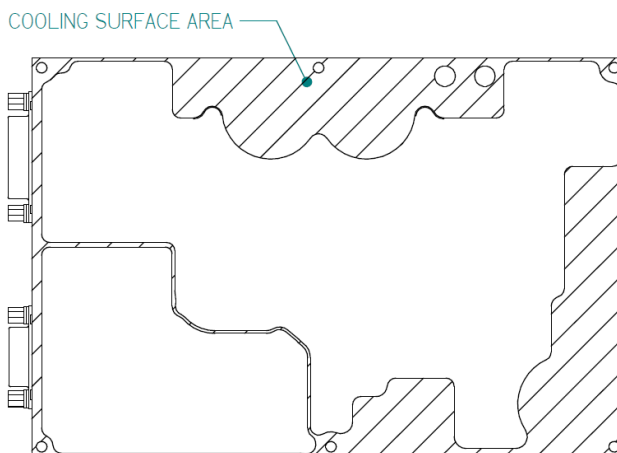

Dissipation Area  
 9.1 in<sup>2</sup>  
 [5871 mm<sup>2</sup>]

### Standard Configurations

Model	Output
M1982100	5V / 20A
M1982101	12V / 20A
M1982102	15V / 20A
M1982103	24V / 12.5A
M1982104	28V / 10.7A
M1982105	48V / 6.2A

- Additional standard configurations available, please consult factory for details

*Note: Specifications are subject to change without prior notice by the manufacturer.*