

M4252 SERIES

DC/AC INVERTER



PRODUCT HIGHLIGHTS

- MINIATURE, HIGH DENSITY
- PURE SINE WAVE
- DC/AC INVERTER
- 18 to 70 VDC Input
- UP TO 350 VA CONT./500 VA PEAK

M4252 SERIES DC/AC INVERTER

Applications

Military (Airborne, ground-fix, shipboard), Ruggedized, Telecom, Industrial Power Supply

Special Features

- Miniature size
- High efficiency
- Wide input range
- Input / Output isolation
- Remote Inhibit (On/Off)
- Fixed switching freq. (250 kHz)
- External sync. capability
- EMI filters included
- Non-latching protection:
 - Short-circuit / Overload
 - Output over-voltage
 - Over temperature

Electrical Specifications

DC Input

Normal range: 18 to 70 V_{DC}

Output Voltage Regulation

Less than ±3% (no load to full load, -40°C to +85°C).

AC Output

Voltage range: 75 to 115 V_{AC}
 Current range: 0 to 3.5 A
 Power range: 0 to 350 VA
 Optional Peak Power 500VA (4.5A) for 45sec at 28V input
Please consult factory for details.

Frequency: 50 / 60 / 400 Hz

Output Waveform

Sinusoidal with max 5% (for 50,60Hz) and 7% (for 400Hz) harmonic distortion into a resistive load.

Efficiency

82 ± 1% - Typical (115 V_{AC}/400 Hz output, full load, room temperature)

79 ± 1% - Typical (115 V_{AC} /50/60 Hz output, full load, room temperature)

Isolation

Input to Output: 200 V_{DC}
 Input to Case: 200 V_{DC}
 Output to Case: 500 V_{DC}

EMC

Designed to meet[†] MIL-STD-461F: CE101, CE102, CS101, CS114, CS115, CS116, RE101, RE102, RS101, RS103

Turn-On Transient

Soft Start – no voltage overshoot.

[†] Compliance achieved with 5µH LISN shielded harness and static resistive load.

M4252 SERIES DC/AC INVERTER

Protections *

Input

- **Under Voltage Lock-Out**
Unit shuts down when input voltage falls below $17 V_{DC} \pm 1V$
- **Over Voltage Lock-Out**
Unit shuts down when input voltage exceeds $82 V_{DC} \pm 2V$

Output

- **Overvoltage Protection**
Shuts down if output voltage exceeds $110\% \pm 5\%$ of nominal voltage due to internal failure.
- **Current Limiting**
Output hiccups as long as overload ($120\% \pm 10\%$ of nominal) or short-circuit condition exists.

General

- **Over Temperature Protection**
Shutdown if baseplate temperature exceeds $+105 \pm 5 \text{ }^\circ\text{C}$.
Automatic recovery upon cooldown to below $+95 \pm 5 \text{ }^\circ\text{C}$.

Environmental Conditions

Designed to meet MIL-STD-810F

Temperature

Methods 501.4 & 502.4
Operating: $-40 \text{ }^\circ\text{C}$ to $+85 \text{ }^\circ\text{C}$ (at baseplate)
Storage: $-55 \text{ }^\circ\text{C}$ to $+125 \text{ }^\circ\text{C}$ (ambient)

Altitude

Method 500.4
Procedures I – Storage/Air transport: up to 70,000 ft. (non-operational)
Procedure II – Operation/Air Carriage: up to 70,000 ft. (operational)

Humidity

Method 507.4
Up to 95% RH

Salt Fog

Method 509.4

Vibration

Method 514.5
General minimum integrity exposure
IAW Figure 514.5C-17 1 hour per axis.

Shock

Method 516.5
20 g, 11 ms terminal peak saw-tooth
Optional: 40, 11ms saw-tooth. **Please consult factory for details.**

Reliability

150,000 hours, calculated IAW MIL-HDBK-217F Notice 2 at $+85 \text{ }^\circ\text{C}$ baseplate, Ground Fixed conditions.

* Thresholds and protections can be modified / removed – please consult factory.

M4252 SERIES DC/AC INVERTER

Pin Assignment

J1 - Input connector

Connector type: M24308/24-39F or eq.

Mates with: M24308/2-3F or eq.

Pin No.	Function	P
1	SYNC OUT RTN	-
2	SYNC IN	+
3	INHIBIT	+
4	VIN	+
5	VIN	+
6	VIN	+
7	VIN	+
8	VIN	+
9	VIN RTN	-
10	VIN RTN	-
11	VIN RTN	-
12	VIN RTN	-
13	VIN RTN	-

Pin No.	Function	P
14	SYNC OUT	+
15	SYNC IN RTN	-
16	SIGNAL IN RTN	-
17	VIN	+
18	VIN	+
19	VIN	+
20	VIN	+
21	VIN RTN	-
22	VIN RTN	-
23	VIN RTN	-
24	VIN RTN	-
25	CHASSIS	

J2 - Output connector

Connector type: M24308/23-39F or eq.

Mates with: M24308/4-3F or eq.

Pin No.	Function	P
1	START 120	+
2		
3	START 240 RTN	-
4		
5	SIGNAL OUT RTN	-
6	FREQ SELECT A	+
7	MASTER / SLAVE	+
8		
9		
10	NEUTRAL OUT	0
11		
12		
13	PHASE OUT	~

Pin No.	Function	P
14	START 120 RTN	-
15		
16	START 240	+
17		
18	FREQ SELECT B	+
19	START 0	+
20		
21		
22	NEUTRAL OUT	0
23		
24		
25	PHASE OUT	~

M4252 SERIES DC/AC INVERTER

Functions and Signals

INHIBIT (connector J1, pin 3)

The ***INHIBIT*** signal is used to turn the power supply ON or OFF.

TTL "1" or OPEN – power supply turns ON (For always-on operation, leave this pin unconnected). TTL "0" or SHORT to ***SIGNAL IN RTN*** – power supply turns OFF.

This signal is referenced to ***SIGNAL IN RTN*** pin (connector J1, pin 16).

SYNC IN (connector J1, pin 2)

The ***SYNC IN*** signal is used to synchronize the power supply's switching frequency to an external clock. The external clock frequency is allowed to be 250 kHz \pm 10 kHz, with duty-cycle of 50% \pm 10%.

When not connected, the power supply will synchronize to its internal clock, set at 250 kHz \pm 10 kHz. This signal is referenced to ***SYNC IN RTN*** pin (connector J1, pin 15).

SYNC OUT (connector J1, pin 14)

The ***SYNC OUT*** signal is a buffered clock signal that can be used to synchronize other power supplies to the power supply's switching frequency. This feature can be used in a master/slave setup – see typical 3-phase connection diagrams for more information.

This signal is referenced to ***SYNC OUT RTN*** pin (connector J1, pin 1).

MASTER / SLAVE (connector J2, pin 7)

This signal is used in a three-phase setup – see typical 3-phase connection diagrams for more information.

This signal is referenced to ***SIG OUT RTN*** pin (connector J2, pin 5).

START 0, START 120, START 240 (connector J2, pins 19, 1 and 16 respectively)

These signals are used in a three-phase setup – see typical 3-phase connection diagrams for more information.

Chassis (connector J1, pin 25)

This pin is connected to the converter's chassis.

FREQ SELECT A, FREQ SELECT B (connector J2, pins 6 & 18, respectively)

These pins are used to set the output frequency according to the following truth table:

Frequency	FREQ SELECT A (Pin 6)	FREQ SELECT B (Pin 18)
400 Hz	0	0
60 Hz	1	0
50 Hz	0	1
Off	1	1

"0" means the pin is shorted to its reference, "1" means pin is left open. These pins are referenced to ***SIGNAL OUT RTN*** pin (connector J2, pin 5).

M4252 SERIES DC/AC INVERTER

Single-Phase Typical Connection

In this example, the unit is configured to 115 V_{AC}/ 400 Hz

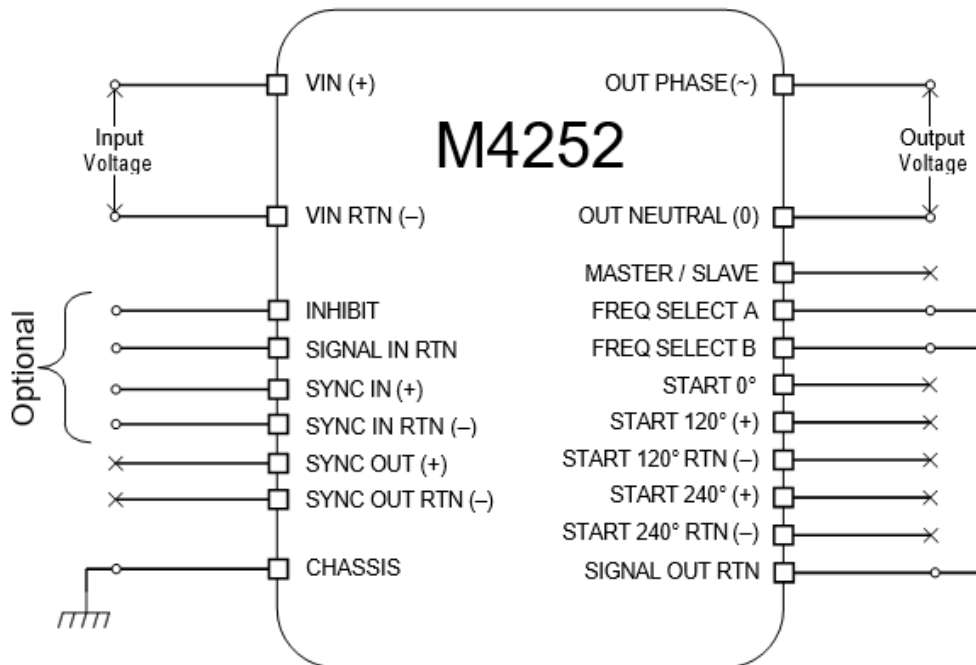

M4252 SERIES DC/AC INVERTER

Three-Phase Wye Typical Connection

In this example, the units are configured to 115 V_{line-neutral} / 200 V_{line-line}, 60 Hz Wye connection

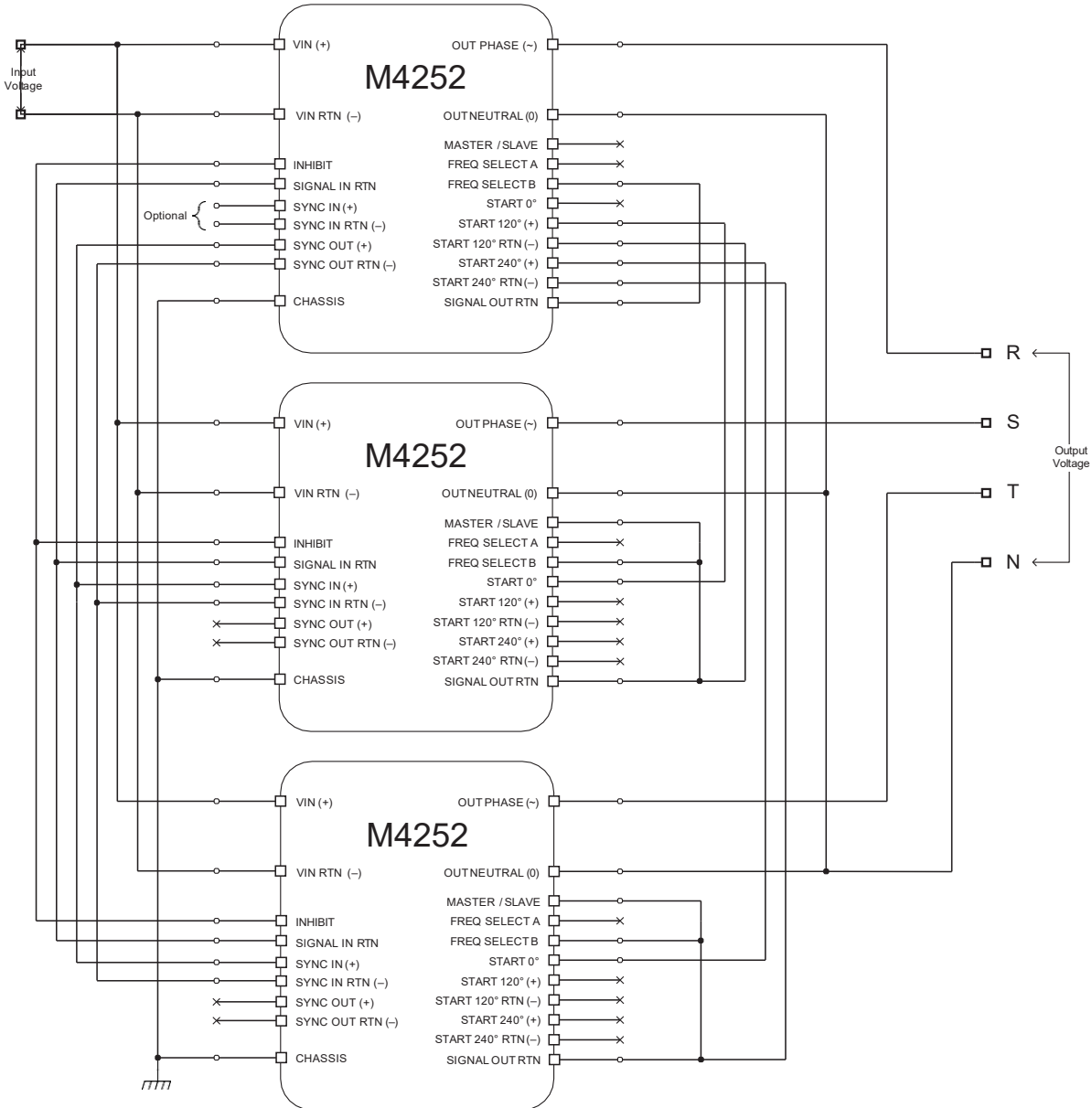

M4252 SERIES DC/AC INVERTER

Three-Phase Delta Typical Connection

In this example, the units are configured to 115 V_{line-line}, 50 Hz Delta connection

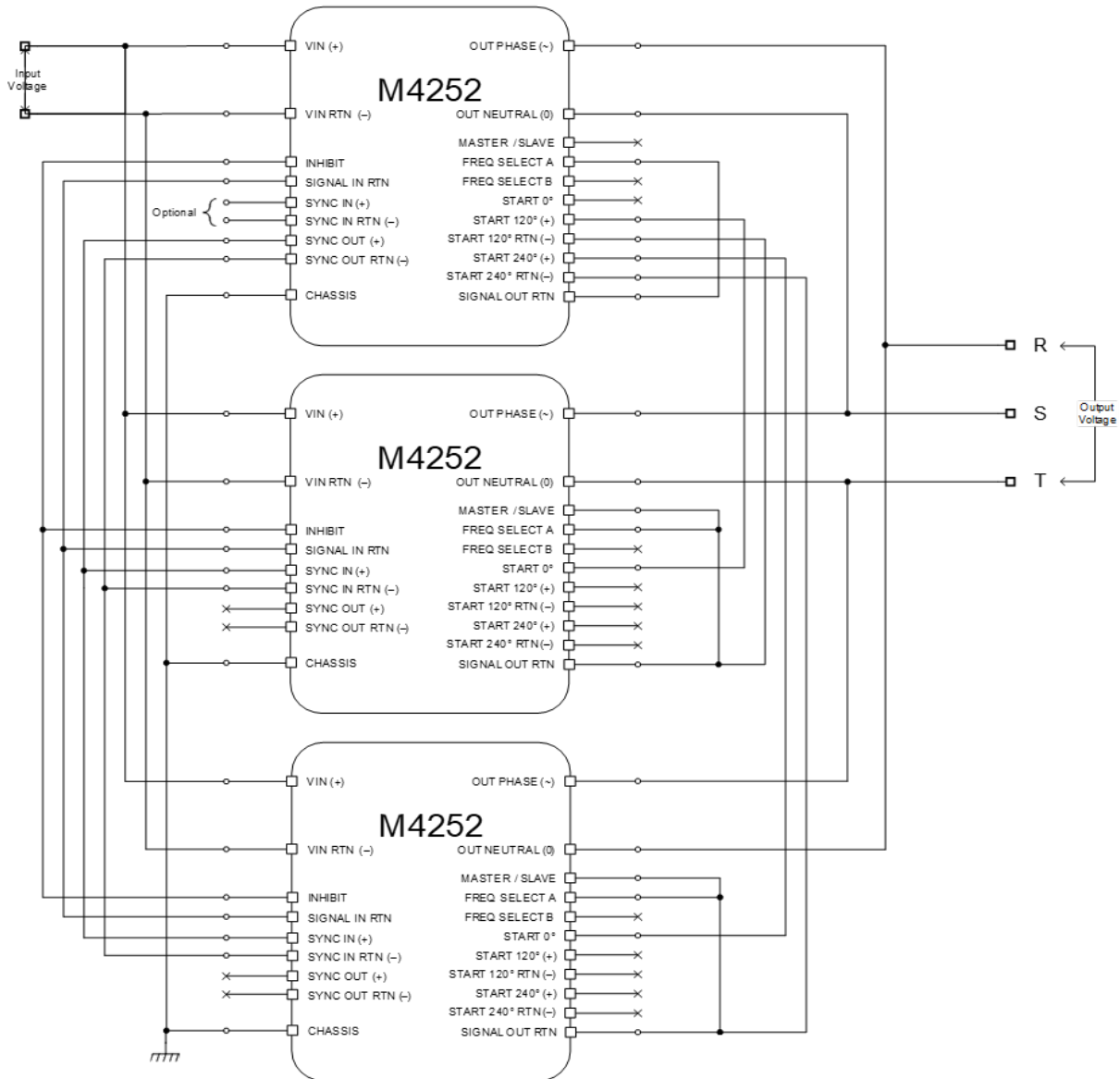

M4252 SERIES DC/AC INVERTER

Outline Drawing

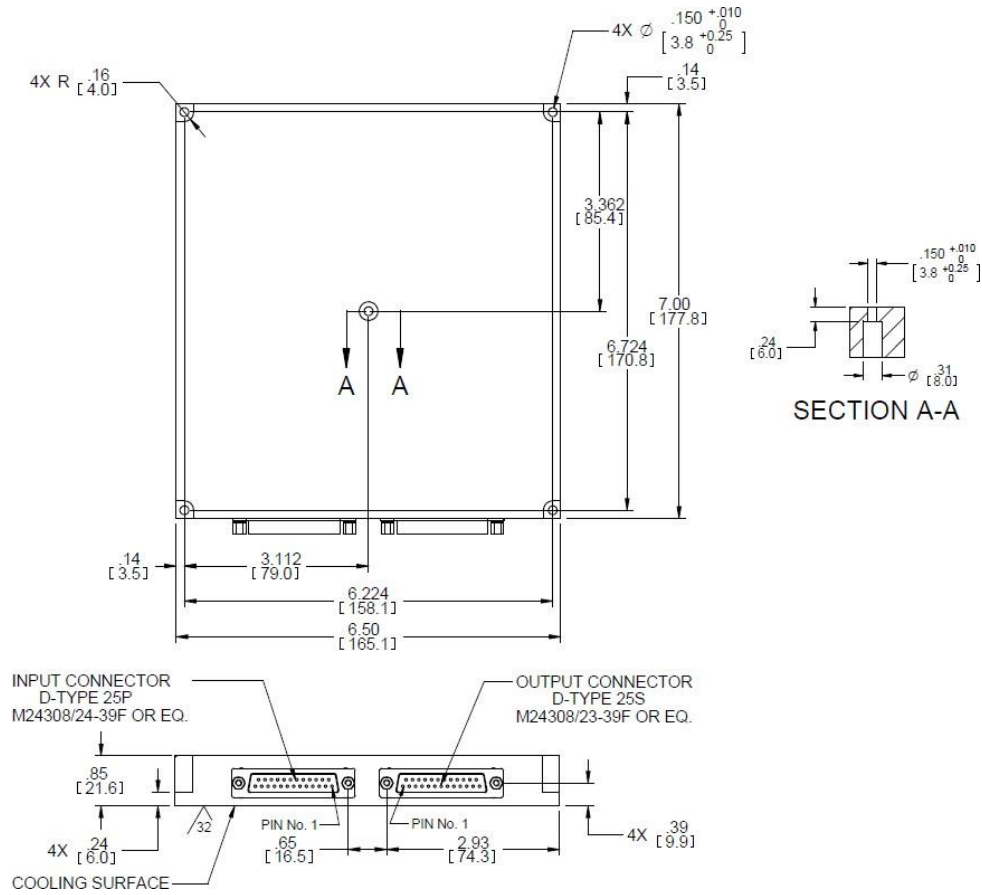

Heat Dissipation Surface

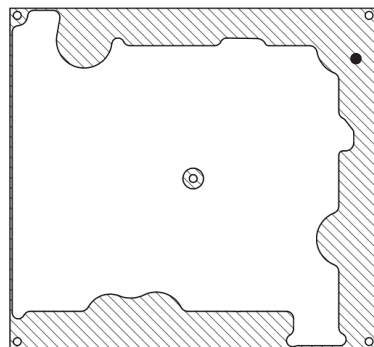

Dissipation Area
13.78 in²
[8890 mm²]

Notes

1. Dimensions are in inches [mm]
2. Tolerance is:
.XX ± 0.01 in
.XXX ± 0.005 in
3. Weight: Approx. 37 oz [1050 g]

M4252 SERIES DC/AC INVERTER

Standard Configurations

Part number	Input	Output		
	Voltage Input range	Voltage	Frequency	Current
M4252100	18 to 70 V _{DC}	115 V _{AC}	50/60/400Hz	3 A
M4252800	18 to 70 V _{DC}	115 V _{AC}	50/60/400Hz	3 A

Special Features

- **M4252800:** this variant is REACH Compliant
- **M4252800:** The aluminum parts comprising this variant are chromate conversion coated per MIL-DTL-5541F, Type II CLASS 1A or eq.
- **M4252800:** The shell of the connectors are Zinc:
 - **J1 - Input connector:** M24308/24-39Z
 - **J2 - Output connector:** M24308/23-39Z

Note: Specifications are subject to change without prior notice by the manufacturer