

M4465 SERIES

DC/DC POWER SUPPLY

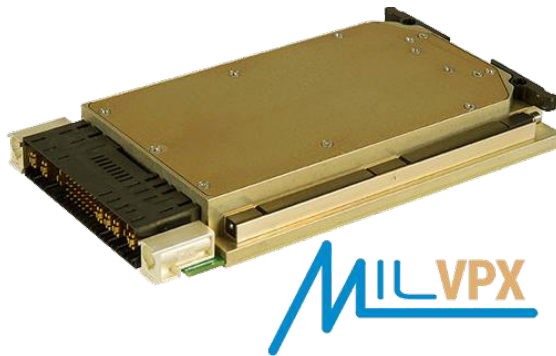

PRODUCT HIGHLIGHTS

- **VITA 62 COMPLIANT**
- **3U VPX FORM FACTOR**
- **DC/DC CONVERTER**
- **6 OUTPUTS**
- **600W (700W PEAK)**
- **Input Options:**
 - **MIL-STD-704**
 - **MIL-STD-1275**
 - **DEF-STAN 61-5**
- **Cyber secure**

M4465 SERIES VPX DC/DC POWER SUPPLY

Special Features

- VITA 62 compliant
- Wide input range
- Remote sense
- Fixed switching frequency (250khz)
- External synchronization capability
- Indefinite short circuit Protection
- Over-voltage shutdown with auto-recovery
- Reverse battery protection
- Over temperature shutdown with auto-recovery
- EMI filters included
- IPMI communication

Electrical Specifications

DC Input

18 to 48 V_{DC}
Max Non-Operating 100V
Options:

- 1) MIL-STD-704 (A-F)
Normal and Abnormal Steady State
- 2) MIL-STD-704(A-F)
transients Up to 50V, 80V.
- 3) MIL-STD-704(A-F)
Transients Under 18V and Starting transients.
- 4) MIL-STD-1275 Surges
- 5) Def Stan 61-5 170V Load Dump

DC Output

VS1: 12V up to 30A
VS2: 3.3V up to 20A
VS3: 5V up to 30A
12V_Aux: 12V up to 1A
-12V_Aux: -12V up to 1A
3.3V_Aux: 3.3V up to 5A

Efficiency

Up to 88%
85.5 % @ Full Load
(See Para. 4)
Typical 84% at 1275E configuration

Isolation

Over 20 MΩ at test voltage:
200V between Input and Output
200V between Input and Case
100V between Output and Case

EMC

Complies with MIL-STD-461F (5μH LISN): CE101, CE102, CS101, CS114, CS115, CS116

Line/Load regulation

See table 2 on page 7

Ripple and Noise

Typically, less than 50mV_{p-p} (max. 1%_p). Measured across a 0.1μF capacitor and 10μF capacitor on load at Input Voltage of 18V-36V, all Temperature Range.

Load Transient Overshoot and Undershoot

Output dynamic response of less than 5% at load Step of 30%-60%.
Output returns to regulation in less than 1mSec

Communication

I2C protocol available for voltages, currents and temperature for all positive voltages (GAX, SCL, SDA)

M4465 SERIES VPX DC/DC POWER SUPPLY

Environmental¹

Design to Meet MIL-STD-810G

Temperature

Operating: -55 °C to +85 °C
at unit edge
Storage: -55 °C to +125 °C

Altitude

Method 500.5, Procedure I & II
Storage/Air Transport: 40 kft
Operation/Air carriage: 70 kft

Salt Fog:

Method 509.5

Fungus

Does not support fungus growth, in accordance with the guidelines of MIL-STD-454, Requirement 4.

Humidity

Method 507.5, Up to 95% RH

Shock

Method 516.6
40g, 11msec saw-tooth
(all directions)

Vibration

Vibration: Figure 514.6E-1. General minimum integrity exposure. (1 hour per axis.)

Reliability: 308,000 Hours, calculated IAW MIL-HDBK-217F Notice 2 at +65 °C, GF.

Note 1: **Environmental Stress Screening (ESS)** Including random vibration and thermal cycles is also available. **Please consult factory for details.**

Protections[‡]

Input

Input Reverse Polarity:
Protection for unlimited time

Inrush Current Limiter
Peak value of $5 \times I_{IN}$ for initial inrush currents lasting more than 50 μ Sec.

Under Voltage
Unit shuts down when input voltage drops below 17 ± 0.5 VDC.
Automatic restart when input voltage returns to nominal range.

Over Voltage Lock-Out
Unit shuts down when input steady state voltage rise above 55 ± 2 VDC.
Automatic restart when input voltage returns to nominal range.

Output

Passive over voltage protection on Aux outputs
Zener selected at $25\% \pm 5\%$ above nominal voltage, is placed across the output for passive voltage limit.

Active over voltage protection on VS# outputs
 $20\% \pm 5\%$ above nominal voltage.
Automatic recovery when output voltage drops below threshold.

Overload / Short-Circuit Protection
Continuous Hiccup protection (110-130%) for VS#.
Aux Typical:
3.3Vaux / 8A
12Vaux. 1.5A-2A
-12Vaux. 2.5A-3A

General

Over Temperature Protection
Automatic shutdown at temperature of 95 ± 5 °C (at unit edge)
Automatic recovery when temperature drops below 90 ± 5 °C.

Note 1: Thresholds and protections can be modified / removed (please consult factory)

Functions and Signals - According to VITA 62

Signal No.	Signal Name	Type	Description
1	FAIL*	Output	Indicates to other modules in the system that a failure has occurred in one of the outputs. Please refer to Figure 2 This signal is referenced to SIGNAL RTN .
2	SYSRST*	Output	Indicates to other modules in the system that all outputs are within their working level. Please refer to Figure 2 This signal is referenced to SIGNAL RTN .
3	INHIBIT*	Input	Controls power supply outputs. This signal in conjunction with INHIBIT controls the outputs. Please refer to Table 1 and Figure 1 This signal is referenced to SIGNAL RTN .
4	ENABLE*	Input	Controls power supply outputs. This signal in conjunction with INHIBIT controls the outputs. Please refer to Table 1 and Figure 1 This signal is referenced to SIGNAL RTN .
5	GA0*, GA1	Input	Used for geographical addressing. GA1 is the most significant bit and GA0 is the least significant bit. This signal is referenced to SIGNAL RTN .
6	SCL, SDA	Bidirectional	I2C bus Clock and Data respectively. Through this bus the voltage and temperature readouts can be shared. This signal is referenced to SIGNAL RTN .
7	REF_CLK	Input	The REF_CLK signal is used to allow the power supply frequency to sync with the system frequency. This signal is referenced to SIGNAL RTN .
8	VOUT SENSE	Input	The SENSE is used to achieve accurate load regulations at load terminals (this is done by connecting the pins directly to the load's terminals).

Table 1 – Inhibit and Enable Functionality

INHIBIT*	Low	Low	High	High
ENABLE*	Low	High	Low	High
VS1, VS2, VS3, ±12VAux	OFF	OFF	ON	OFF
3.3V_AUX	ON	OFF	ON	OFF

Figure 1 – Inhibit and Enable Input stage

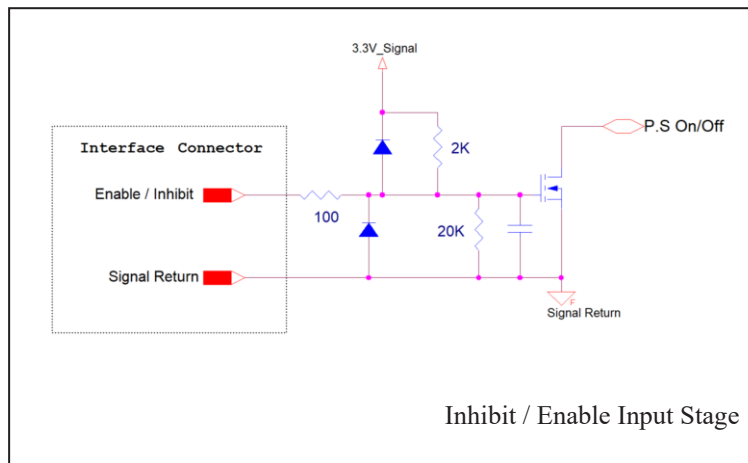
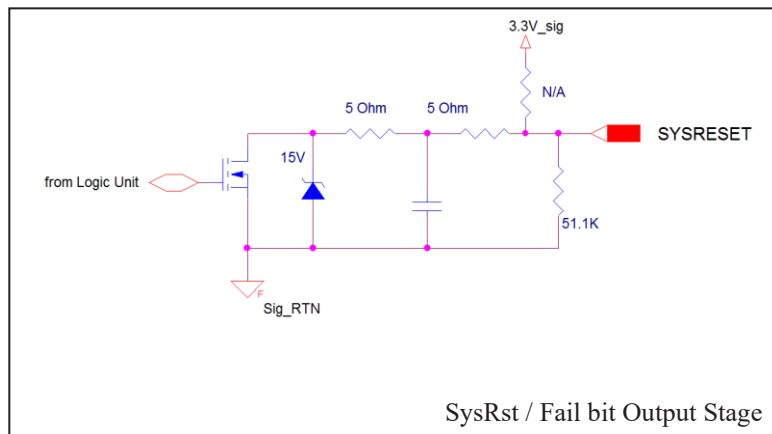
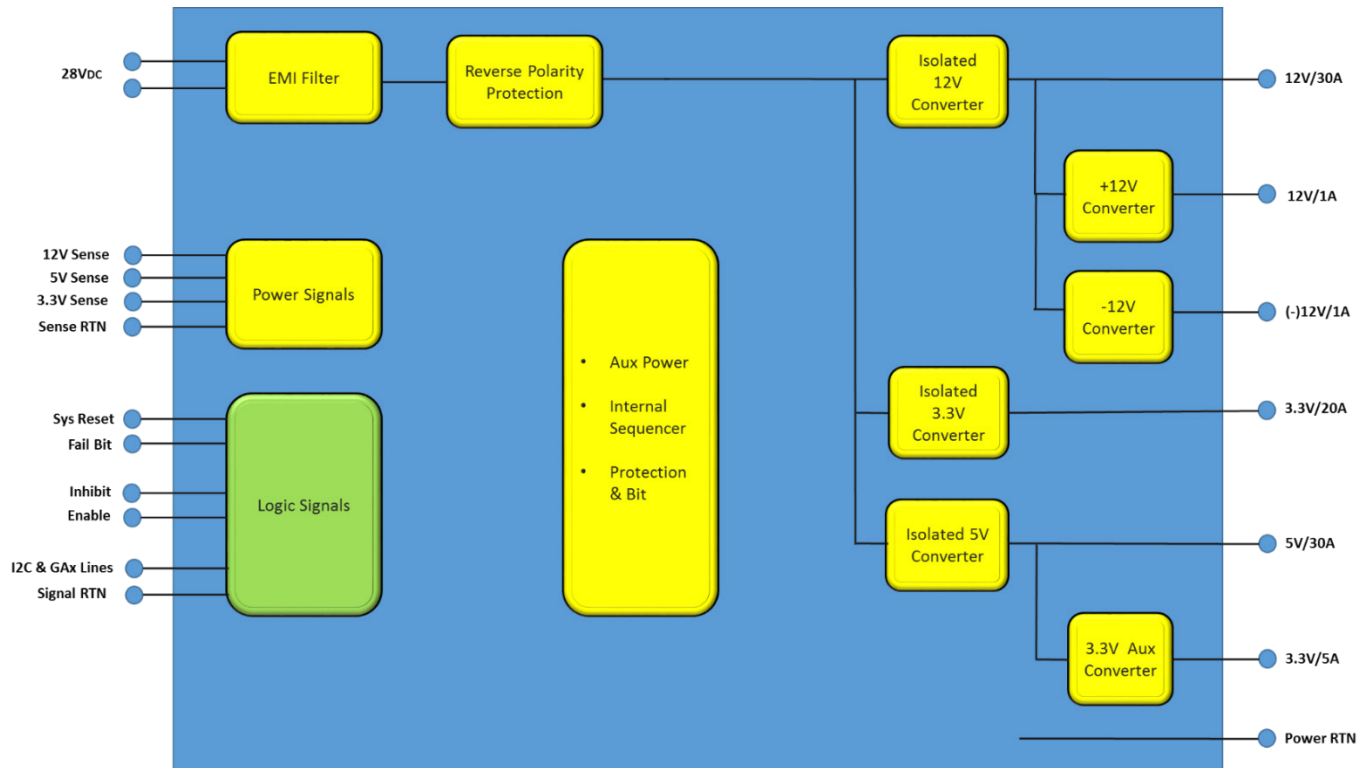

Figure 2 – SysRst and Fail Bit output storage



Simplified Block Diagram



M4465 SERIES VPX DC/DC POWER SUPPLY

Detailed Information

1. M4465 Input Voltage Operation.

The M4465 steady state operation voltage is 18V to 48 V and will continuously work up to 50V Input line.

When Configurable to support MIL-STD 704/1275 transients or surges, the unit will shut down when input voltage rises above 60V or under 16V for more than 2Sec and immediate shut down under 12V or above 100V Input. Power supply automatically recover when it's Input goes back to normal steady state line.

Note: 1275E configuration is optional, contact Factory.

1.1 Low Line Turn-on and Turn-off Limits

To avoid Turn-on and Turn-off cycling glitch the unit have about 2V Hysteresis. The Turn-on threshold is under 20V and turn- off under 18V.

Those limits can be adjusted, contact Factory for more information.

2. Outputs Voltage Regulation

The M4465 contains accurate internal sense lines to keep output voltage at less than 4% regulation for all Line/ Load and temperature range (see Table 2).

Output	12V/25A	5V/30A	3.3V/20A	3.3VAux/5A	12VAux/1A	(-)12VAux/1A
Voltage Range	11.85 – 12.15	4.9 – 5.1	3.28 – 3.42	3.2 – 3.4	11.7 – 12.2	(-)11.85 – (-)12.15

Table 2: Outputs voltage regulation. VIN 18V – 48V, Temperature -55 °C – 85 °C

2.1. Sense Lines

Sense Lines are provided for VS1, VS2 and VS3 output to compensate line voltage drop. *Sense Lines* proper connection is shown in Figure 3.

Each VSx output has its own *Sense Lines*, additional common *Sense RTN Line* is provided for all VSx Outputs (VITA 62 Standard).

Contact Factory for Sense configuration different than the VITA 62 standard

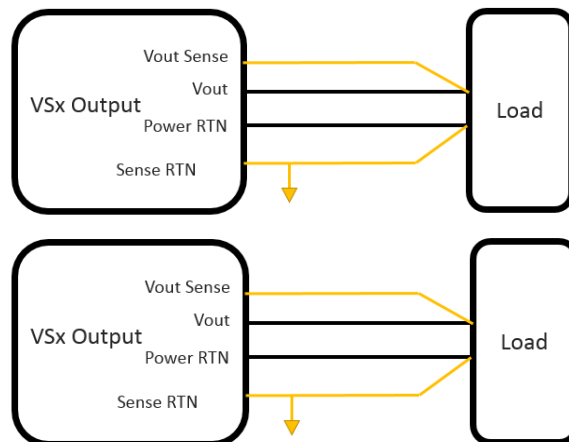

Figure 3: M4465 Sense line connection

M4465 SERIES VPX DC/DC POWER SUPPLY

3 Output Power

The M4465 can deliver up to 600W steady State at all temperature and input range, 550W is available for Mil-STD-1275E configuration. Peak power of 700W, please contact factory for more details and limitations.

Total Power Output	12V/30A	5V/30A	3.3V/20A	3.3VAux/5A	12VAux/1A	(-)12VAux/1A
600W	30A	30A	20A	5A	1A	1A
700W	40A	35A	20A	5A	1A	1A

Table 3a: M4465 current per output at steady state and peak

Total Power Output	12V/25A	5V/30A	3.3V/20A	3.3VAux/5A	12VAux/1A	(-)12VAux/1A
550W	25A	30A	20A	5A	1A	1A

Table 3b: M4465 current per output at 1275E configuration

3.1 Mil-STD 1275E Surges

The Unit can support up to 500W during 12V surge. Operating the unit at higher power may result in a poor output transient response during the surge.

Total Power Output	12V/25A ¹	5V/30A	3.3V/20A	3.3VAux/5A	12VAux/1A	(-)12VAux/1A
550W	22A	30A	20A	5A	1A	1A

Table 4: Max current per output during 12V surge

Note 1: Max total current of 12V rail (12Vvs1, 12VAux & (-) 12VAux) should not exceed 22A in order to stay in spec regulation

Figure 4a/b shows 12VSI output during 100V and 12V surges.

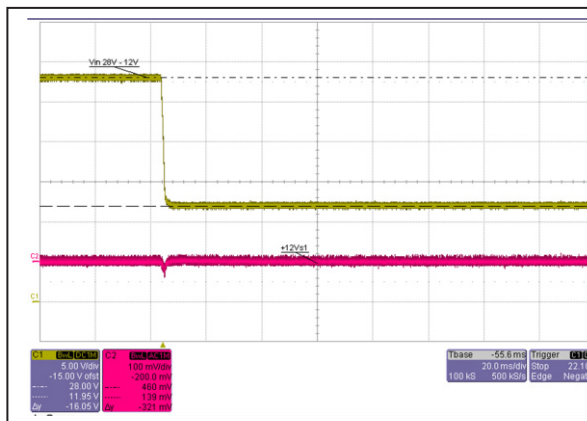

Figure 4a: VS1 during 12V Line surge

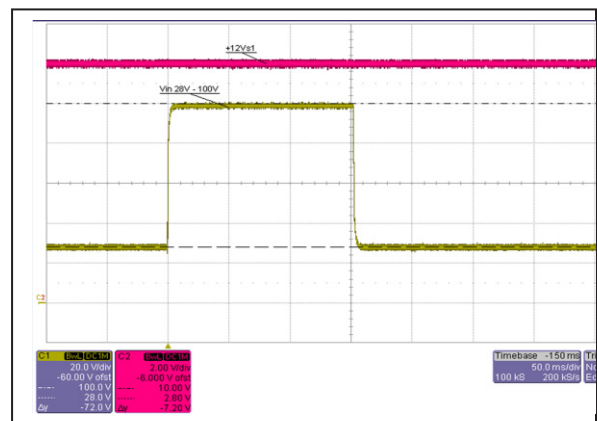

Figure 4b: VS1 during 100V Line surge

3.2 Units efficiency (Typical results at room temperature)

Input Voltage	Output Power	Efficiency
28V	170W	88%
	200W	87.6%
	600W	86.1%

3 Typical EMI Tests

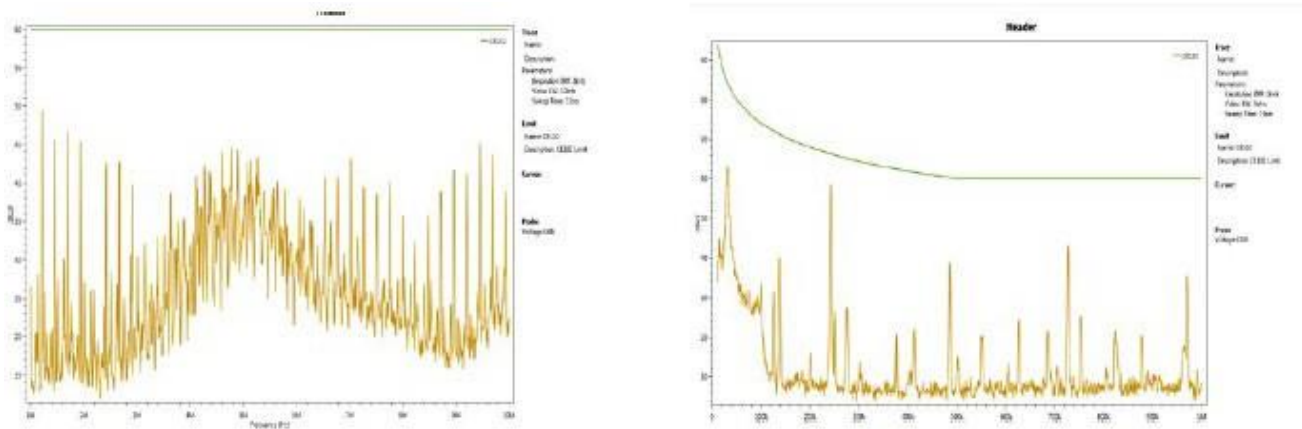

Figure 5: 28V Line, Full Load, 5UH LISN

4 Advanced I2C With Global Addressing Protocol

Electrical Parameters

Vcc: 3.3VDC
 Pull-up: 10kOhm
 Input capacitance: 330pf

Slave Device Addressing

- 256 address spaces
- Baud rate: 200kHz maximum
- 7 Bit Protocol
- Support Slot Addressing per VITA 62

	MSB							LSB
Slot Number	A6	A5	A4	A3	A2	A1/*GA1	A0/*GA0	R/W
Slot0	0	1	0	0	0	0	0	
Slot1	0	1	0	0	0	0	1	
Slot2	0	1	0	0	0	1	0	
Slot3	0	1	0	0	0	1	1	

* Slot location is determined by GAx per VITA 62.

Communications Supported

Read Command – 21Hex, deliver 64Bytes of Data. (More commands are available by request)
 The communication starts when the master sends a start followed by the unit slave address, command, checksum and a stop. A second start followed by the slave address and a read will be followed by a 64 Bytes response.

S	Slave Address	R/W	A	Command	A	Check sum	A	P
	A6:A0	0	0	21 Hex	0	DF Hex	0	

S	Slave Address	R/W	A	DATA	A	DATA	A	DATA	A	...	DATA	A	Check sum	N/A	P
	A6:A0	1	0	D7:D0	0	D7:D0	0	D7:D0	0		D7:D0	0	D7:D0	1	

Command – 21Hex read all 64 Bytes
 S – Start
 P – Stop

Master Transmit	Unit Transmit

M4465 SERIES VPX DC/DC POWER SUPPLY

Memory Space

Response Byte #	Data Type	Meaning	Interpretation	Reading Range
0	U Integer, MSB First	Echo of Command		21 Hex
1		N/A		00 Hex
2-3	S Integer, MSB First	Temperature -55C to 120C	T(C°)=+/- 7bit Dec	-55 C° to 125 C°
3		N/A		00 Hex
4-5	U Integer, MSB First	12V VS1 Voltage	V(out) = Data· m2	20.48V
6-7	U Integer, MSB First	3.3V VS2 Voltage	V(out) = Data· m2	20.48V
8-9	U Integer, MSB First	5V VS2 Voltage	V(out) = Data· m2	20.48V
10-11	U Integer, MSB First	3.3V Aux Voltage	V(out) = Data· m2	20.48V
12-13	U Integer, MSB First	12V Aux Voltage	V(out) = Data· m2	20.48V
14-15	U Integer, MSB First	(-)12V Aux Voltage	V(out) = Data· m2	20.48V
16-17	U Integer, MSB First	12V VS1 Current	I(out) = Data· m3	40A
18-19	U Integer, MSB First	3.3V VS2 Current	I(out) = Data· m3	40A
20-21	U Integer, MSB First	5V VS2 Current	I(out) = Data· m3	40A
22-23	U Integer, MSB First	3.3V Aux Current	I(out) = Data· m4	10A
24-35	U Integer, MSB First	12V Aux Current	I(out) = Data· m5	4A
26-27	U Integer, MSB First	(-)12V Aux Current	I(out) = Data· m5	4A
28-29	U Integer, MSB First	Reserved	00Hex	
30-31	U Integer, MSB First	Reserved	00Hex	
32-51	Character String (ASCII)	Part Number	M4465-4 (Note1)	20 Characters
52-53	Decimal, MSB First	Serial Number, 2MSB Dig	X,X Dec (Note2)	8 digits
54-55	Decimal, MSB First	Serial Number, 2LSB Dig	X,X Dec (Note2)	
56-57	Decimal, MSB First	Date Code	Week, Year (Note3)	4 digits
58-59	Character String (ASCII)	Hardware Rev	B01 & B02 Boards (Note4)	2 Characters
60-61	Decimal, MSB First	Firmware Rev	X,X,X,X Dec (Note5)	4 digits
62	U Integer, MSB First	Reserved		AA Hex
63	U Integer, MSB First	Zero Checksum	Value required to make the sum of bytes 0 to 62 added to a multiple of 256	

Note:

M2 = 20.48/65536

M3 = 40/65536

M4 = 10/65536

M5 = 4/65536

Notes 1 to 5

1. Part Number Example: M4465

Byte No'	32	33	34	35	36	37	38	39-51
Character	M	4	4	6	5	(-)	4	0
Hex	4D	34	34	36	35	2D	34	00

2. Serial Number Example: 25

Byte No'	52		53		54		55	
Dec Number	0	0	0	0	0	0	2	5
Binary	"0000"	"0000"	"0000"	"0000"	"0000"	"0000"	"0010"	"0101"

3. Date Code Example: week 35 of 2018

Byte No'	56		57	
Dec Number	3	5	1	8
Binary	"0011"	"0101"	"0001"	"1000"

4. Hardware Rev Example: B01 Rev (-), B01 Rev A

Byte No'	58	59
Character	(-)	A
Hex	2D	41

5. Firmware Rev Example: 2.1.0.0

Byte No'	60		61	
Dec Number	2	1	0	0
Binary	"0010"	"0001"	"0000"	"0000"

M4465 SERIES VPX DC/DC POWER SUPPLY

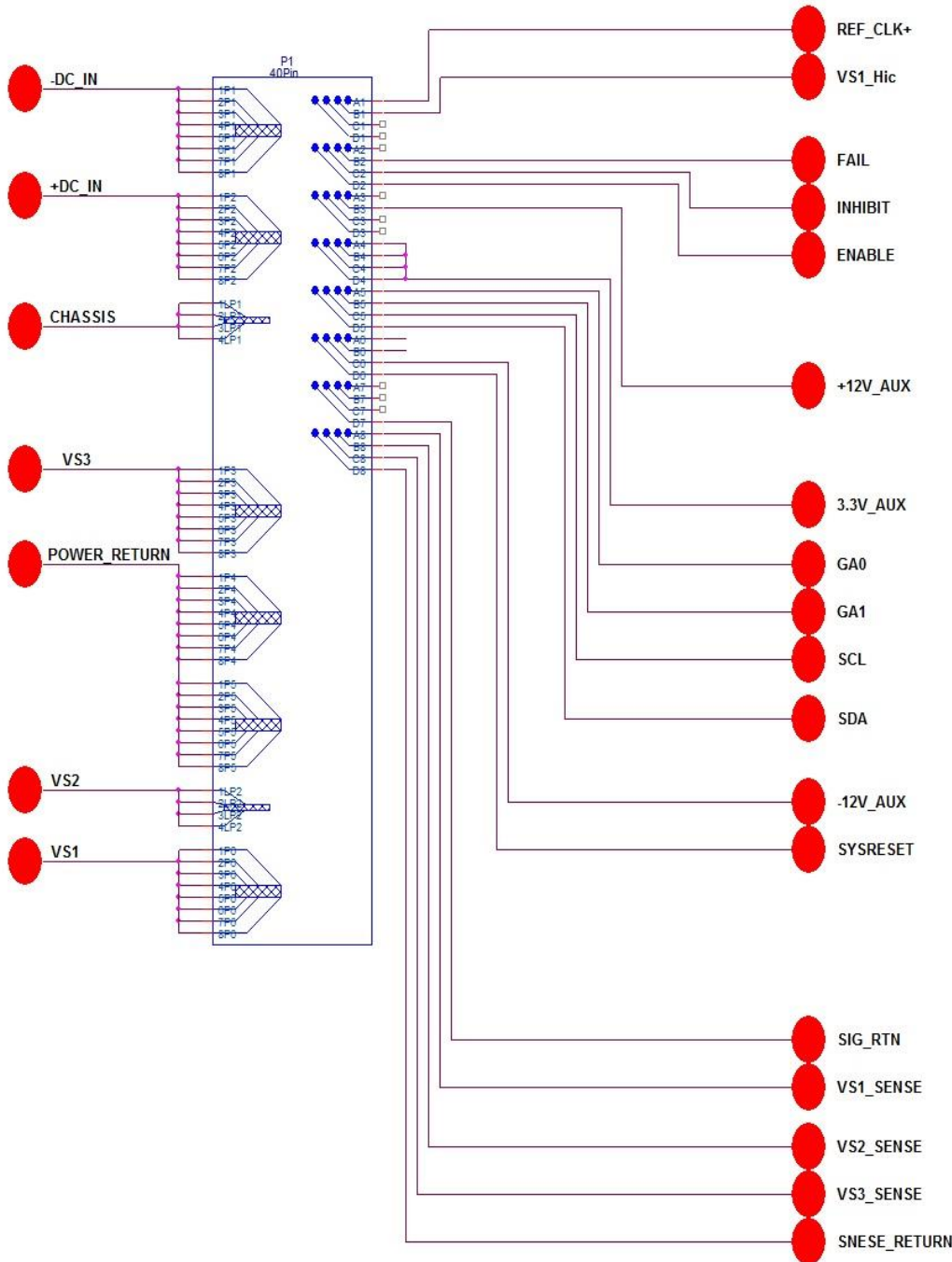

Pin Number	Pin Name
P1	-DC_IN
P2	+DC_IN
LP1	CHASSIS
P3	VS3
P4	POWER_RETURN
P5	POWER_RETURN
LP2	VS2
P6	VS1
A8	VS1_SENSE
B8	VS2_SENSE
C8	VS3_SENSE
D8	SENSE_RETURN
A7	VS1_SHARE
B7	VS2_SHARE
C7	VS3_SHARE
D7	SiG_RTN
A6	N.C
B6	N.C
C6	-12V_AUX
D6	SYSRESET*
A5	GA0*
B5	GA1*
C5	SCL
D5	SDA
A4	+3.3V_AUX
B4	+3.3V_AUX
C4	+3.3V_AUX
D4	+3.3V_AUX
A3	N.C
B3	+12V_AUX
C3	N.C
D3	N.C
A2	N.C
B2	FAIL*
C2	INHIBIT*
D2	ENABLE*
A1	REF_CLK+
B1	VS1_Hic
C1	N.C
D1	N.C

M4465 SERIES VPX DC/DC POWER SUPPLY

Outline Drawing

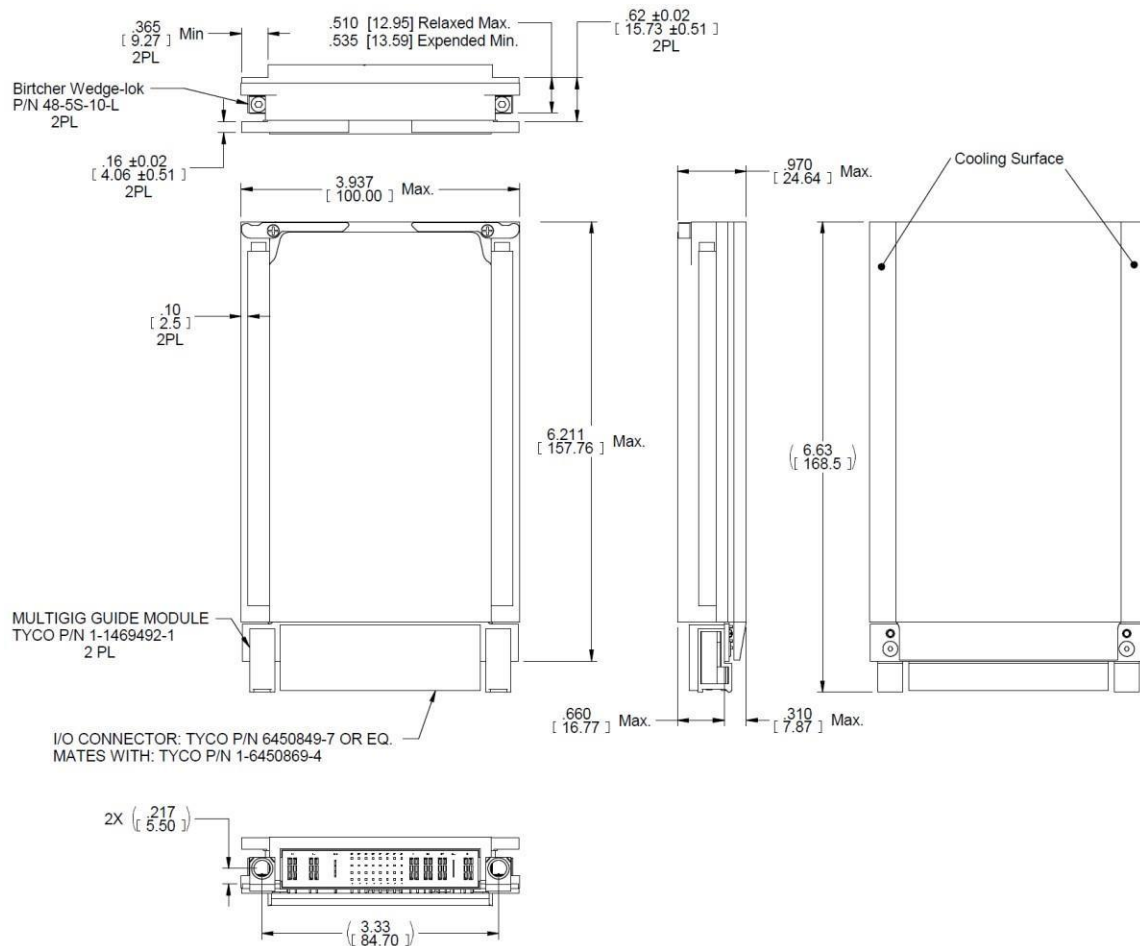

Notes

1. Dimensions are in Inches [mm]
2. Tolerance is:
 $.XX \pm 0.02$ IN
 $.XXX \pm 0.008$ IN
3. Weight: Approx. 796 g (28.08) oz
4. 3D model available

Note: Specifications are subject to change without prior notice by the manufacturer