

M7228 SERIES

DC/DC POWER SUPPLY



PRODUCT HIGHLIGHTS

- MINIATURE
- HIGH DENSITY
- SINGLE OUTPUT
- UP TO 200W
- DC/DC CONVERTER

Applications

Military (Airborne, ground-fix, shipboard), Ruggedized, Telecom, Industrial

Special Features

- Miniature size
- High efficiency
- Wide input range
- Input / Output isolation
- Remote sense
- External On/Off Inhibit
- Parallel connection with current share
- Redundancy connection
- Fixed switching frequency (250 kHz)
- External synchronization capability
- EMI/RFI filters included
- External output modification
- Indefinite short circuit protection with auto-recovery
- Over-voltage shutdown with auto-recovery
- Over temperature shutdown with auto-recovery

Electrical Specifications

DC Input:

DC Input range: 18 to 48 VDC, per MIL-STD-704E.

No damage for:

MIL-STD-1275A (100V for 50mSec)
MIL-STD-704A (80V for 0.1 Sec)

Line/Load regulation:

Less than 1% (no load to full load, -55°C to +85°C).

Ripple and Noise:

Less than 50mVp-p, typical (max. 1%) without external capacitance. When connected to system capacitance ripple drops significantly.

DC Output:

Output range – 2V to 15V
Output current – max 50A

Efficiency:

Typical 80-88% - (full load, room temperature)

Load Transient Overshoot and undershoot

Output resistance at load change of 50%-100% is 30-70 mΩ (depending on output voltage). Output back to steady stated within 300-500μSec

Isolation:

200V between Input and Output
200V between Input and Case
100V between Output and Case

EMI/RFI:

Design to meet* MIL-STD-461F
CE101, CE102, CS101, CS114, CS115, CS116, RE101, RE102, RS101, RS103

Turn on Transient

No voltage over shoot during power on.

M7228 SERIES DC/DC POWER SUPPLY

Protections *

Input

- **Inrush Current Limiter** – peak value of 5 x I_{in} for less than 50μSec.
- **Under voltage protection** – unit protects itself (no damage) below 16.5Vdc.
- **Over voltage protection** – unit protects itself (no damage) above 52Vdc

Output

- **Electronic over voltage protection** – Internal control protects unit (no damage) 10% above nominal voltage.
- **Passive transorb on outputs** – 20% above nominal voltage.
- **Current limiting** – Continuous protection (10-30% above maximum current) for unlimited time (Hiccup).

General

- Over temperature protection: Shutdown at base plate temperature of +105°C (±5°C) Automatic recovery at base plate temperature lower than +95°C (±5°C)

Environmental (Design to meet MIL-STD-810F)

Temperature:

Operating: -55°C to +85°C (base plate)

Storage: -55°C to +125°C

Humidity:

Method 507.4 - Up to 95%.

Altitude:

Method 500.4, Procedure I & II, 40,000 ft. and 70,000 ft. Operational

Vibration and Shock:

Shock - Saw-tooth, 20g peak, 11ms.
Vibration - Figure 514.5C-17.
General minimum integrity exposure. (1 hour per axis)

Salt Fog:

Method 509-4

Reliability

150,000 hours, calculated per MIL-STD-217F at +85°C base plate, Ground fixed.

Environmental Stress Screening (ESS)

Including random vibration and thermal cycles is also available. **Please consult factory for details.**

Pin Assignments

Pin No.	Pin Function
1	PAR OUT
2	-SIGNAL OUT RTN
3	-SENSE
4	-OUT
5	-OUT
6	-OUT
7	-OUT
8	-OUT
9	+OUT
10	+OUT

Pin No.	Pin Function
11	+OUT
12	+OUT
13	+OUT
14	SYN IN
15	SYN OUT
16	-SIGNAL IN RTN
17	+VIN
18	- VIN
19	- VIN
20	VCAL OUT

Pin No.	Pin Function
21	PAR IN
22	- OUT
23	-OUT
24	- OUT
25	- OUT
26	-OUT
27	+OUT
28	+OUT
29	+OUT
30	+OUT

Pin No.	Pin Function
31	+OUT
32	NC.
33	+SENSE
34	INHIBIT
35	+VIN
36	+VIN
37	- VIN

* All output parallel pins should be connected together for best performance.

Functions and Signals

INHIBIT signal

The INHIBIT signal is used to turn the power supply ON and OFF.

TTL “1” or OPEN – will turn on the power supply. (For normal operation leave the signal not connected.)

TTL “0” – will turn off the power supply.

SENSE

The SENSE is used to achieve accurate load regulations at load terminals (this is done by connecting the pins directly to the load’s terminals).

The use of remote sense has a limit of voltage dropout between converter’s output and load terminals of 2 – 10% of voltage output.

When not used connect +SENSE to +OUT and –SENSE to –OUT.

SYN IN signal

The SYN IN signal is used to allow the power supply frequency to sync with the system frequency.

The system frequency should be 250Khz \pm 10Khz TTL level.

When not connected the power supply will work at 250kHz.

SYN OUT signal

The SYNC OUT signal is used to sync the system with the power supply frequency.

PAR IN signal

The PAR IN signal is used to connect the power supply in parallel to other power supplies and have them divide equally the power between one another. All the power supplies should connect PAR IN signals together except the master unit where the PAR OUT signal connects to all the PAR IN signals.

PAR OUT signal

The PAR OUT signal is used to connect the power supply in parallel to other power supplies and have them divide equally the power between one another. The master unit connects the PAR OUT signals to all PAR IN pins of the slave units.

-SIGNAL IN RTN

The –SIGNAL IN is referred to the input ground.

This Pin is used as grounding for INHIBIT, SYN IN, SYN OUT signals.

-SIGNAL OUT RTN

The –OUT SIGNAL is referred to the output ground.

This Pin is used as grounding for PAR IN, PAR OUT and V/CAL OUT signal.

V/CAL OUT

The OUT V/CAL signal is used to control and adjust the output power of the power supply within the given tolerances.

Typical Connection

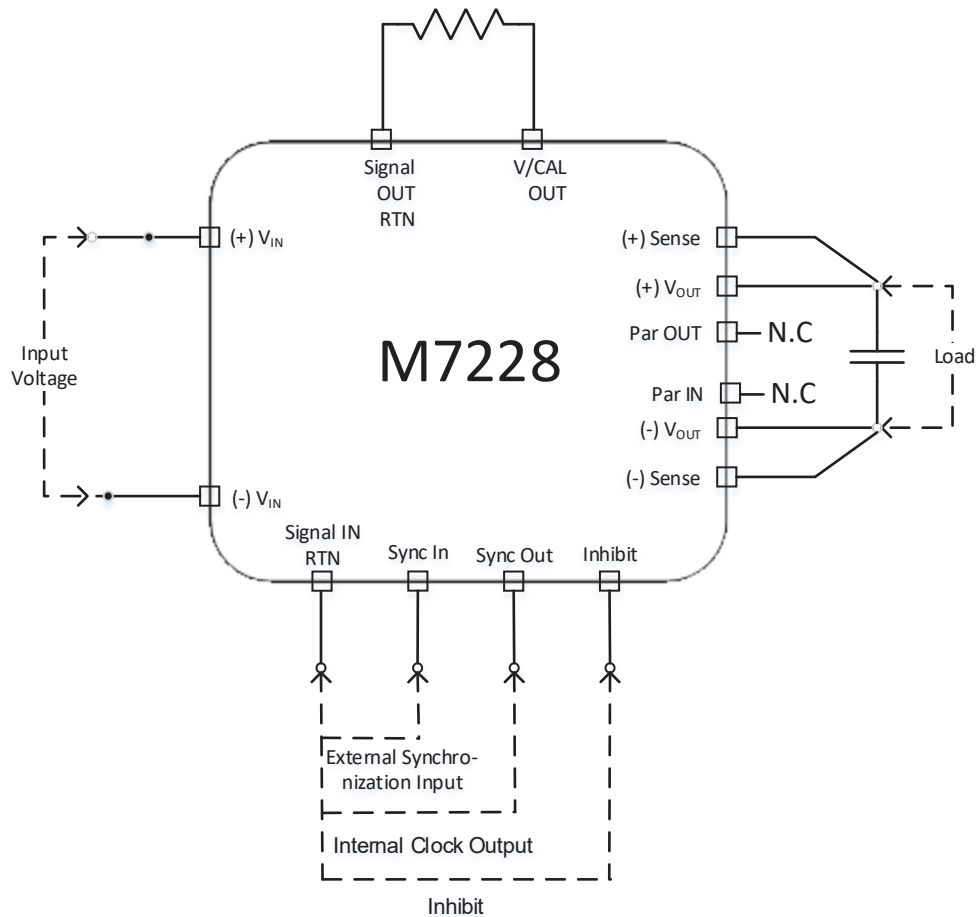

Parallel connection with current share

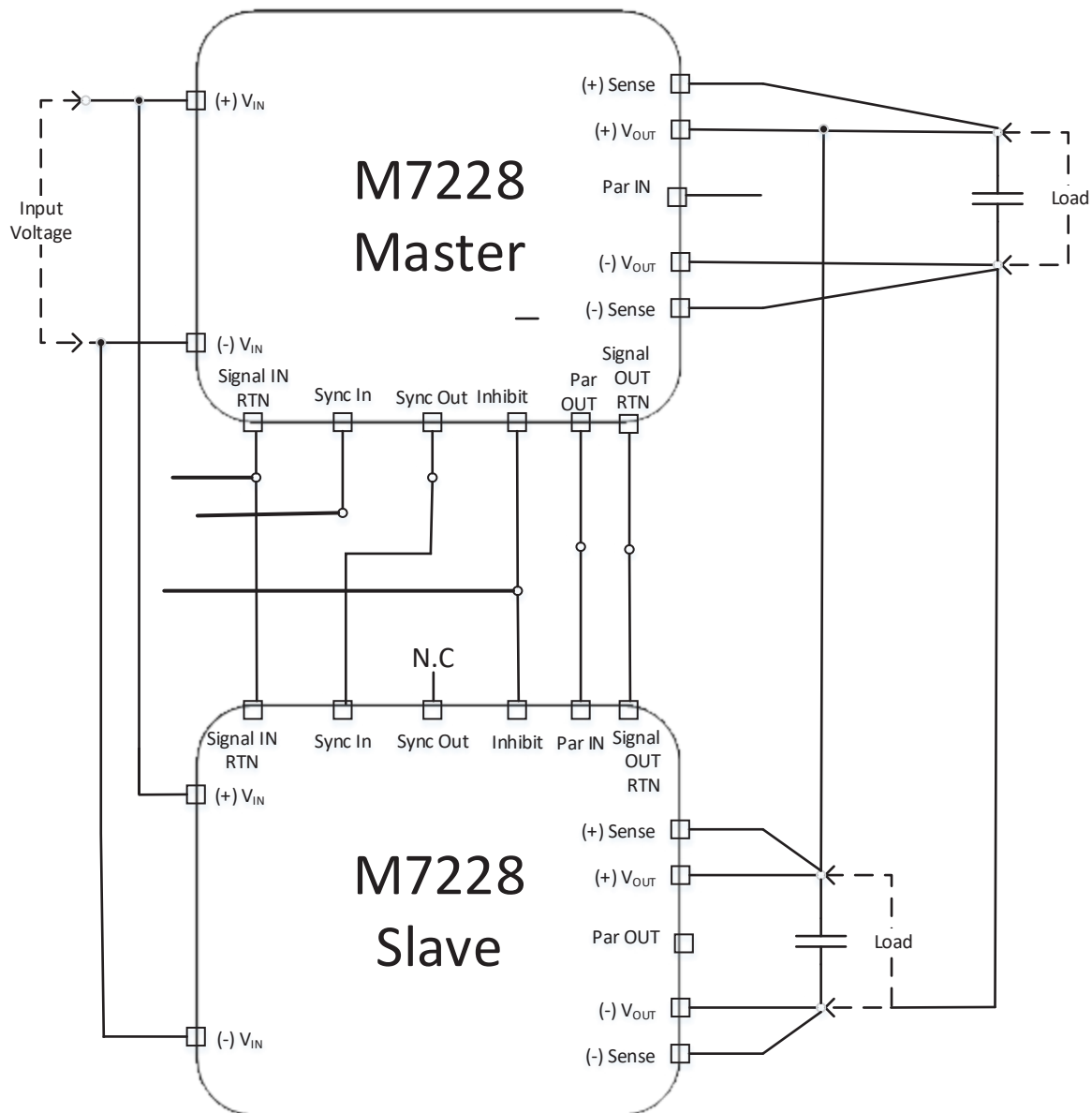

M7228 SERIES DC/DC POWER SUPPLY

Outline Drawing

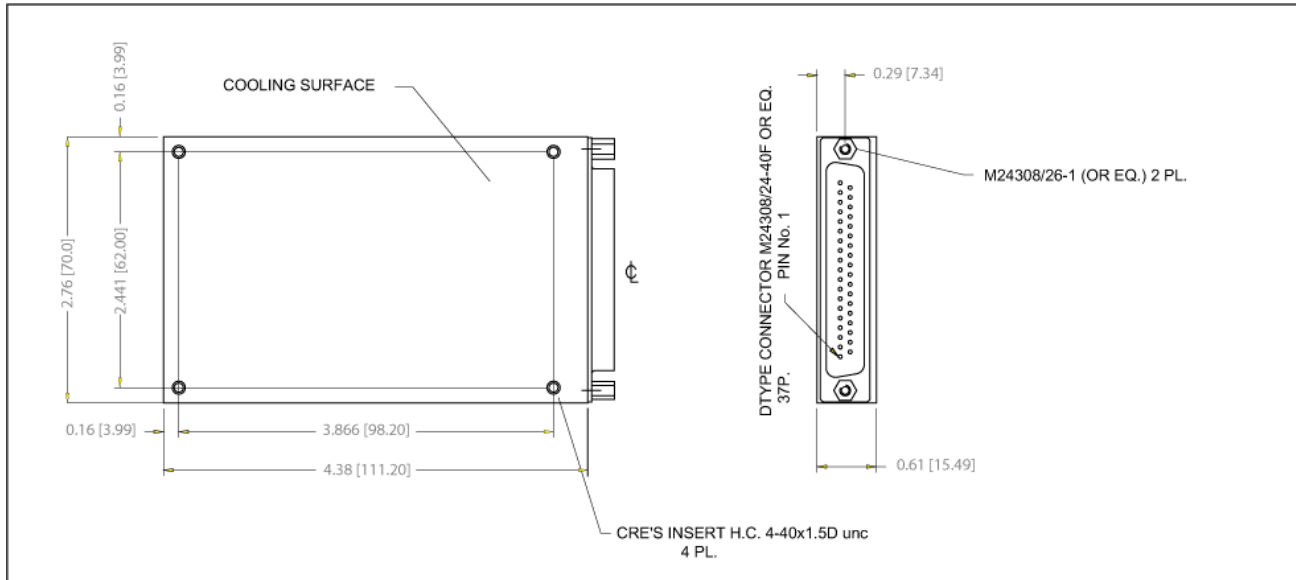

Heat Dissipation Surface

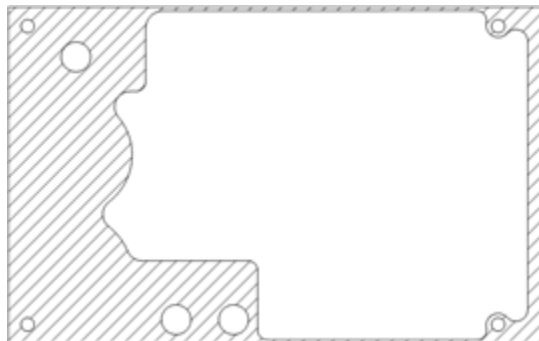

Dissipation Area 3.876 in ² (2501mm ²)

Notes

1. Dimensions are in Inches [mm]
2. Tolerance is:
 .XX ±.02 IN
 .XXX ±.01 IN
3. Weight: Approx. 265g (9.2 oz)
4. Mounting holes can be modified – please consult factory.
5. Parasolid 3D module is available for download on site.

* Specifications are subject to change without prior notice by the manufacturer