

M7318 SERIES

DC/DC POWER SUPPLY



PRODUCT HIGHLIGHTS

- MINIATURE
- HIGH DENSITY
- SINGLE OUTPUT
- DC/DC CONVERTER
- UP TO 200W

M7318 DC/DC POWER SUPPLY

Applications

Military (Airborne, ground-fix, shipboard), Ruggedized, Telecom, Industrial Power Supply

Special Features

- Wide input range
- Input / Output isolation
- High efficiency – up to 90%
- Over 40dB ripple rejection
- EMI filters included
- Remote sense compensation
- Current sharing available
- Fixed switching freq. (250 kHz)
- External sync. capability
- Remote inhibit (on/off)
- Non-latching protections:
 - Overload / short-circuit
 - Input OV/UV lockout
 - Output over-voltage
 - Over temperature

Electrical Specifications

DC Input

18 to 48 V_{DC}

Transient protection

IAW MIL-STD-1275A,
M-STD-704A

(no operation, no damage)

Output Voltage Regulation

Up to ±1% (no load to full load,
–55°C to +85°C, and over input
voltage range).

Ripple and Noise

Less than 100 mV_{p-p}, typical (max. 1%)
without external capacitance. When
connected to system capacitance
ripple drops significantly.

DC Output

Voltage range: 3.3 to 50 V_{DC}

Current range: 0 to 18 A

Power range: 0 to 200 W

Efficiency

Typical: 84% (at 28V_{DC} output,
nominal input, full load, room
temperature)

Transient Over-and-undershoot

Output change at load transient of 10
to 100% with T_r & T_f of max 30 μs is
less than 5% of output voltage.
Output recovers to steady stated
within less 0.1 ms, typically.

Isolation

Input to Output: 200 V_{DC}

Input to Case: 200 V_{DC}

Output to Case: 100 V_{DC}

EMC

Designed to meet MIL-STD-461F*
CE101, CE102, CS101, CS114, CS115,
CS116, RE101, RE102, RS101, RS103

Turn on Transient

No overshoot.

* Compliance achieved with 5μH LISN, shielded harness and static resistive load.

Protections[†]

Input

- **Under-Voltage Lock-Out:**
Unit shuts down below $16V \pm 1.5V$.
- **Over-Voltage Lock-Out:**
Unit shuts down above $52V \pm 2V$.

Output

- **Active Over-Voltage (Hiccup):**
Secondary control circuit takes over if output voltage exceeds $110\% \pm 5\%$ of nominal voltage. The output voltage go hiccup.
- **Passive Over-Voltage:**
Zener diode installed on output terminals, selected at $120\% \pm 10\%$ of nominal voltage.
- **Other forms of protection CV/CC, foldback**

General

- **Over Temperature Protection:**
Output shuts down if base plate temperature exceeds $+105^{\circ}C \pm 5^{\circ}C$. Automatic recovery when baseplate temperature returns to below $+95^{\circ}C \pm 5^{\circ}C$.

Environmental Conditions

Meets MIL-STD-810F

Temperature

Operating: $-55^{\circ}C$ to $+85^{\circ}C$ (at baseplate)
Storage: $-55^{\circ}C$ to $+125^{\circ}C$

Altitude

Method 500.4
Procedures I & II
Up to 70,000 ft. Operational

Salt Fog

Method 509.4

Humidity

Method 507.4
Procedure I
Up to 95% RH

Vibration (random)

Method 514.5
Category 24 – General minimum integrity exposure
IAW Figure 514.5C-17
1 hour per axis.

Shock

Method 516.5
Procedure I – Functional shock
Saw-tooth, 20 g peak, 11 ms

Reliability

150,000 hours, calculated per MIL-HDBK-217F Notice 2 at $+85^{\circ}C$ baseplate, Ground Fix conditions.

Environmental Stress Screening (ESS)

Including random vibration and thermal cycles is also available. **Please consult factory for details.**

[†] Thresholds and protections can be modified / removed – please consult factory.

Pin Assignment

Connector: RM272-030-322-2900 or eq.

Mating connector options (Other options available - consult factory):

- Solder cup sockets: RM242-030-241-5900 or eq.
- Removable crimp sockets: RM242-030-571-5900 or eq.

Pin #	Function	
1	OUTPUT	●
2	OUTPUT	●
3	OUTPUT	●
4	OUTPUT RTN	●
5	OUTPUT RTN	●
6	OUTPUT RTN	●
7	CURRENT SHARE	●
8	SENSE RTN	⊗
9	POWER GOOD	●
10	INPUT	●

Pin #	Function	
11	INPUT	●
12	INPUT RTN	●
13	INPUT RTN	●
14	SYNC OUT	●
15	SYNC IN	○
16	OUTPUT	●
17	OUTPUT	●
18	OUTPUT	●
19	OUTPUT RTN	●
20	OUTPUT RTN	●

Pin #	Function	
21	OUTPUT RTN	●
22	+SENSE	○
23	INPUT	●
24	INPUT	●
25	INPUT	●
26	INPUT RTN	●
27	INPUT RTN	●
28	INPUT RTN	●
29	INHIBIT	○
30	SIGNAL RTN	○

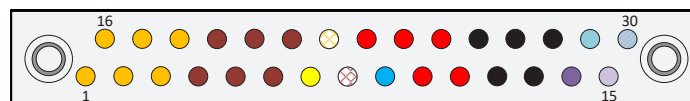

Note: All pins with identical function/designation should be connected together for optimal performance.

Functions and Signals

INHIBIT

The **INHIBIT** signal is used to turn the power supply ON and OFF.

To turn the power supply OFF, apply a TTL "0" signal or SHORT to **SIGNAL RTN**.

To turn the power supply ON, apply a TTL "1" signal or leave this pin OPEN.

If not used (always ON), leave this pin OPEN.

This signal is referenced to **SIGNAL RTN**.

SYNC IN

The **SYNC IN** signal is used to allow the power supply frequency to sync with the system frequency.

The system frequency should be 250 kHz \pm 10 kHz.

When not connected the power supply will work at 250 kHz \pm 10 kHz.

This signal is referenced to **SIGNAL RTN**.

SYNC OUT

The **SYNC OUT** signal can be used to synchronize the system to the power supply's clock.

This signal is referenced to **SIGNAL RTN**.

SIGNAL RTN

The **SIGNAL RTN** is referenced to **IN RETURN**.

This is used as grounding for **SYNC IN**, **INHIBIT** and **SYN OUT** signals.

SENSE

The SENSE is used to achieve accurate load regulations at load terminals (this is done by connecting the pins directly to the load's terminals).

For output voltage above 8V, the use of remote sense has a max limit of 0.25V voltage dropout between converter's output and load terminals.

For output voltage below 8V, the use of remote sense has a max limit of 0.5V voltage dropout between converter's output and load terminals.

When not used connect **SENSE** to **OUT** and **SENSE RTN** to **OUT RTN**.

CURRENT SHARE (Pin #7)

The **CURRENT SHARE** signal is used to connect the power supply in parallel to other power supplies and have them divide equally the power between one another.

Connect all **CURRENT SHARE** signals of all paralleled power supplies together.

This signal is referenced to **SENSE RTN** (pin #8).

POWER GOOD (Pin #9)

The VOLTS GOOD TTL signal is used to indicate if the output voltage is within the calibrated tolerances (typical 5%).

TTL "1" - output is within the required tolerances.

TTL "0" - output is not within the required tolerances.
This signal is referenced to **SENSE RTN** (pin #8).

Typical Connection Diagram

Parallel connection with current share

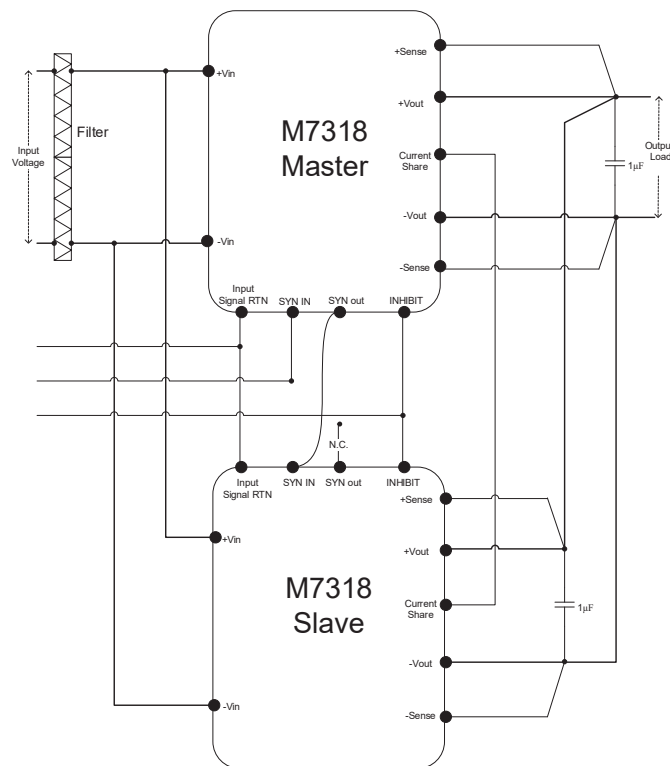

M7318 DC/DC POWER SUPPLY

Outline Drawing

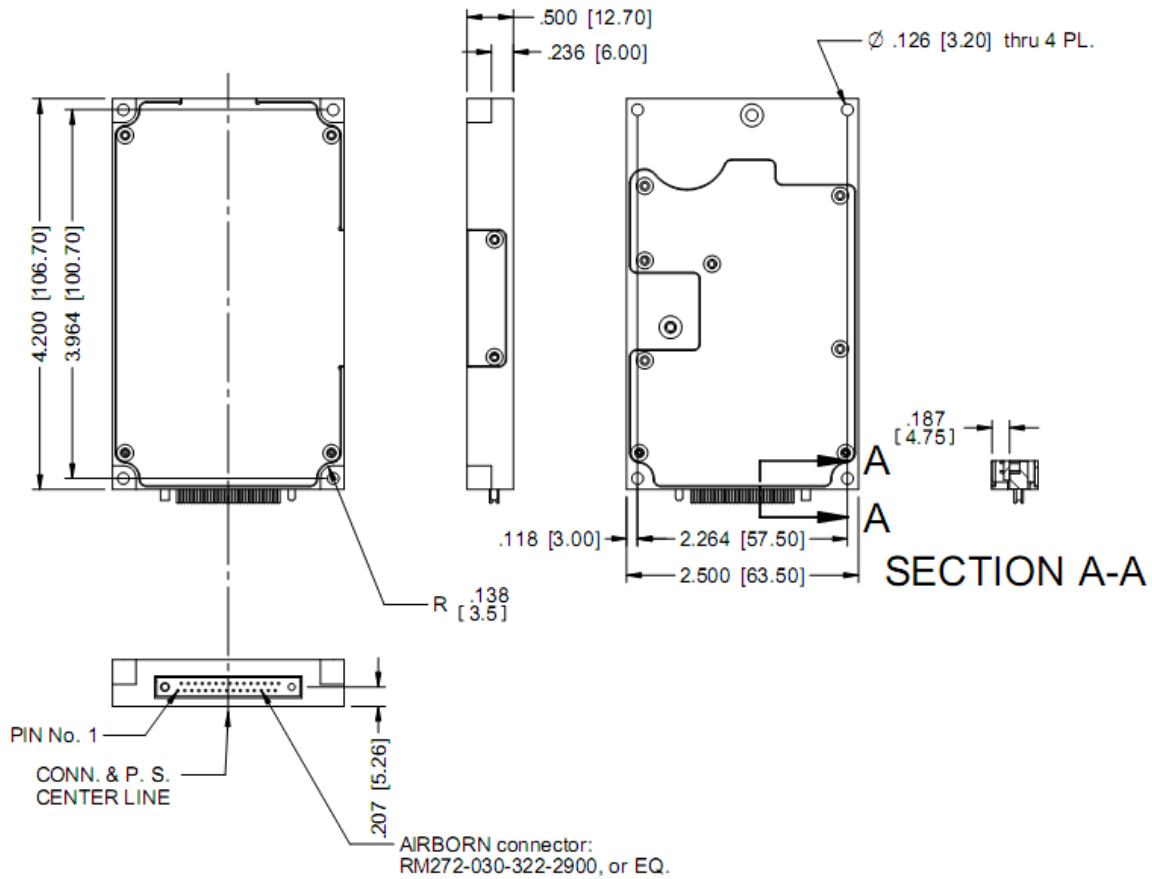

Heat Dissipation Surface

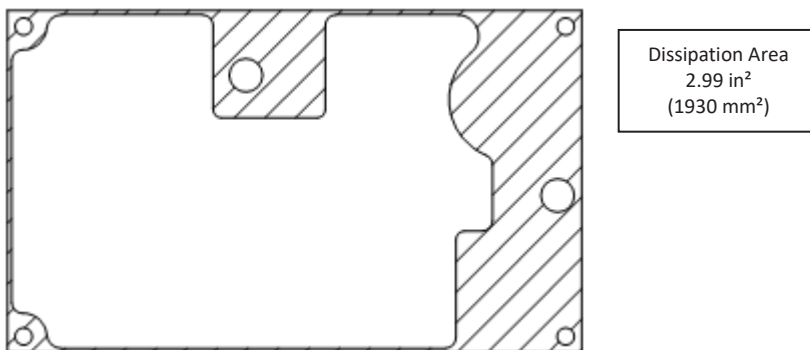

Notes

1. Dimensions are in Inches [mm]
2. Tolerance is:
.XX \pm .02 IN
.XXX \pm .01 IN
3. Weight: Approx. 150gr (5.3 Oz)

Standard Configurations

Part Number	Input	Output		Special features
	Voltage range	Voltage	Current	
M7318100	18 to 48 V _{DC}	5 V _{DC}	18 A	
M7318101	18 to 48 V _{DC}	12 V _{DC}	16 A	
M7318102	18 to 48 V _{DC}	15 V _{DC}	13A	
M7318103	18 to 48 V _{DC}	24 V _{DC}	8 A	
M7318104	18 to 48 V _{DC}	28 V _{DC}	7 A	
M7318105	18 to 48 V _{DC}	48 V _{DC}	4 A	
M7318800	18 to 48 V _{DC}	5 V _{DC}	18 A	<ul style="list-style-type: none"> • This Product is REACH Compliant • The aluminum parts comprising this converter are chromate conversion coated per MIL-DTL-5541F, Type II CLASS 1A or eq.
M7318801	18 to 48 V _{DC}	12 V _{DC}	16 A	
M7318802	18 to 48 V _{DC}	15 V _{DC}	13A	
M7318803	18 to 48 V _{DC}	24 V _{DC}	8 A	
M7318804	18 to 48 V _{DC}	28 V _{DC}	7 A	
M7318805	18 to 48 V _{DC}	48 V _{DC}	4 A	

Note: Specifications are subject to change without prior notice by the manufacturer