

# M7528 SERIES

## SINGLE-OUTPUT, 1000W DC TO DC BASEPLATE COOLED POWER SUPPLY

The M7528 is a series of mechanically robust, base-plate cooled, high performance, power supplies, designed for Airborne (MIL-STD-704), Ground Mobile (MIL-STD-1275) and other Hi-Reliability applications. The M7528 converts MIL-STD-704F and MIL-STD-1275E 28V power, to a well regulated, filtered and protected DC Output.



## M7528 Series– DC/DC Power Supply

**Standard Models List** (for other voltages – consult factory)

Part Number	Output		Power	Special features
	Voltage	Current		
M7528 101	12 V <sub>DC</sub>	50 A	600W	
M7528 102	15 V <sub>DC</sub>	50 A	750W	
M7528 103	24 V <sub>DC</sub>	42 A	1008W	
M7528 104	28 V <sub>DC</sub>	36 A	1008W	
M7528 105	48 V <sub>DC</sub>	20A	960W	
M7528 106	28 V <sub>DC</sub>	36A	1008W	Parallel operation via output voltage droop. Voltage regulation is ±2%.
M7528 107	48 V <sub>DC</sub>	20A	960W	Parallel operation via output voltage droop. Voltage regulation is ±2%.

- Additional standard configurations available. **Contact factory for more details.**
- All of our products can be configured to comply with EU REACH regulations. **Contact factory for more details.**
- Rides through transients IAW MIL-STD-1275E and MIL-STD-704F.

## M7528 Series– DC/DC Power Supply

### THE MAIN FEATURES OF THE M7528 ARE:

- DC/DC Single outputs power supply up to 1000W
- Standard Input version IAW MIL-STD-704F
- Standard Input version IAW MIL-STD-1275E
- Rides through transients IAW MIL-STD-1275E and MIL-STD-704F
- High efficiency – up to 88% (depending on output voltage).
- Full galvanic isolation between Input, Chassis and Outputs
- External Inhibit (On/Off)
- Fixed switching freq. (250 kHz)
- EMI filters included
- Remote sense compensation
- Indefinite short circuit protection with auto-recovery
- Over-voltage protection
- Over temperature shutdown with auto-recovery
- High density
- Conduction cooled via the baseplate

## M7528 Series— DC/DC Power Supply

### SPECIFICATIONS:

<b>DC Input</b>	<b>Voltage Range</b>	28VDC input IAW MIL-STD-704F and MIL-STD-1275E
	<b>Transients</b>	Rides through transients IAW MIL-STD-1275E and MIL-STD-704F: 12V, 1sec 16V, 30sec 18V Continuous 50V Continuous 100V, 50msec
	<b>Isolation</b>	Input to Output: 200 VDC Input to Case: 200 VDC
	<b>Input Reverse Polarity</b>	Protection for unlimited time
	<b>Under-Voltage Lock-Out</b>	Unit shuts down when input voltage falls below 10.5VDC ±1VDC <b>Please consult factory for more details.</b>
	<b>Over-Voltage Lock-Out</b>	Unit shuts down when input voltage rises above $104V_{DC} \pm 2V_{DC}$ <b>Please consult factory for more details.</b>
	<b>DC Output</b>	<b>Rating</b>
<b>Voltage Regulation</b>		Better than or equal to ±1% (low to high line voltage, no load to full load, -55 °C to +85 °C at baseplate).
<b>Remote Sense</b>		<u>Description:</u> Used to achieve accurate voltage regulation at load terminals, to compensate for voltage drop across the leads connecting the converter to the load, 0.25 V ± 0.1 V <u>Use:</u> Connect SENSE line directly to the load's positive terminal, and SENSE RTN directly to the load's negative terminal. If not used, connect SENSE to OUTPUT and SENSE RTN to OUTPUT RTN. Do not leave open!
<b>Ripple</b>		Less than 50mV <sub>p-p</sub> , typical (max. 1%) without external capacitance. When connected to system capacitance ripple drops significantly.
<b>Isolation</b>		Output to Case: 100 VDC

**M7528 Series– DC/DC Power Supply**

	<b><i>Overvoltage Protection</i></b>	<ul style="list-style-type: none"> <li>• <b>Active Over-Voltage Protection:</b> The secondary control circuit takes the over if output voltage exceeds <math>110\% \pm 5\%</math> of nominal voltage. Beyond this, output voltage clamps.</li> <li>• <b>Passive Over-Voltage Protection:</b> Zener diode installed on output terminals, selected at <math>120\% \pm 10\%</math> of nominal voltage.</li> </ul>
	<b><i>Efficiency</i></b>	<p>For 18 to 48Vdc input with 28V/36A output: 88-89% typical            For 12-100Vdc input with 28V/36A output: 85% typical</p>
	<b><i>Current Limit &amp; Overload</i></b>	<p>Output voltage turns off and on periodically with low duty cycle (hiccup) to protect system conductors and converter from short circuit</p>
	<b><i>Over Temp. Protection</i></b>	<p>Output shuts down if base plate temperature exceeds <math>+105^{\circ}\text{C} \pm 5^{\circ}\text{C}</math>. Automatic recovery when baseplate temperature returns to below <math>+95^{\circ}\text{C} \pm 5^{\circ}\text{C}</math>.</p>

## M7528 Series– DC/DC Power Supply

### Specifications (Cont.):

<b>Control &amp; Indication</b>	<b><i>INHIBIT Signal</i></b>	<p><u>Description:</u> Inhibits output.  <u>Use:</u> Apply short circuit or TTL "LOW" to turn off the power supply.            Leave open or apply TTL "HIGH" to turn on the power supply.  <u>Referenced to:</u> SIGNAL RTN</p>
	<b><i>SYNC</i></b>	<p><u>Description:</u> Synchronizes internal switching frequency to system clock. <u>Use:</u> Apply TTL level, 250 kHz ± 10 kHz, 50% duty-cycle clock.            Leave open if unused. In this case, the switching frequency will be set by the internal clock (250 kHz)  <u>Referenced to:</u> SIGNAL RTN</p>
	<b><i>SIGNAL RTN</i></b>	<p><u>Description:</u> Signals return reference.  <u>Referenced to:</u> Connected by a 100 Ω resistor to INPUT RTN</p>
	<b><i>POR Optional</i></b>	<p><u>Description:</u> The <b>POR</b> signal disables the input under voltage lockout, input over voltage lockout, over temperature protection and peak load duration limiter.  <b>Please consult factory for details.</b></p>
<b>Environment Designed to meet MIL-STD-810F</b>	<b><i>Temperature</i></b>	<p>Methods 501.4 &amp; 502.4            Operating: –55 °C to +85 °C (at baseplate)            Storage: –55 °C to +125 °C (ambient)</p>
	<b><i>Humidity</i></b>	<p>Method 507.4            Up to 95% RH</p>
	<b><i>Salt-fog</i></b>	<p>Method 509.4</p>
	<b><i>Altitude</i></b>	<p>Method 500.4            Procedures I – Storage/Air transport:            up to 70,000 ft. (non-operational)            Procedure II – Operation/Air Carriage:            up to 70,000 ft. (operational)</p>
	<b><i>Mechanical Shock</i></b>	<p>Method 516.5            Procedure I            30 g / 11 ms terminal peak saw-tooth</p>
	<b><i>Vibration</i></b>	<p>Method 514.5            Category 4 - General minimum integrity exposure            IAW Figure 514.5C-17            1 hour per axis.</p>
<b><i>Fungus</i></b>	<p>Does not support fungus growth, in accordance with the guidelines of MIL-STD-454, Requirement 4-</p>	

## M7528 Series– DC/DC Power Supply

<b>EMI</b>	<i>MIL-STD-461F</i>	Designed to meets* MIL-STD-461F CE101, CE102, CS101, CS114, CS115, CS116, RE101, RE102, RS101, RS103 *EMI Compliance achieved with 5μH LISN, shielded harness and static resistive load.
<b>Reliability</b>	150,000 hours, calculated per MIL-HDBK-217F Notice 2 at +85 °C baseplate, Ground Fix conditions.	
<b>Cooling Requirements</b>	The M7528 is a baseplate cooled unit. The base of the M7528 should be thermally attached to a suitable heatsink that maintains it below +85 °C.	
<b>Form factor</b>	4.76" wide, 1.29" high and 6.40" deep. For detailed dimensions and tolerances see Drawing: TBD.	
<b>Weight</b>	Approx. 1100 g.	
<b>Connectors</b>	<p><b>Input connector</b> - J1 Connector type: M24308/24-40F or eq <b>Mates with:</b> M24308/2-4F or eq.</p> <p><b>Output connector</b> – J2 Connector type: M24308/23-39F or eq <b>Mates with:</b> M24308/4-3F or eq.</p>	

## M7528 Series– DC/DC Power Supply

Vin 28V

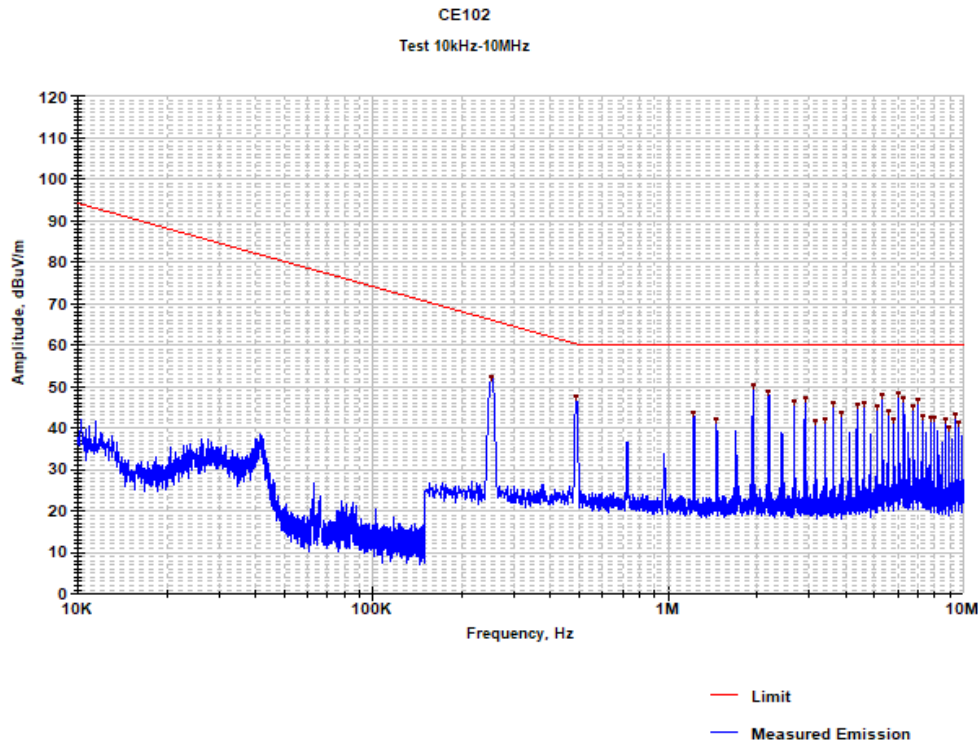

Frequency (MHz)	Measured Emission (dBuV/m)	Limit (dBuV/m)	Delta (dB)
1.938	50.1	60.0	-9.9
2.191	48.7	60.0	-11.3
5.323	48.0	60.0	-12.0
6.041	48.2	60.0	-11.8

## M7528 Series– DC/DC Power Supply

Vin 28V RTN

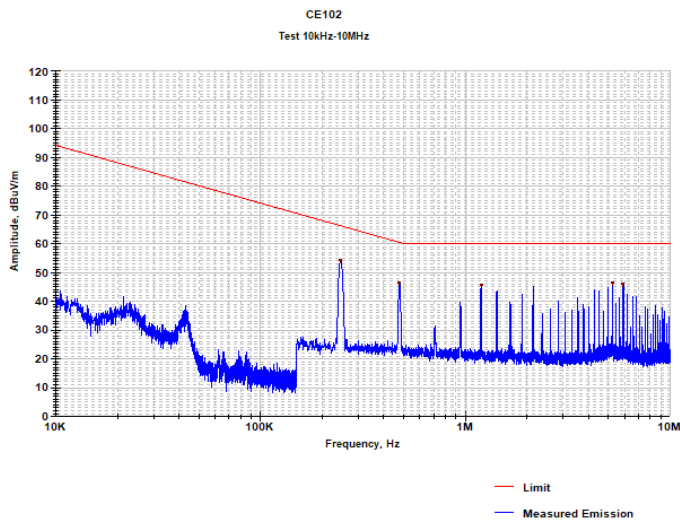

Frequency (MHz)	Measured Emission (dBuV/m)	Limit (dBuV/m)	Delta (dB)
0.247	54.0	66.1	-12.2
0.477	46.2	60.4	-14.2
1.195	45.3	60.0	-14.7
5.207	46.3	60.0	-13.7
5.904	45.9	60.0	-14.1

## M7528 Series– DC/DC Power Supply

### RE 102 2-30 MHz TEST

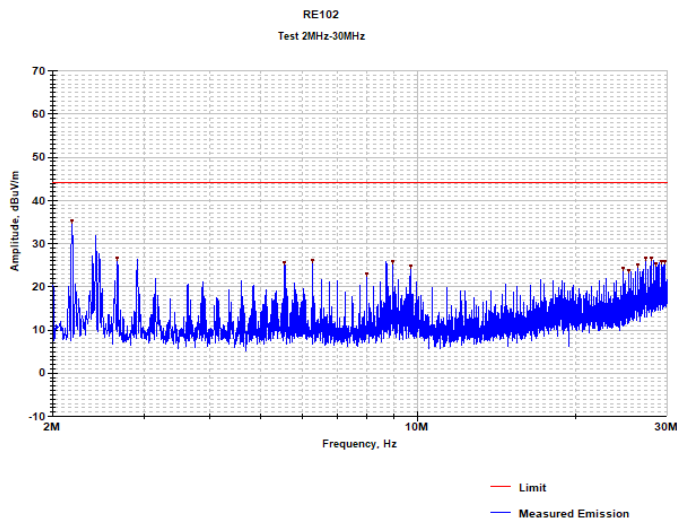

Frequency (MHz)	Measured Emission (dBuV/m)	Limit (dBuV/m)	Delta (dB)
2.179	35.2	44.0	-8.8
2.661	26.5	44.0	-17.5
5.562	25.6	44.0	-18.4
6.290	26.1	44.0	-17.9
7.981	23.1	44.0	-20.9
8.944	25.8	44.0	-18.2
9.672	24.8	44.0	-19.2
24.652	24.3	44.0	-19.7

## M7528 Series– DC/DC Power Supply

<b>25.374</b>	<b>23.6</b>	<b>44.0</b>	<b>-20.4</b>
<b>26.343</b>	<b>24.9</b>	<b>44.0</b>	<b>-19.1</b>
<b>27.306</b>	<b>26.5</b>	<b>44.0</b>	<b>-17.5</b>
<b>28.034</b>	<b>26.7</b>	<b>44.0</b>	<b>-17.3</b>
<b>28.516</b>	<b>25.4</b>	<b>44.0</b>	<b>-18.6</b>
<b>29.238</b>	<b>25.7</b>	<b>44.0</b>	<b>-18.3</b>
<b>29.720</b>	<b>25.8</b>	<b>44.0</b>	<b>-18.2</b>

### 30-200MHz

#### Test horizontal

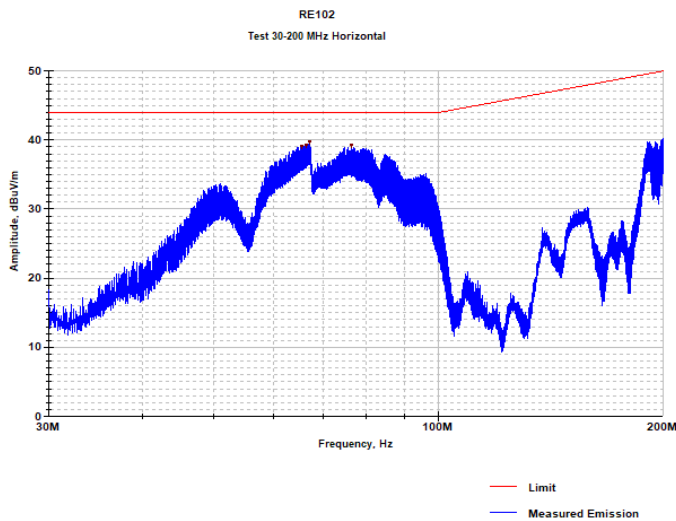

<b>Frequency (MHz)</b>	<b>Measured Emission (dBuV/m)</b>	<b>Limit (dBuV/m)</b>	<b>Delta (dB)</b>
<b>65.462</b>	<b>39.1</b>	<b>44.0</b>	<b>-4.9</b>
<b>66.414</b>	<b>39.3</b>	<b>44.0</b>	<b>-4.7</b>

## M7528 Series– DC/DC Power Supply

<b>67.128</b>	<b>39.7</b>	<b>44.0</b>	<b>-4.3</b>
<b>76.291</b>	<b>39.3</b>	<b>44.0</b>	<b>-4.7</b>

### Test vertical

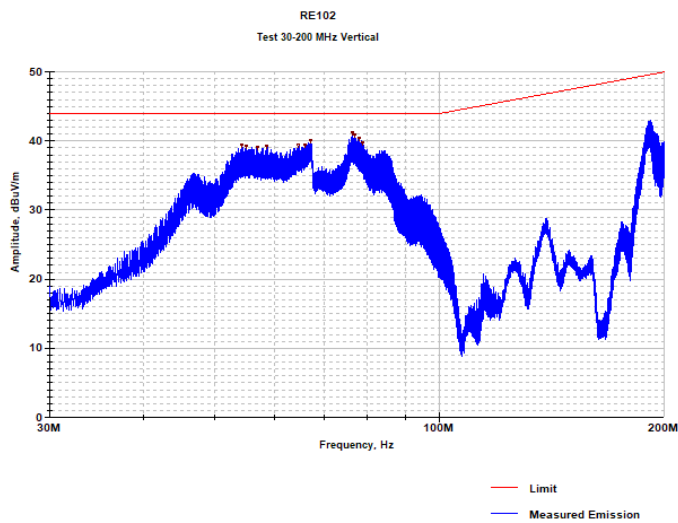

Frequency (MHz)	Measured Emission (dBuV/m)	Limit (dBuV/m)	Delta (dB)
<b>65.462</b>	<b>39.1</b>	<b>44.0</b>	<b>-4.9</b>
<b>66.414</b>	<b>39.3</b>	<b>44.0</b>	<b>-4.7</b>
<b>67.128</b>	<b>39.7</b>	<b>44.0</b>	<b>-4.3</b>
<b>76.291</b>	<b>39.3</b>	<b>44.0</b>	<b>-4.7</b>

## M7528 Series– DC/DC Power Supply

200MHz-1000MHz

Test horizontal

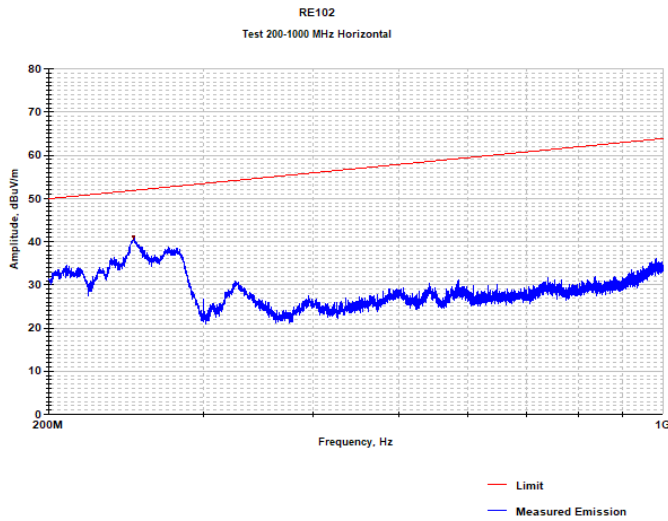

Frequency (MHz)	Measured Emission (dBuV/m)	Limit (dBuV/m)	Delta (dB)
249.760	41.13	51.93	-10.80

## M7528 Series– DC/DC Power Supply

### Test vertical

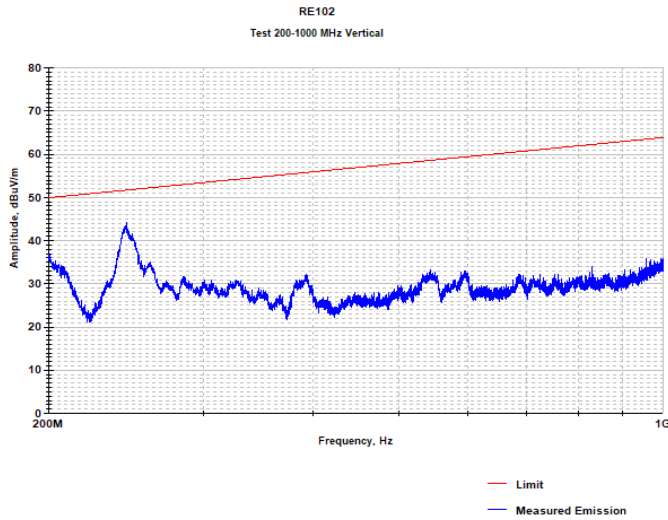

Frequency (MHz)	Measured Emission (dBuV/m)	Limit (dBuV/m)	Delta (dB)
245.280	44.07	51.78	-7.71

1000MHz-18GHz

Test horizontal

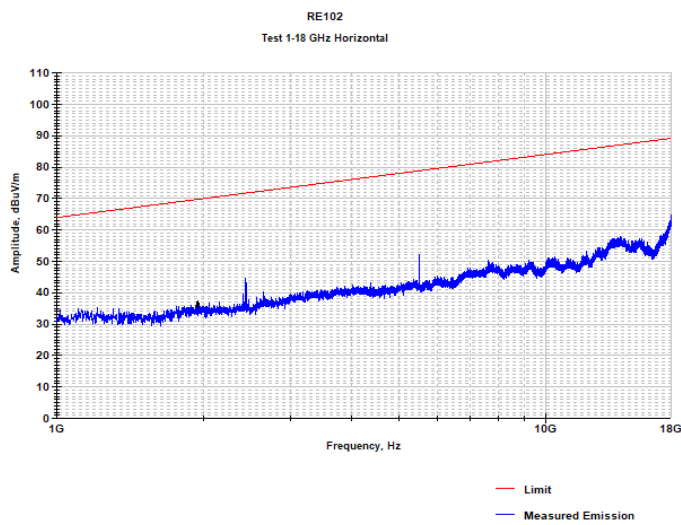

M7528 Series– DC/DC Power Supply

Test vertical

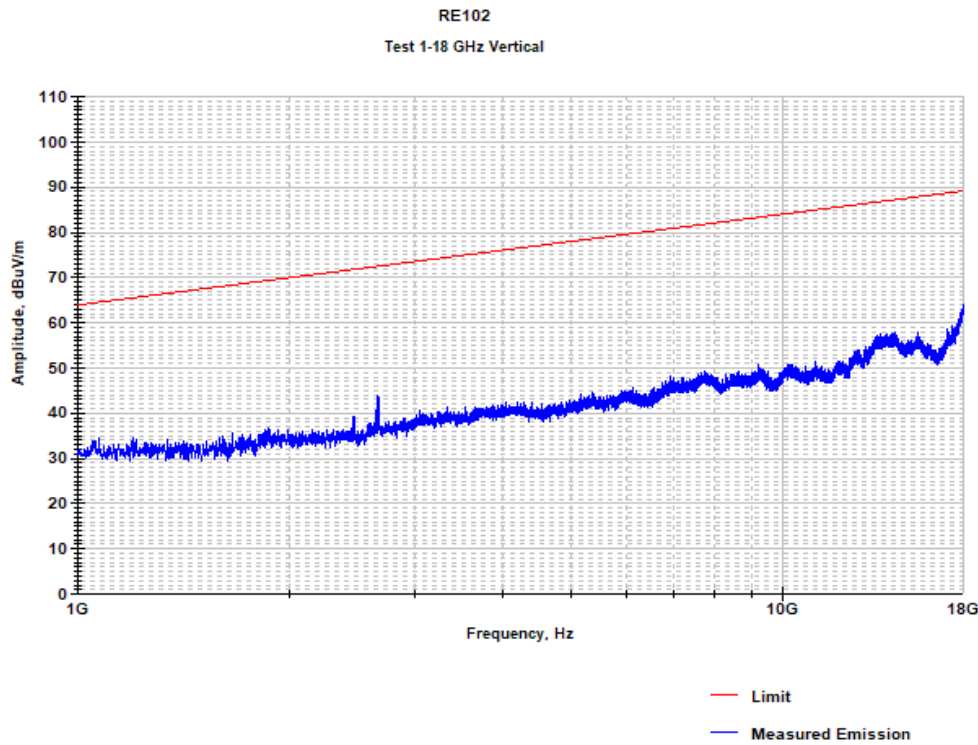

**M7528 Series— DC/DC Power Supply**

**TYPICAL CONNECTION DIAGRAM**

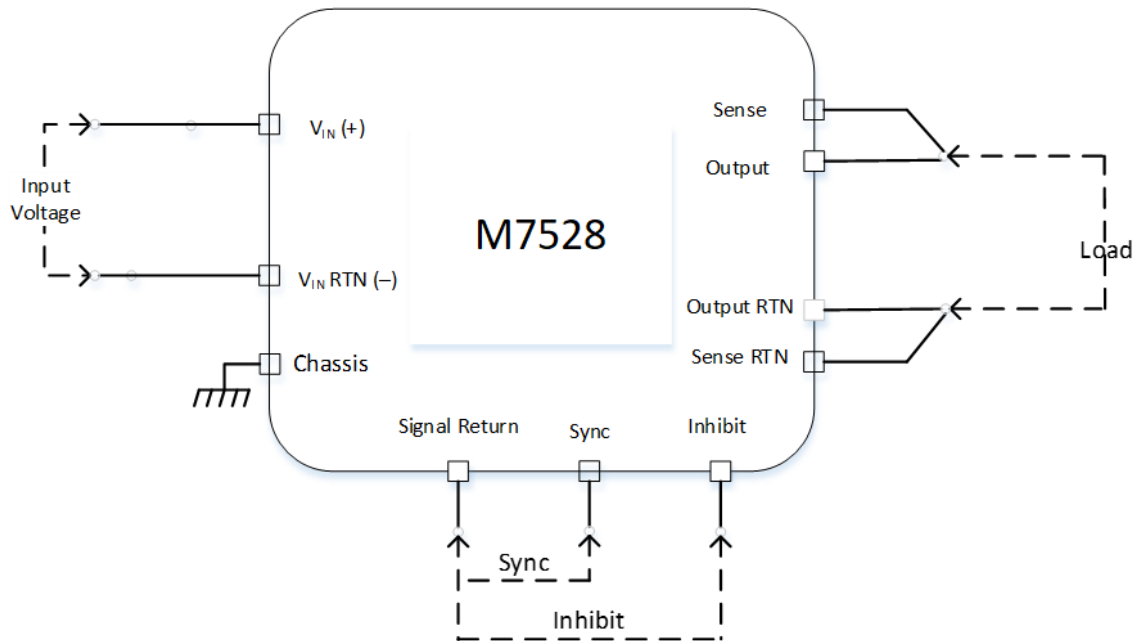

**M7528 Series– DC/DC Power Supply**

**PARALLEL CONNECTION DIAGRAM**

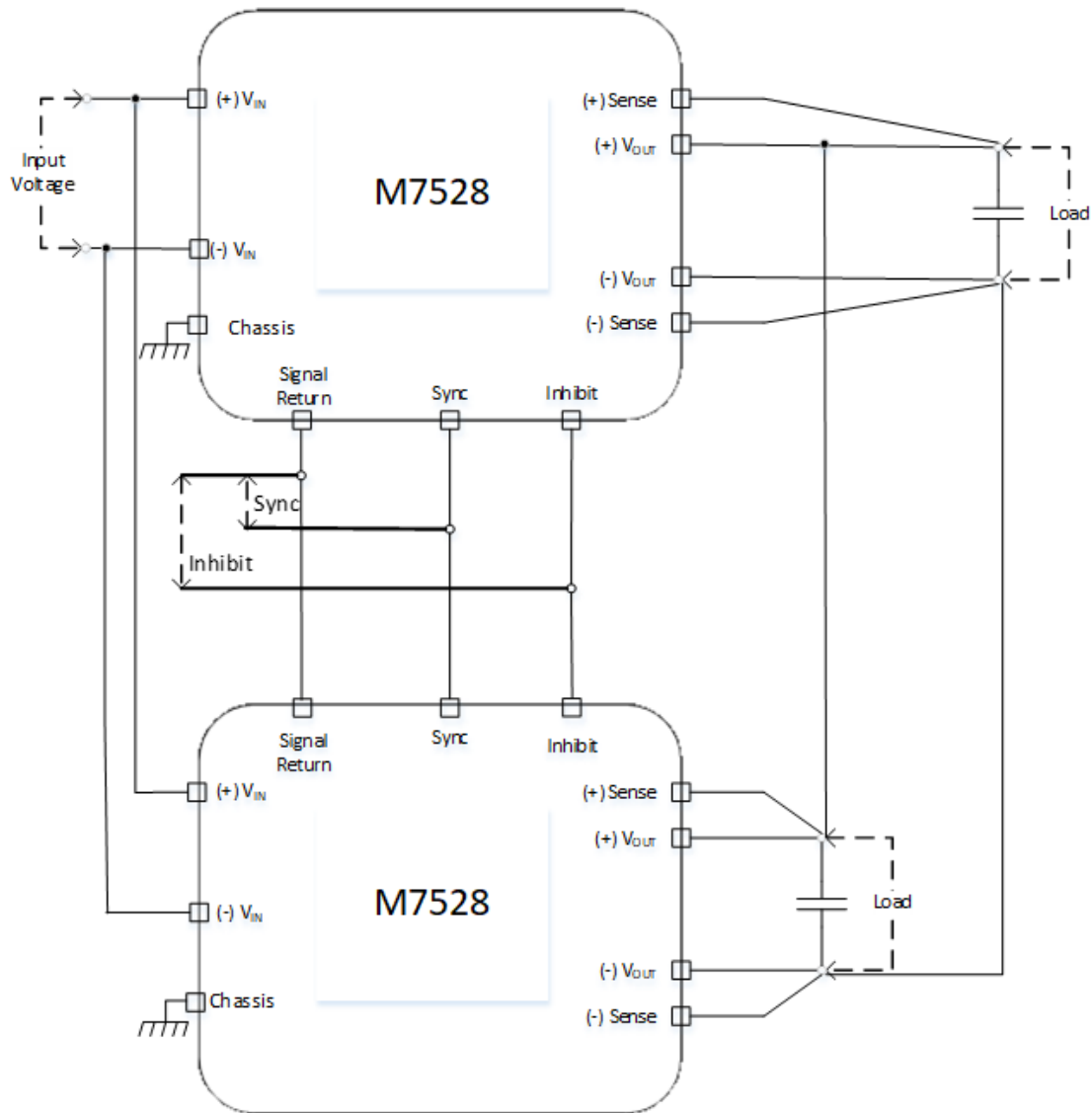

**Note:** Parallel operation via output voltage droop. Voltage regulation is  $\pm 2\%$ .

## M7528 Series– DC/DC Power Supply

### PIN ASSIGNMENT:

**Input connector** - J1 Connector type: M24308/24-40F or eq

**Mates with:** M24308/2-4F or eq.

Pin No.	Function	P	Pin No.	Function	P	Pin No.	Function	P
1	INPUT	+	14	INPUT RTN	-	27	INPUT	+
2	INPUT	+	15	INPUT RTN	-	28	INPUT RTN	-
3	INPUT	+	16	INPUT RTN	-	29	INPUT RTN	-
4	INPUT	+	17	N.C.		30	INPUT RTN	-
5	INPUT	+	18	INHIBIT	+	31	INPUT RTN	-
6	INPUT	+	19	SYNC	+	32	INPUT RTN	-
7	INPUT	+	20	INPUT	+	33	INPUT RTN	-
8	INPUT	+	21	INPUT	+	34	INPUT RTN	-
9	INPUT RTN	-	22	INPUT	+	35	INPUT RTN	-
10	INPUT RTN	-	23	INPUT	+	36	CHASSIS	
11	INPUT RTN	-	24	INPUT	+	37	SIGNAL RTN	-
12	INPUT RTN	-	25	INPUT	+			
13	INPUT RTN	-	26	INPUT	+			

**Output connector** – J2 Connector type: M24308/23-39F or eq.

**Mates with:** M24308/4-3F or eq.

Pin No.	Function	P	Pin No.	Function	P	Pin No.	Function	P
1	SENSE	+	10	OUTPUT RTN	-	19	OUTPUT	+
2	OUTPUT	+	11	OUTPUT RTN	-	20	OUTPUT RTN	-
3	OUTPUT	+	12	OUTPUT RTN	-	21	OUTPUT RTN	-
4	OUTPUT	+	13	SENSE RTN	-	22	OUTPUT RTN	-
5	OUTPUT	+	14	OUTPUT	+	23	OUTPUT RTN	-
6	OUTPUT	+	15	OUTPUT	+	24	OUTPUT RTN	-
7	N.C.		16	OUTPUT	+	25	OUTPUT RTN	-
8	OUTPUT RTN	-	17	OUTPUT	+			
9	OUTPUT RTN	-	18	OUTPUT	+			

Note: All pins with identical function/designation should be connected together for optimal performance.

## M7528 Series— DC/DC Power Supply

### OUTLINE DRAWING:

For detailed dimensions and tolerances see Drawing: M7528001

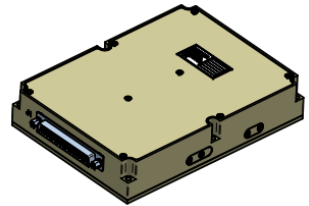
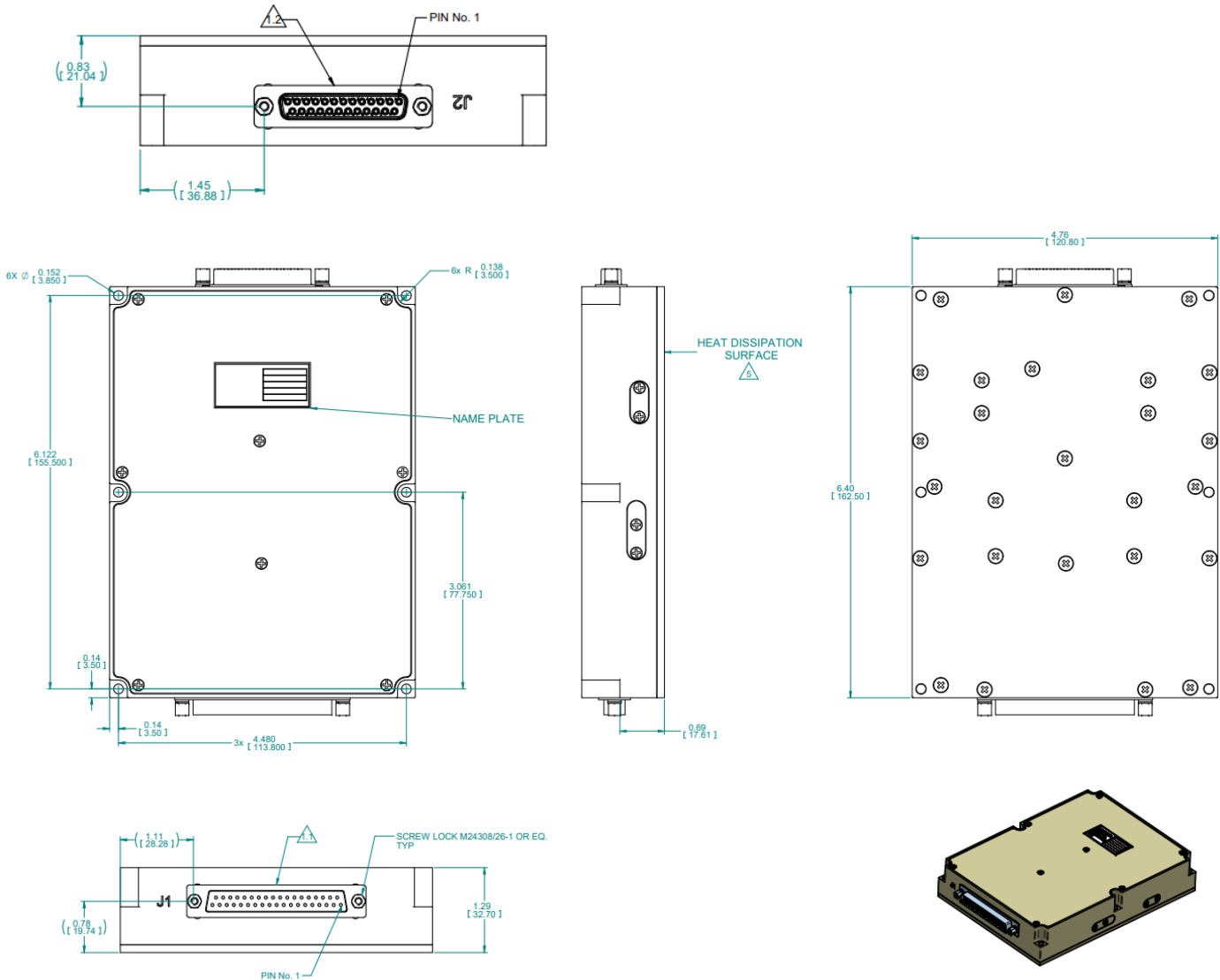

#### NOTES :

- CONNECTORS:
  - 1.1 - INPUT PLUG D-TYPE CONN. 37P, P/N: M24308/24-40F OR EQ.
  - 1.2 - OUTPUT SOCKET D-TYPE CONN. 25P, P/N: M24308/23-39F OR EQ.
- WORKMANSHIP SHALL BE MIL-STD-454, REQT. 9
- MTL. AL 6061-T651& AL 5052-H32
- CHROMATE CONVERSION COATING PER MIL -DTL-5541F, TYPE 1 CLASS 1A
- HEAT DISSIPATION SURFACE: 30.43 in<sup>2</sup> [19,630 mm<sup>2</sup>]
- ENGRAVING:
  - CHARACTERS HEIGHT: 0.157in [4mm] DEPTH: 0.157in [4mm].
  - FILL ENGRAVING WITH BLACK LUSTERLESS EPOXY PAINT COLOR PER FED-STD 595 NO : 37038.

DIMENSIONS ARE IN INCH [MM]  
DO NOT SCALE DRAWING

GENERAL TOLERANCES  
X.XX ±.02 [0.50]  
X.XXX ±.006 [0.15]  
ANGLES ±1°

Note: Specifications are subject to change without prior notice by the manufacturer.