

M8053 SERIES

DC/DC POWER SUPPLY



PRODUCT HIGHLIGHTS

- MINIATURE
- HIGH DENSITY
- WIDE INPUT RANGE
- DUAL OUTPUT
- DC/DC CONVERTER
- UP TO 125W

APPLICATIONS

Military, Ruggedized, Telecom, Industrial

SPECIAL FEATURES

- Miniature size
- High efficiency
- Wide input range
- Up to 20 W/in³
- Input / Output isolation
- Fixed switching frequency (250 kHz)
- TTL logic enable
- EMI filters included
- Indefinite short circuit protection with auto-recovery
- Input over-voltage shutdown with auto-recovery
- Over temperature shutdown with auto-recovery

ENVIRONMENTAL

Meets or exceeds MIL-STD-810D

Temperature:

Operating: -55 °C to +85 °C (baseplate)

Storage: -55 °C to +125 °C (ambient)

RELIABILITY

150,000 hours, calculated per MIL-STD-217F

Notice 2 at +85 °C baseplate, ground fixed.

ELECTRICAL SPECIFICATIONS

DC INPUT

DC Input range: 18 to 70 V_{DC}

Input transient protection:

All models meet or exceed (no damage)

MIL-STD-1275A (100 V for 50 ms) and

MIL-STD-704A (80 V for 0.1 s)

Efficiency: up to 80%

EMC:

Designed to meet MIL-STD-461F*

CE101, CE102, CS101, CS114, CS115, CS116, RE101,

RE102, RS101, RS103

Isolation:

Input to Output: 200 V_{DC}

Input to Case: 200 V_{DC}

DC OUTPUTS (floating)

Line/Load regulation: Less than ±1%
(no load to full load, -55 °C to +90 °C)

Ripple and Noise: 50 mV_{p-p}, typical (max. 1%)

Current limiting (Hiccup):

Continuous protection for unlimited time

Over voltage protection:

Passive transorb on outputs.

Over temperature protection:

Shutdown at baseplate temperature of +105 °C ± 5 °C.

Automatic recovery at baseplate temperature lower than +95 °C ± 5 °C.

Isolation: Output to Case: 100V_{DC}

* Compliance achieved with 5μH LISN, shielded harness and static resistive load.

PIN ASSIGNMENT

Connector type: 30 pin connector M55302/61-A30 with fixed threaded jackset or eq. (Add suffix SL to specify connector with guideset per M55302/57-A30X)

Mates with: WTAX 30 SAC JT# (solder cup contacts, turning jackset) or WTDXA 30 S JT# (crimp removeable #22 AWG contacts, turning jackset) or eq. (replace # with a letter for the required hardware type).

Pin No.	Pin Function	Pin No.	Pin Function	Pin No.	Pin Function
1	OUT 1 (+)	11	SIGNAL RTN	21	OUT 2 (+)
2	OUT 1 (+)	12	VIN RTN (-)	22	OUT 2 RTN (-)
3	OUT 1 RTN (-)	13	VIN RTN (-)	23	OUT 2 RTN (-)
4	OUT 1 RTN (-)	14	VIN (+)	24	N.C.
5	OUT 2 (+)	15	VIN (+)	25	INHIBIT
6	OUT 2 (+)	16	OUT 1 (+)	26	VIN RTN (-)
7	OUT 2 RTN (-)	17	OUT 1 (+)	27	VIN RTN (-)
8	OUT 2 RTN (-)	18	OUT 1 RTN (-)	28	VIN (+)
9	N.C.	19	OUT 1 RTN (-)	29	VIN (+)
10	N.C.	20	OUT 2 (+)	30	SYNC

Note: All pins with identical function should be connected together for best performance and reliability.

FUNCTIONS AND SIGNALS

INHIBIT signal

The **INHIBIT** signal is used to turn the power supply ON and OFF.

TTL "1" or OPEN – will turn on the power supply (For normal operation leave this signal unconnected).

TTL "0" or short– will turn off the power supply. This signal is referenced to the **SIGNAL RTN**.

SYNC signal

The **SYNC** signal is used to allow the power supply frequency to sync with the system frequency.

The system frequency should be 250 kHz ± 10 kHz.

When not connected the power supply will work at 250 kHz ± 10 kHz.

This signal is referenced to the **SIGNAL RTN**.

SIGNAL RTN

The **SIGNAL RTN** is used as grounding for all signals. This pin is referenced to the **VIN RTN**.

OUTLINE DRAWING

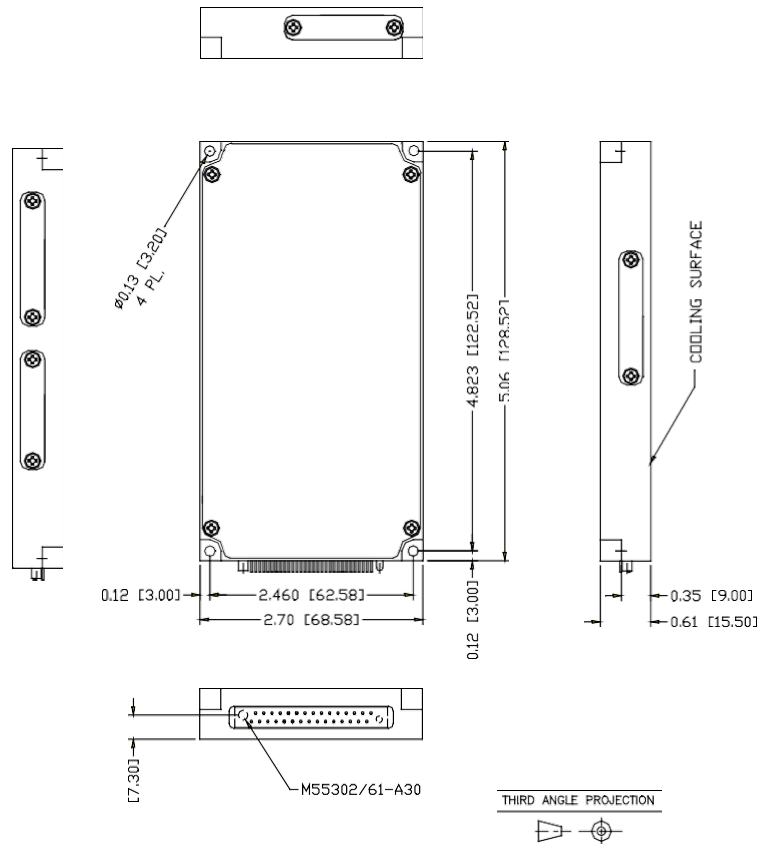

Notes

1. Dimensions are in inches [mm]
2. Tolerance is:
 .XX \pm 0.02 in
 .XXX \pm 0.01 in
3. Weight: 9.55 oz [270.5 g]

M8053 SERIES DC/DC POWER SUPPLY

Standard Models List (for other voltages/current – consult factory)

Part Number	Input	Output 1		Output 2		Power	Special features
	Voltage range	Voltage	Current	Voltage	Current		
M8053100	18-70Vdc	3.3V _{DC}	10 A	5V	10A	83W	
M8053101	18-70Vdc	5 V _{DC}	10 A	12V	5A	110W	
M8053102	18-70Vdc	12 V _{DC}	5 A	3.3V	10A	93W	
M8053103	18-70Vdc	24 V _{DC}	2.5 A	5V	10A	110W	
M8053104	18-70Vdc	28 V _{DC}	2.5A	5V	10A	120W	
M8053105	18-70Vdc	28 V _{DC}	2.5A	12V	4.5A	124W	

- Additional standard configurations available. **Contact factory for more details.**
All of our products can be configured to comply with EU REACH regulations. **Contact factory for more details**

Note: Specifications are subject to change without prior notice by the manufacturer