

M8187

2 KW DC/ DC BASEPLATE COOLED POWER SUPPLY

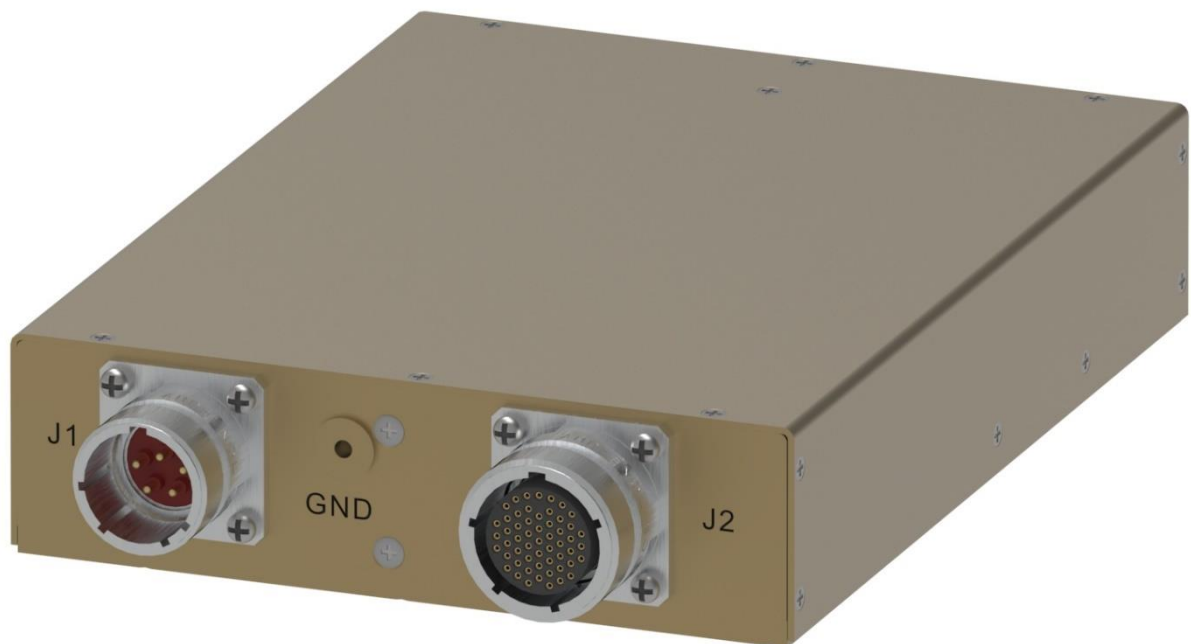

M8187 is a 2KW DC to DC, ruggedized, high-performance power supply designed for Airborne, Ground Mobile, Ground Fixed and other applications that are characterized by harsh and hostile environment. It is fed from a 270VDC power and provides a well-regulated filtered and protected 28VDC DC Output.

M8187– DC/DC POWER SUPPLY

Standard Configurations

Part number	Input	Output		Special features
	Voltage range	Voltage	Current	
M8187100	200-320V _{DC}	12 V _{DC}	70 A	
M8187101	200-320V _{DC}	15 V _{DC}	70 A	
M8187102	200-320V _{DC}	24 V _{DC}	70 A	
M8187103	200-320V _{DC}	28 V _{DC}	70 A	
M8187104	200-320V _{DC}	36 V _{DC}	55 A	
M8187105	200-320V _{DC}	48 V _{DC}	40 A	
M8187106	200-320V _{DC}	28 V _{DC}	70 A	Parallel operation via output voltage droop. Voltage regulation is $\pm 2\%$.

THE MAIN FEATURES OF THE M8187 ARE:

- DC/DC Single output converter.
- Input voltage range 270VDC per MIL-STD-704F for normal and abnormal transients.
- Output: 28VDC / 2kW.
- Baseplate cooled unit.
- Designed to meet MIL-STD-461G unshielded output power cables.
- Full galvanic isolation between Input, Chassis GND and Output.
- High efficiency 85% or better.
- Inhibit input.
- Units support paralleled (load-share) operation with equivalent units.
- Overvoltage Protection, Overcurrent Protection and Over Temperature Protection.
- Circular D38999 connectors.

M8187– DC/DC POWER SUPPLY

SPECIFICATIONS

DC Input	Voltage Range	200 to 320 V _{DC}
	Isolation	Input is galvanically isolated from output and chassis (> 20 MΩ at 500 VDC).
DC Output	Nominal Ratings	28 VDC / 2 kW
	Voltage Regulation	Up to ±1% (low to high line voltage, no load to full load, –55 °C to +85 °C at baseplate).
	Turn On Time	Within 1 second after a nominal 270 VDC power input is provided.
	Remote Sense	The SENSE is used to achieve accurate load regulations at load terminals (this is done by connecting the pins directly to the load's terminals). The use of remote sense has a limit of voltage dropout between converter's output and load terminals of 2-10% of voltage output (up to 2V). Please note that if Sense lines are not used the output may rise as much as 2V above nominal outputs. If sense lines are not to be used in the application, please inform factory for internal connection to output pins.
	Ripple & Noise	≤280 mVp-p, typical.
	Overcurrent Protection	Continuous protection (10 to 30% above maximum current) for unlimited time.
	Over Voltage Protection	<u>Passive Over-Voltage Protection</u> Passive transorb on output, 120% ± 10% of nominal voltage.
	Over Temperature Protection	Shutdown at baseplate temperature of +105 °C ± 5 °C. Automatic recovery at base plate temperature lower than +95 °C ± 5 °C.
	Paralleling	Multiple units can be paralleled and will share the load's current between them.
	Isolation	Output is galvanically isolated from chassis (> 20 MΩ at 100 VDC).
	Efficiency	85% or better over the entire operating temperature
Control & Indication	On/Off	The INHIBIT signal is used to turn the power supply ON and OFF. OPEN – will turn on the power supply. SHORT – between INHIBIT and INHIBIT RETURN will turn off the power supply. This signal is referenced to the SIGNAL RETURN pin.

M8187– DC/DC POWER SUPPLY

SPECIFICATIONS (CONT.):

EMC⁽¹⁾	MIL-STD-461G	CE102, CS101, CS114, CS115, CS116, RE102, RS101, RS103
Environment⁽¹⁾	Temperature	<u>Operating</u> : -55 °C to +85 °C (at baseplate)
	Altitude	MIL-STD-810G, Method 500.5 Procedures I – up to 70,000 ft. (non-operational) Procedure II – up to 70,000 ft. (operational)
	Humidity	MIL-STD-810G, Method 507.5 Up to 95% RH
	Vibration	MIL-STD-810G, Method 514.6 Category 7: Aircraft – Jet, IAW figure C-6, 13.7grams, 1 hour per axis. Category 24: Minimum integrity, IAW figure E-3, 7.7 grams, 1 hour per axis.
	Shock	MIL-STD-810G, Method 516.6 Operational shock: 30 g, 11 ms, half-sine Crash safety: 100 g, 6 ms, half-sine
	Fungus	Does not support fungus growth (MIL-STD-810G, Method 508.6)
	Salt Fog	MIL-STD-810G, , Method 509.5
Cooling Requirements	The M8187 is a baseplate cooled unit. The user must maintain the baseplate's temperature below +85 °C by thermally attaching it to a suitable heat sink.	
Size	7.5" wide, 9.6" length and 2.3" height For detailed dimensions and tolerances see Drawing: TBD	
Weight	TBD	
Connectors	DC Input: D38999/20TD05PN or eq. (For pinout see Table 1) DC Output: D38999/20TE35SN or eq. or equivalent (For pinout see Table 2)	

Notes:

(1) Designed to meet

M8187– DC/DC POWER SUPPLY

PIN ASSIGNMENT: TABLE 1– INPUT CONNECTOR

Type: D38999/20TD05PN or eq.

Pin No.	Function
A	V _{IN} (+)
B	V _{IN} (+)
C	V _{IN} RTN (-)
D	V _{IN} RTN (-)
E	CHASSIS

PIN ASSIGNMENT: TABLE 2: OUTPUT CONNECTOR

Type: D38999/20TE35SN or eq.

Pin No.	Function
30, 32 – 38, 40 – 55	V _{OUT} (+)
1 – 16, 18 – 23, 26, 29	V _{OUT} RTN (-)
25	SENSE (+)
17	SENSE RTN (-)
31	INHIBIT
24	INHIBIT RTN
39	CHASSIS
27, 28	N/C

FIGURE 1: CONNECTION DIAGRAM:

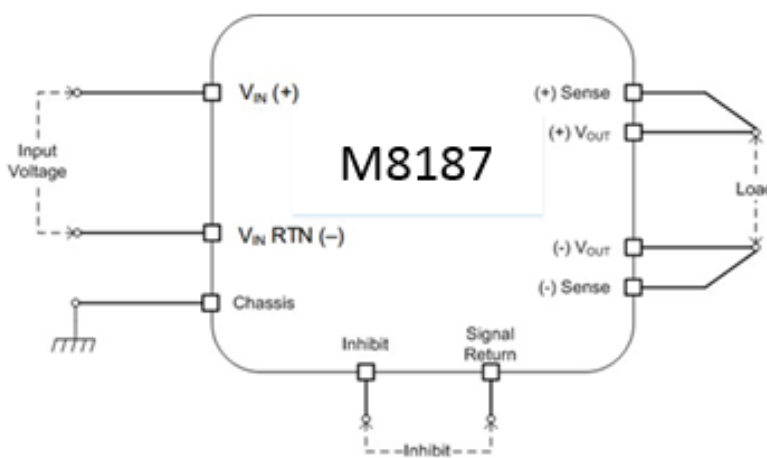

M8187- DC/DC POWER SUPPLY

OUTLINE DRAWING

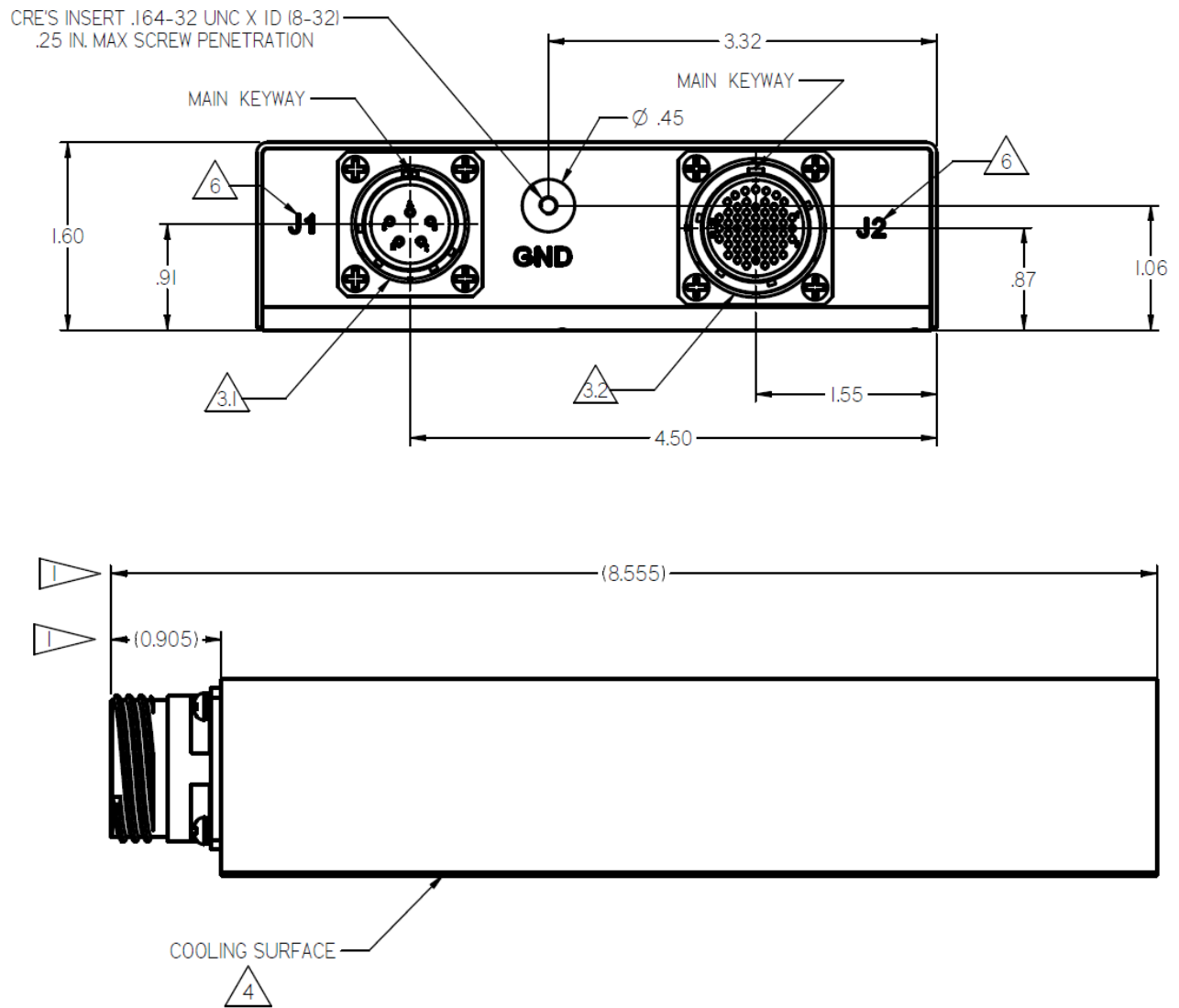

M8187- DC/DC POWER SUPPLY

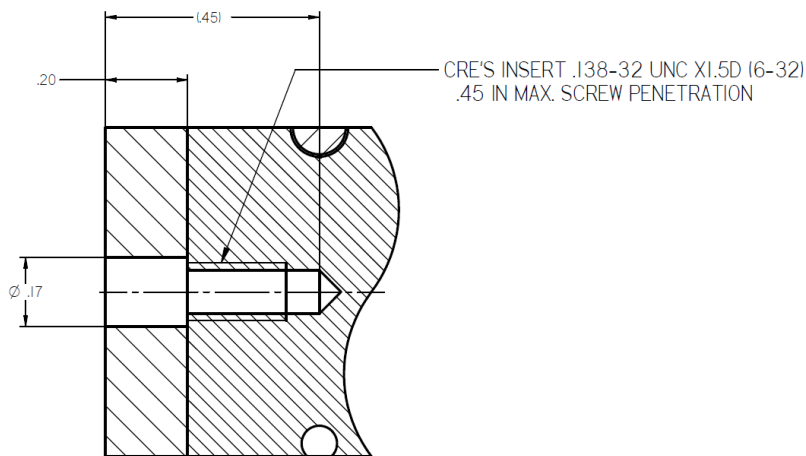
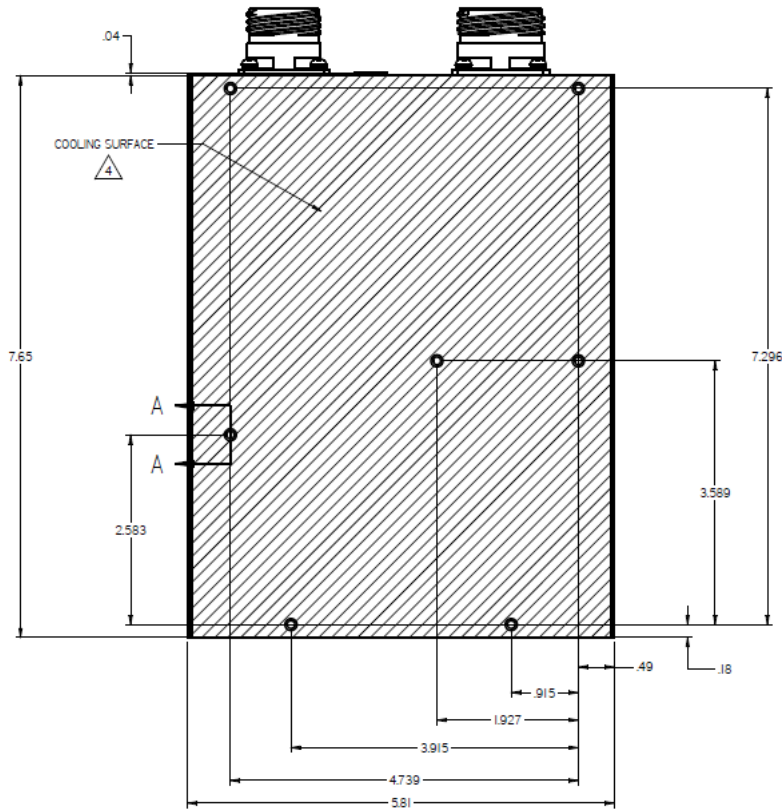

SECTION A-A
5:1
7 PLACED

M8187- DC/DC POWER SUPPLY

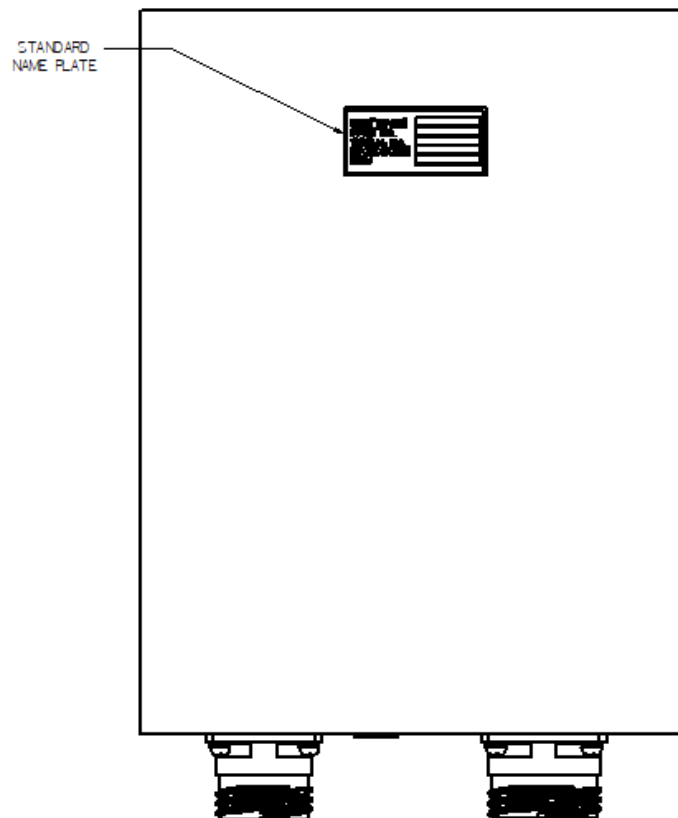

NOTES :

1. MATERIAL: AL 6061-T651 & AL 5052-H32 OR EQ. EQ.
2. FINISH: CHROMATE CONVERSION COATING PER MIL -DTL-5541F, TYPE I CLASS IA OR EQ.
3. CONNECTORS:
 - 3.1. J1- INPUT CONNECTOR: INPUT CONNECTOR D38999/20TD5PN OR EQ.
 - 3.2. J2- OUTPUT CONNECTOR: OUTPUT CONNECTOR D38999/20TE35SN OR EQ.
4. COOLING: HEAT DISSIPATION AREA- 26825 [mm²].
5. WORKMANSHIP SHALL BE MIL-STD-454, REQT. 9
6. ENGRAVING
 - 6.1. CHARACTER HEIGHT : 4.0 MM.
 - 6.2. CHARACTER DEPTH : 0.5 MM.
 - 6.4. CHARACTER ARE CENTRALLY LOCATED,
 - 6.5. FILL ENGRAVING WITH BLACK LUSTERLESS EPOXY PAINT COLOR PER FED-STD 595 NO : 37038.

Note: Specifications are subject to change without prior notice by the manufacturer