

## M8637 SERIES

*DC/DC POWER SUPPLY*



### PRODUCT HIGHLIGHTS

- MINIATURE
- HIGH DENSITY
- TRIPLE OUTPUT
- DC/DC CONVERTERS
- UP TO 125W

### Applications

Military, Ruggedized, Telecom, Industrial

### Special Features

- Miniature size
- High efficiency
- Wide input range
- Input / Output isolation
- Fixed switching frequency (250 kHz)
- External synchronization capability
- TTL logic enable
- EMI filters included
- Indefinite short circuit protection with auto-recovery
- Over temperature protection

### Environmental Conditions

Designed to meet MIL-STD-810F

#### Temperature:

Operating  $-55\text{ }^{\circ}\text{C}$  to  $+85\text{ }^{\circ}\text{C}$  (baseplate)

Storage  $-55\text{ }^{\circ}\text{C}$  to  $+125\text{ }^{\circ}\text{C}$

#### Altitude:

Method 500.4, Procedures I & II up to 70,000 ft. Operational

#### Humidity:

Method 507.4 - Up to 95% RH (including condensation)

#### Salt Fog:

Method 509.4

#### Vibration and Shock:

Shock: Saw-tooth, 20 g peak, 11 ms.

Vibration: Figure 514.5C-17 general minimum integrity exposure (1 hour per axis)

### Reliability

150,000 hours calculated per MIL-STD-217F Notice 2, at  $+85\text{ }^{\circ}\text{C}$  baseplate, Ground Fixed.

### Electrical Specifications

#### DC INPUT

Normal voltage range: 18 to 70 V<sub>DC</sub>

Option: 12 to 70 V<sub>DC</sub> – *consult factory*

#### Abnormal transient protection:

No damage (may shut down) when exposed to abnormal transients IAW MIL-STD-1275A (100 V for 50 ms) and MIL-STD-704A (80 V for 0.1 s)

Efficiency: up to 80%

EMC: Designed to meet MIL-STD-461F\*

CE101, CE102, CS101, CS114, CS115, CS116, RE101, RE102, RS101, RS103

#### Isolation:

Input to Output:

200 V<sub>DC</sub> Input to Case:

200 V<sub>DC</sub>

#### DC OUTPUT (floating)

#### Line/Load regulation:

Up to  $\pm 1\%$  (no load to full load,  $-55\text{ }^{\circ}\text{C}$  to  $+85\text{ }^{\circ}\text{C}$ )

Ripple and Noise: 50 mV<sub>p-p</sub>, typical (max. 1%)

#### Current limiting (Hiccup):

Continuous protection for unlimited time

#### Over Voltage Protection:

Passive transorbs on outputs.

#### Over Temperature

#### Protection:

Shutdown if baseplate temperature exceeds  $+105\text{ }^{\circ}\text{C} \pm 5\text{ }^{\circ}\text{C}$ ; Automatic recovery upon cooldown to below  $+95\text{ }^{\circ}\text{C} \pm 5\text{ }^{\circ}\text{C}$ .

#### Isolation:

Output to Case: 100 V<sub>DC</sub>

---

\* EMC compliance achieved when tested with 5  $\mu\text{H}$  LISNs, shielded harness and static resistive load.

## M8637 SERIES DC/DC POWER SUPPLY

### Operational Block Diagram

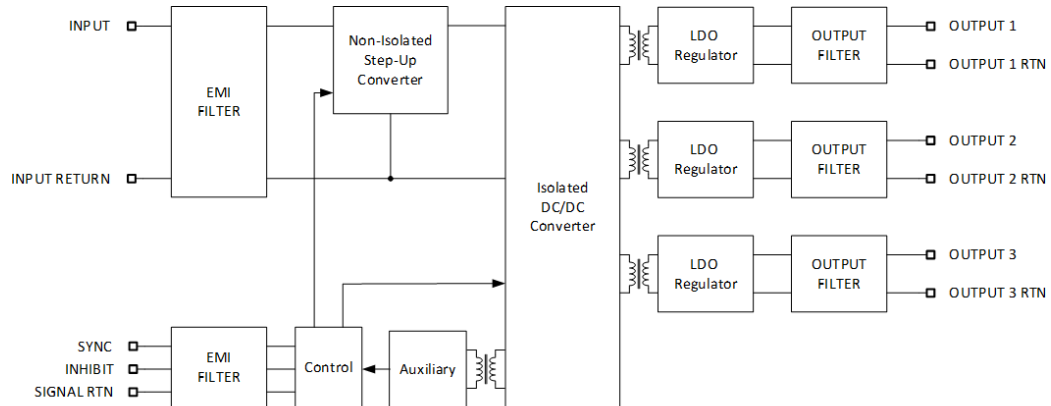

### Outputs Range

Output #	Voltage Range	Current Range	Power Range
1	3.3 to 28 V <sub>DC</sub>	0 to 10 A	0 to 50 W
2	3.3 to 28 V <sub>DC</sub>	0 to 6 A	0 to 50 W
3	7 to 28 V <sub>DC</sub>	0 to 6 A	0 to 50 W
<b>Total</b>			0 to 125 W

### Typical Connection Diagram

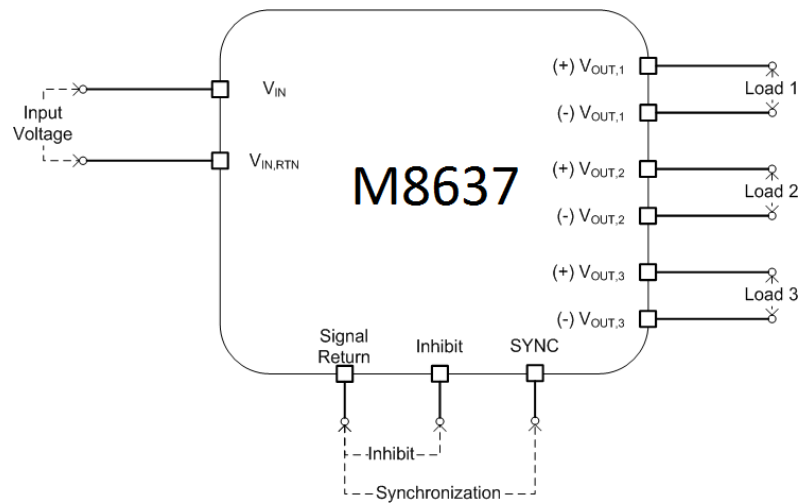

## M8637 SERIES DC/DC POWER SUPPLY

### Pin Assignment\*

Connector type: 55302/61-A30

Mates with: M55302/62-A30M (solder cup termination) or M55302/66-30M (#22 AWG crimp termination) or eq.

Pin No.	Function	
1	OUT 1 (+)	●
2	OUT 1 (+)	●
3	OUT 1 (+)	●
4	OUT 1 RTN (-)	○
5	OUT 1 RTN (-)	○
6	OUT 2 (+)	●
7	OUT 2 RTN (-)	○
8	OUT 3 (+)	●
9	OUT 3 RTN (-)	○
10	N.C.	

Pin No.	Function	
11	SIGNAL RTN	●
12	VIN RTN (-)	●
13	VIN RTN (-)	●
14	VIN (+)	●
15	VIN (+)	●
16	OUT 1 (+)	●
17	OUT 1 (+)	●
18	OUT 1 RTN (-)	○
19	OUT 1 RTN (-)	○
20	OUT 1 RTN (-)	○

Pin No.	Function	
21	OUT 2 (+)	●
22	OUT 2 RTN (-)	○
23	OUT 3 (+)	●
24	OUT 3 RTN (-)	○
25	INHIBIT	●
26	VIN RTN (-)	●
27	VIN RTN (-)	●
28	VIN (+)	●
29	VIN (+)	●
30	SYNC	●

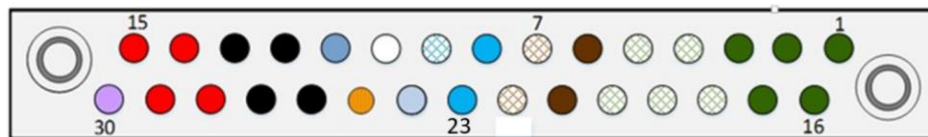

\* For optimal performance, connect all pins with identical designation together.

### ***Functions and Signals***

#### **INHIBIT**

The ***INHIBIT*** signal is used to turn the power supply ON and OFF.

TTL "1" or OPEN – Power supply is ON (For normal operation, leave this pin unconnected.)

TTL "0" or SHORT to ***SIGNAL RTN*** – Power supply is OFF.

#### **SYNC**

The ***SYNC*** signal is used to allow the power supply's switching frequency to sync with the system clock.

The external clock's frequency can be 250 kHz  $\pm$  10 kHz.

When this pin is left open (unconnected) the power supply will synchronize to its internal clock, set at 250 kHz  $\pm$  10 kHz.

#### **SIGNAL RTN**

The ***SIGNAL RTN*** is used as a return path for the ***SYNC*** and ***INHIBIT*** signals.

This pin is referenced to ***VIN RTN***.

### Outline Drawing

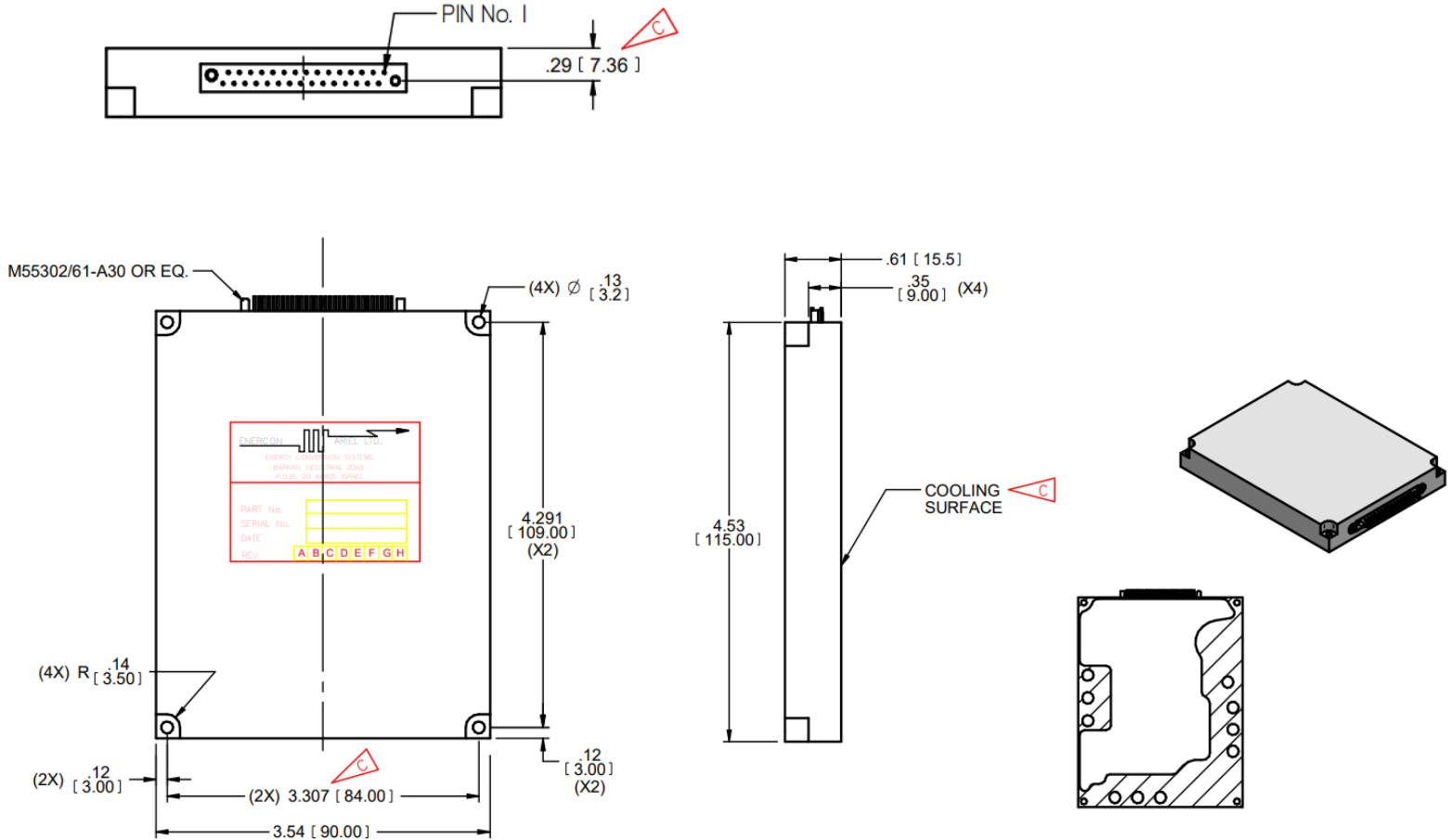

UNLESS OTHERWISE SPECIFIED  
DIMENSIONS ARE IN INCHES (MM).  
TOLERANCES ARE:

DECIMALS	ANGLES
.XX± 0.02	±
.XXX± 0.010	

DO NOT SCALE DRAWING

#### NOTES :

1. MATERIAL: ALUMINUM ALLOY (6061-T65) & 5052-H32)
2. FINISH: CHEMICAL CONVERSION COATING MIL-DTL-5541 LAST REV, TYPE I, CLASS IA
3. WORKMANSHIP SHALL BE MIL-STD-454, REQ. 9
4. HEAT DISSIPATION AREA - 6.045 IN<sup>2</sup>

### Standard Models List (for other voltages – consult factory)

Part number	Input	Output 1		Output 2		Output 3	
	Voltage range	Voltage	Current	Voltage	Current	Voltage	Current
M8637100	18 to 48 V <sub>DC</sub>	5 V <sub>DC</sub>	10 A	3.3 V <sub>DC</sub>	6 A	12 V <sub>DC</sub>	4 A
M8637101	18 to 48 V <sub>DC</sub>	5 V <sub>DC</sub>	10 A	3.3 V <sub>DC</sub>	6 A	28 V <sub>DC</sub>	1.7 A
M8637102	18 to 48 V <sub>DC</sub>	5 V <sub>DC</sub>	6 A	15 V <sub>DC</sub>	3 A	15 V <sub>DC</sub>	3 A
M8637103	18 to 48 V <sub>DC</sub>	5 V <sub>DC</sub>	6 A	12 V <sub>DC</sub>	4 A	12 V <sub>DC</sub>	4 A
M8637104	18 to 48 V <sub>DC</sub>	5 V <sub>DC</sub>	1.25 A	15 V <sub>DC</sub>	3.2 A	15 V <sub>DC</sub>	3.2 A

- Additional standard configurations available. **Contact factory for more details.**
- All of our products can be configured to comply with EU REACH regulations. **Contact factory for more details.**

*Note: Specifications are subject to change without prior notice by the manufacturer.*