

M9516 SERIES

8 Channels, 200A, Power Distribution Unit

M9516 is a 8-channel power distribution unit, designed for land vehicle applications. It distributes 28VDC through overload and short-circuit protected switches. The M9516 supports CAN and RS-485 communication to control, configure and get the status of the device.



M9516 SERIES— Power Distribution Unit

STANDARD CONFIGURATIONS

Part Number	Current Switch	Special Features
M9516101	See Output Rating Table for M9516	

M9516 Standard Configuration Output Ratings:

Output	Full-Load Current
OUT1	25A
OUT2	25A
OUT3	25A
OUT4	25A
OUT5	25A
OUT6	25A
OUT7	25A
OUT8	25A

* Additional standard configurations available. **Contact factory for more details.**

* All our products can be configured to comply with **EU REACH** regulations.

The main features of the M9516 SERIES are:

- User defined maximum current per channel – Current Limit
- Large capacitance charge capability
- 1 input 8 outputs Power distribution unit.
- Configurable current breaker per Switch – Overload Protection Switch
- I²t curve for overload switching delay duration
- Configurable turn-on sequence by card wakeup and by discrete input
- Meets MIL-STD-1275E
 - Steady state Voltage levels 6V - 33V
 - Surge 100V 50ms & Spike 250V 70μs
 - Reverse voltage protection for both card and consumers
- Meets MIL-STD- 461E/F
- Interface and control:
 - RS-485 interface
 - CAN interface
 - 5 Discrete inputs
 - 1 Discrete output (Trip error output)
 - Manual shutdown input

M9516 SERIES– Power Distribution Unit

Specifications:

Input	Voltage	6 to 33VDC steady state. Fully compliant with MIL-STD-1275E.
	Surges and Spikes	IAW MIL-STD-1275A-E. Input clamp at 65V for device and loads.
	Reverse Polarity Protection	Device and loads protected on occasion of reverse voltage application.
	Under Voltage Lockout	Device and outputs turn off when input voltage drops below 5.5 V. Device turns back on when input voltage rises above 6 V.
Outputs	Rating	Each output supports 30A steady state current
	Drop Voltage	175mV maximum at rated current.
	Overload Protection	Configurable from 2A up to outputs rated current with 5% accuracy. Trip by I ² t curve see overload curve.
	Short Circuit Protection	Configurable from 10A to 125A with 20% accuracy. Protection is active, preventing from the short to spread through system. See short circuit curve.
	Capacitive Load Charge	9mF @ Vin = 28V, I _{LIM} = 13A 3.5mF @ Vin = 33V, I _{LIM} = 125A 7mF @ Vin = 28V, I _{LIM} = 20A Option to charge much greater capacitance, consult factory.
	Paralleling Outputs	Outputs can be paralleled to achieve higher rated outputs.
Control & Indication	CAN	Bitrate of 250Kbps to 1Mbps. Default bitrate 250Kbps. Differential input resistance of 100KΩ.
	RS-485	Baudrate of 1200bps to 115200bps. Default baudrate of 19200. Differential input resistance of 100KΩ. Differential driver output 2V to 3.37V Input receiver threshold between 50mV to 200mV.
	Discrete Inputs	Three inputs for functionality control (RAT, DCI, BATTLE see overview) Two default communication mode pins Three address pins
	Discrete Output	Has one fault indication (see overview)
	Measurements	Input and outputs voltages Outputs current Device Temperature

M9516 SERIES– Power Distribution Unit

Specifications (Cont.):

Environment	Ambient Temperature	Non-operating ambient : -55°C to +125°C Operating : -55°C to + 105°C. (at unit's edges)
	Humidity	Up to 95% RH, Per MIL-STD-810F, Method 507.4
	Salt-fog	Per MIL-STD-810F, Method 509.4
	Altitude	Method 500.4, Procedure I & II, 40,000 ft. and 70,000 ft. Operational
	Mechanical Shock	Saw-tooth, 40 g peak, 11 ms.
	Vibration	Figure 514.5C-17. General minimum integrity exposure. (1 hour per axis)
EMI	MIL-STD-461G	CE101, CE102, CS101 CS114 (10 kHz to 400 MHz, Curve #5), CS115, CS116, RE101, RE102 (Fixed wing external), RS101 and RS103 (2 MHz to 18 GHz 50 V/m). All tests are at full load and in accordance with the provisions of MIL-STD-461G – with shielded signals.
MTBF	250,000 hours, calculated per MIL-STD-217F at +50 °C at wedge lock edge, Ground	
Weight	TBD	
Connectors	Input: CONEC 3024W7PCU60N20X or eq Output: CONEC 3008W8SXX58N20X or eq. Mating connectors: Input: P/N: CONEC 3024W7SXX99A10X or eq. Crimp pins AWG 20-24 P/N: CONEC 162C18709X or eq. Crimp pins AWG 8-10 P/N: CONEC 132C11049X or eq. Output: P/N: CONEC 3008W8PXX99A10X or eq. Crimp pins AWG 8-10, P/N: CONEC 131C11149X or eq.	

M9516 SERIES– Power Distribution Unit

Pin Assignment:

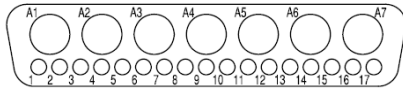

24W7

J1 - Input	
CBM24W7M570000/AA	
Pin	Function
A1	VIN
A2	VIN
A3	VIN
A4	VIN
A5	VIN
A6	VIN
A7	VIN_RTN
1	CAN_L
2	CAN_H
3	BATTLE_OVERRIDE_N
4	DCI_N
5	BR1
6	BR2
7	ADDR_RTN
8	ADDR_1
9	FAULT_OUT
10	ADDR_2
11	RAT
12	ADDR_3
13	SHUTDOWN_N
14	28VDC_RTN
15	COM_GND
16	RS_485_P
17	RS_485_N

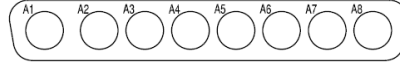

8W8

J2 - Output	
CBM8W8S570000/AA	
Pin	Function
A1	CH7_OUT
A2	CH6_OUT
A3	CH5_OUT
A4	CH4_OUT
A5	CH3_OUT
A6	CH2_OUT
A7	CH1_OUT
A8	CH0_OUT

M9516 SERIES– Power Distribution Unit

Typical Characteristics

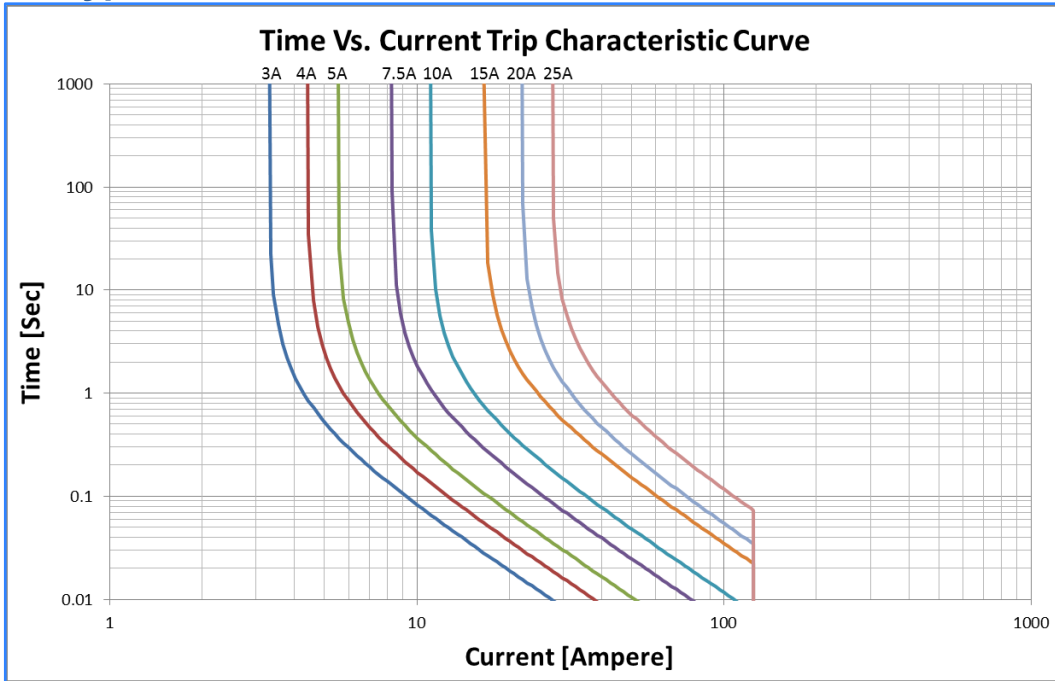

Figure 1 - Time vs. Current Overload Trip

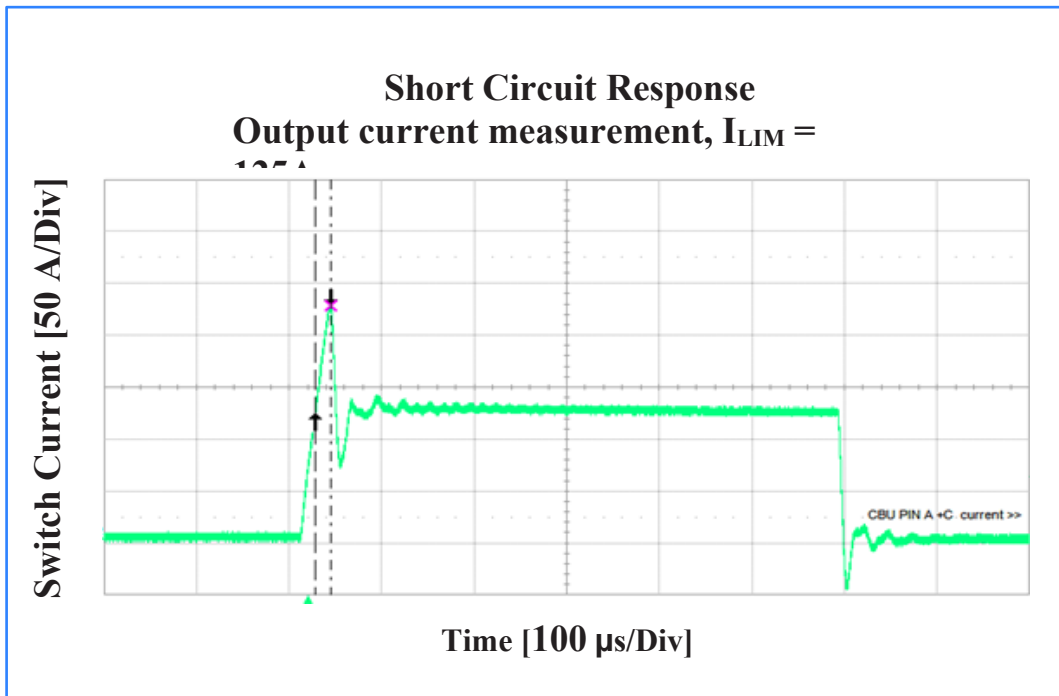

Figure 2 - Short Circuit Response

Overview

Interface Description

POR

Power On Reset (POR) is a sequence of operations that happens automatically when device starts up. The PDU can start pre-defined switches automatically on POR and wait a predefined amount of time between each switch. The delay and sequencing options let the whole system to start smoothly with as low as possible stress.

To configure POR the user should send a macro command with element = 230 and State = 1. Later the user should send commands that support macros like switch on/off and delay. When complete the user should send the macro command again but with State = 0.

Discrete Inputs

M9516 SERIES has 5 discrete open/short inputs which can help control the device. All inputs are with respect to 28VDC_RTN (pin 14).

BATTLE_SHORT_N - active low input signal. If active, then all outputs are switched to battle mode. Switch will not trip due to overload, but it will trip in case of short circuit. If short-circuit occur, then the switch will trip but will shortly resume in an auto retry mode.

DCI_N – Transition from high to low will start a macro. Macro can enable or disable selected outputs. Each output can turn on or off in delay from previous output.

RAT –Transition from high to low will reset the trip status of all outputs.

BR1 – pulling this pin to 28VDC_RTN through power up will make the CAN-BUS interface to be in default configuration. See table below.

BR2 – pulling this pin to 28VDC_RTN through power up will make the RS-485 interface to be in default configuration. See table below.

BR1	BR2	CAN bitrate	RS-485 baudrate
High	High	User Configuration	User Configuration
Low	High	250kbps	User Configuration
High	Low	User Configuration	19200
Low	Low	250kbps	19200

Each input has the following interface:

M9516 SERIES– Power Distribution Unit

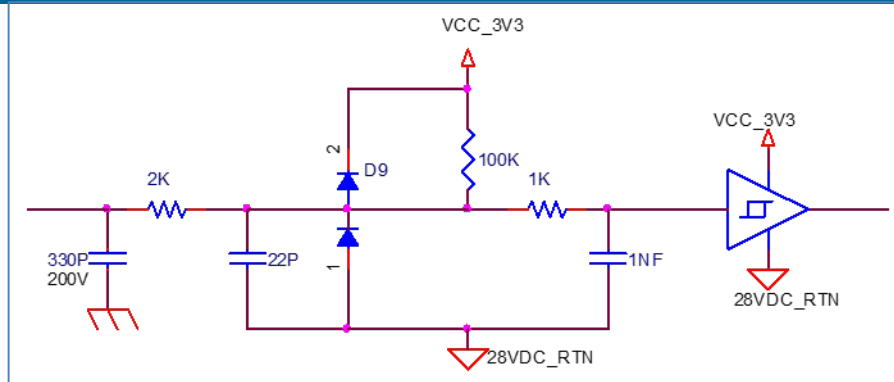

Figure 3 – Discrete input interface

Address Input

ADDR[3:1] – Address bits used for communication address (see Communication Interface section) and for configuration loading. On startup the address is set for communication and one of the 8 possible configurations is loaded according to Page Mapping command.

ADDRx is Open short line. Open is logic high, short is logic low. See tables below.

ADDR3	ADDR2	ADDR1	Address
High	High	High	7
High	High	Low	6
High	Low	High	5
High	Low	Low	4
Low	High	High	3
Low	High	Low	2
Low	Low	High	1
Low	Low	Low	0

All address inputs are with respect to ADDR_RTN (pin 7). Each address input has the following interface:

M9516 SERIES– Power Distribution Unit

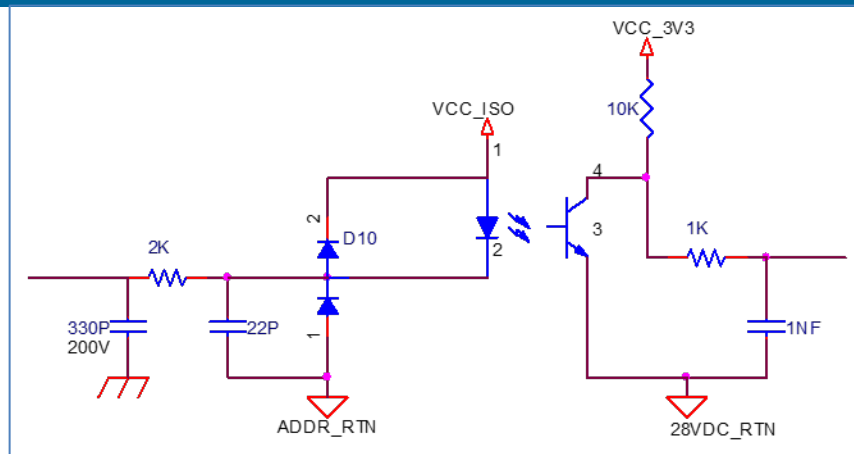

Figure 4 – Address input interface

Discrete Outputs

FAULT_OUT is active low signal, if any of the outputs trip, then the FAULT_OUT signal is shorted to 28VDC_RTN (pin 14).

FAULT_OUT has the following interface:

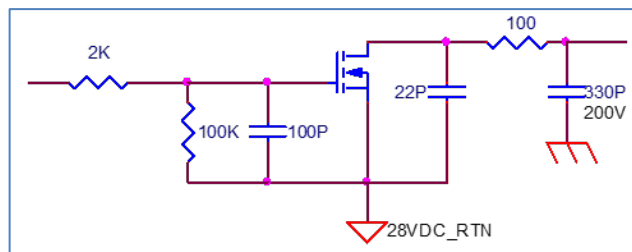

Figure 5 – Fault output interface

M9516 SERIES– Power Distribution Unit

Shutdown Pin

SHUTDOWN_N is active low input signal. If shorted to 28VDC_RTN (pin 14) then the internal VCC of the device will drop causing a complete shutdown and minimal quiescent current.

SHUTDOWN_N interface:

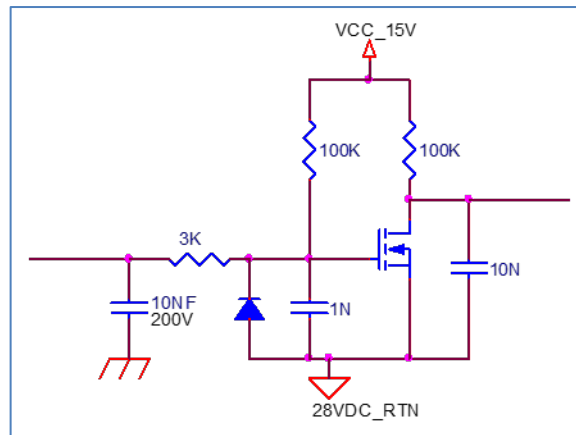

Figure 6 – Shutdown input interface

M9516 SERIES– Power Distribution Unit

Communication Interface

M9516 Series has two communication interfaces: CAN BUS and RS-485. Both are isolated from 28VDC_RTN and with respect to IS_COM_GND (pin 15). Communication can work simultaneously from both interfaces when respond messages will be sent to the interface where the command has come from.

RS-485 Messages

Message Structure

The communication is ASCII coded. Every RS-485 packet starts with ‘:’ char and ends with ‘\r\n’ chars. Message format is:

Parameter	Description	Values	Type
Start Byte	Each packet start with this byte. If previous message didn't complete receiving it will be discarded.	‘:’ (0x3A)	char
Address	Address to which the message is intended.	{0b110,ADDR[3:1],0b00}	Uint8
Type	The purpose of the message.	0x65 – RS-485 Configuration 0x67 – All other messages	Uint8
Payload	The payload data of the message	If Type is 0x65 see below If type is 0x67 see Message Payload section	Uint8[8]
Checksum	Message error detection checksum byte	See calculation	Uint8
End Bytes	Each packet ends with these bytes.	‘\r\n’ (0x0D0A)	Char[2]

Payload for 0x65 messages

0x65 message is used to configure the RS-485 protocol parameters. Payload structure is:

Parameter	Description	Values	Type
Baudrate	Baud rate to be used in none default mode. Formula: 2995200/(Baudrate in bps)	26 - 2496 Default is 156	Uint16
Parity	Parity selected	0 – None 1 – Even 2 – Odd	Uint8
Timeout	Byte timeout for which a message will be discarded. Formula: (time in seconds) * 0.1	1 – 50 Default is 10	Uint8
Null	Not used bytes	Don't care	Uint8[4]

M9516 SERIES— Power Distribution Unit

Checksum calculation

Checksum is calculated without the start and end bytes, the sum of the bytes modulo 256 should be zero.

CAN BUS Messages

Message Structure

The PDU is using SAE J1939 over CAN. The CAN ID structure for all messages sent to PDU is:

0xC77E	ADDR[3:1]	0x0	Source Computer Address
Length 16 bits	Length 3 bits	Length 2 bits	Length 8 bits

Followed by Control set for data frame and 8 bytes of data.

CAN ID for return messages from PDU will be:

0x18EF	Source Computer Address	0x6	ADDR[3:1]	0x0
Length 13 bits	Length 8 bits	Length 3 bits	Length 3 bits	Length 2 bits

Followed by Control set for data frame and 8 bytes of data.

Alert messages will be with the following CAN ID format:

0x18FFF1	0x6	ADDR[3:1]	0x0
Length 21 bits	Length 3 bits	Length 3 bits	Length 2 bits

Followed by Control set for data frame and 8 bytes of data.

The Data bytes for CAN message are the same as the payload bytes for 0x67 RS-485 messages and appear in the Message Payload section.

M9516 SERIES— Power Distribution Unit

Message Payload

Payload general structure

The data is in format of little-endian. Payload structure to both CAN and RS-485 Messages:

Parameter	Description	Values	Type
OpCode	A code to specify the command	Odd number x for command Even number x+1 for response	Uint8
Status	A field applicable to response only notifying the execution status of the command.	See Status Values table	Bit[6]
R/W	A flag to set the command as write or read or macro command. Not all opcodes have all the options	0 – Read 1 – Write 2 – Macro	Bit[2]
Data	A data related to the opcode. If data is less than 6 bytes, then it will be padded with zeros.	See next paragraphs	

M9516 SERIES– Power Distribution Unit

Status values and meaning:

Table 1 - Status values

Status Value	Description
0x00	Successful execution
0x01	General R/W error
0x02	Read not supported for opcode
0x03	Write not supported for opcode
0x05	Error writing to flash
0x07	Wrong element selected
0x08	Channel number doesn't exist
0x09	Group number doesn't exist
0x0A	Sensor doesn't exist
0x0B	Board doesn't exist
0x0C	Wrong address
0x0D	Wrong page
0x14	Wrong State
0x17	Wrong flash index
0x18	Wrong flash key
0x20	Group is empty
0x30	Current limit or overload threshold is out of bounds
0x3E	Opcode doesn't exist
0x3F	General Error

M9516 SERIES– Power Distribution Unit

Controls

Channel Control 1

The command turns on or off a channel or a group. If selected write command than the channel or group will be affected immediately. If selected as part of macro sequence than the channel or group will be affected when macro is triggered.

Parameter	Description	Values	Type
OpCode	A code to specify the command	0x01 for command 0x02 for response	Uint8
Status	A field applicable to response only notifying the execution status of the command.	See Status Values table	Bit[6]
R/W	A flag to set the command as write or read or macro command.	1 – Write 2 – Macro	Bit[2]
Element	The Channel or group to control	Channel 0-99 : 0 – 99 Group 0-49 : 100 - 149	Uint8
State	Turn on or off selection	0 – Turn off 1 – turn on	Uint8

Channel Control 2

The command enables or disables battle mode for channel or a group. When enabled, the channel or group will disconnect due to over load. In case of short circuit, the switch will disconnect only if overheated and after it cools it will retry. If selected write command than the channel or group will be affected immediately. If selected as part of macro sequence than the channel or group will be affected when macro is triggered.

Parameter	Description	Values	Type
OpCode	A code to specify the command	0x03 for command 0x04 for response	Uint8
Status	A field applicable to response only notifying the execution status of the command.	See Status Values table	Bit[6]
R/W	A flag to set the command as write or read or macro command.	1 – Write 2 – Macro	Bit[2]
Element	The Channel or group to control	Channel 0-99 : 0 – 99 Group 0-49 : 100 - 149	Uint8
Battle	Battle mode enable disable	0x00 – Disable 0x0D – Enable Else – No action	Uint8

M9516 SERIES– Power Distribution Unit

Reset

The command resets the device immediately.

Parameter	Description	Values	Type
OpCode	A code to specify the command	0x07 for command 0x08 for response	Uin8
Status	A field applicable to response only notifying the execution status of the command.	See Status Values table	Bit[6]
R/W	A flag to set the command as write or read or macro command.	1 – Write	Bit[2]

Status

Channel Status 1

Parameter	Description	Values	Type
OpCode	A code to specify the command	0x21 for command 0x22 for response	Uin8
Status	A field applicable to response only notifying the execution status of the command.	See Status Values table	Bit[6]
R/W	A flag to set the command as write or read or macro command.	0 – Read	Bit[2]
Element	The Channel or group to control	Channel 0-99 : 0 – 99 Group 0-49 : 100 - 149	Uin8
Current	Current of selected channel or group	Current = Value*0.01 – 80,000	Uin24
Voltage	Voltage of selected channel or group	Voltage = Value*0.05 – 1,606	Uin16

M9516 SERIES– Power Distribution Unit

Channel Status 2

Parameter	Description	Values	Type
OpCode	A code to specify the command	0x25 for command 0x26 for response	Uint8
Status	A field applicable to response only notifying the execution status of the command.	See Status Values table	Bit[6]
R/W	A flag to set the command as write or read or macro command.	0 – Read	Bit[2]
Element	The Channel or group to control	Channel 0-99 : 0 – 99 Group 0-49 : 100 - 149	Uint8
SwState	Switch physical state	0 – Off 1 - On	Bit[2]
CmdState	Switch commanded state	0 – Off 1 - On	Bit[2]
OutputV	Output voltage is greater than 60% of input	0 – Voltage is low 1 – Voltage is high	Bit[2]
OutputI	Output current is greater than 30% of overload setting current	0 – Current is high 1 – Current is high	Bit[2]
Trip	Trip status of output	0 – No trip has occurred 1 – Trip has occurred	Bit[2]
BIT	BIT Status of selected output. Bit is asserted when output voltage doesn't appear when switch is supposed to be on (on command and no trip) or when voltage or current appear when switch is supposed to be off (off command or trip)	0 – Normal 1 - Error	Bit[2]
Battle	Battle status of output	0 – Normal 1 – Battle	Bit[2]
Group	Group of selected output	0 – 50 when grouped 251 – when not grouped	Uint8
N\A	For future use		Uint8
N\A	For future use		Bit[6]
Sharing	Status of current distribution between to switches of same group. Asserted when more than 10% difference between switches	0 – OK 1 – Current isn't shared	Bit[2]

M9516 SERIES– Power Distribution Unit

Input Status

Parameter	Description	Values	Type
OpCode	A code to specify the command	0x27 for command 0x28 for response	Uint8
Status	A field applicable to response only notifying the execution status of the command.	See Status Values table	Bit[6]
R/W	A flag to set the command as write or read or macro command.	0 – Read	Bit[2]
Element	Selection of input	190	Uint8
Current	Current of selected channel or group	Current = Value*0.01 – 80,000	Uint24
Voltage	Voltage of selected channel or group	Voltage = Value*0.05 – 1,606	Uint16

Temperature

Parameter	Description	Values	Type
OpCode	A code to specify the command	0x33 for command 0x34 for response	Uint8
Status	A field applicable to response only notifying the execution status of the command.	See Status Values table	Bit[6]
R/W	A flag to set the command as write or read or macro command.	0 – Read	Bit[2]
Element	Selection of input	152	Uint8
Temperature	Board temperature in degrees centigrade	Temp. = Value*0.03125 – 273	Uint16

M9516 SERIES– Power Distribution Unit

Grouped Channels

Parameter	Description	Values	Type
OpCode	A code to specify the command	0x35 for command 0x36 for response	Uint8
Status	A field applicable to response only notifying the execution status of the command.	See Status Values table	Bit[6]
R/W	A flag to set the command as write or read or macro command.	0 – Read	Bit[2]
Element	Selection of input	Group 0-49 : 100 - 149	Uint8
N\A	For future use		Uint8
Channel_0	Channel 0 membership to the specified group	0 – Channel 0 is not part of the group 1 - Channel 0 is part of the group	Bit[2]
Channel_1	Channel 1 membership to the specified group	0 – Channel 1 is not part of the group 1 - Channel 1 is part of the group	Bit[2]
Channel_7	Channel 7 membership to the specified group	0 – Channel 7 is not part of the group 1 - Channel 7 is part of the group	Bit[2]

M9516 SERIES– Power Distribution Unit

Configuration

Channel Setting

Parameter	Description	Values	Type
OpCode	A code to specify the command	0x61 for command 0x62 for response	UInt8
Status	A field applicable to response only notifying the execution status of the command.	See Status Values table	Bit[6]
R/W	A flag to set the command as write or read or macro command.	0 – Read 1 – Write	Bit[2]
Element	Selection of input	Channel 0-99 : 0 – 99 Group 0-49 : 100 - 149	UInt8
OverLoad	Overload threshold setting, where I2T curve is active	Current = Value*0.01 – 80,000	UInt24
CLimit	Current limit threshold setting, where active current limit is applied to protect from short circuit	Current = Value*0.5	UInt16

Calibration

Parameter	Description	Values	Type
OpCode	A code to specify the command	0x67 for command 0x68 for response	UInt8
Status	A field applicable to response only notifying the execution status of the command.	See Status Values table	Bit[6]
R/W	A flag to set the command as write or read or macro command.	1 – Write	Bit[2]
Element	Selection of channel	Channel 0-99 : 0 – 99	UInt8
CalType	Calibration type	0 – Offset Calibration 1 – Current Slope 2 – Voltage Slope 3 – Factory Setting	UInt8
Data	Data relative to CalType field	See table below	UInt8[3]

M9516 SERIES– Power Distribution Unit

R/W	CalType	Data
Write	Offset calibration	If channel is off than an offset calibration is performed for current and voltage management. Data will be ignored If channel is off than the message will return Error 0x3F(General)
Write	Current Slope	Data[3:0] – the current measured externally formatted as value = Current*100 + 8,000,000
Write	Voltage Slope	Data[3:0] – the voltage measured externally formatted as value = Voltage*20 + 32,120
Write	Factory Setting	Set to Factory setting. Data is ignored.

Save Configuration

Parameter	Description	Values	Type
OpCode	A code to specify the command	0x71 for command 0x72 for response	UInt8
Status	A field applicable to response only notifying the execution status of the command.	See Status Values table	Bit[6]
R/W	A flag to set the command as write or read or macro command.	1 – Write	Bit[2]
FlashPage	Flash page where current configuration will be saved	0 - 7	UInt8
MagicNum	Magic number to enable configuration save	0xACAB	UInt16

M9516 SERIES– Power Distribution Unit

Page Mapping

Parameter	Description	Values	Type
OpCode	A code to specify the command	0x73 for command 0x74 for response	Uin8
Status	A field applicable to response only notifying the execution status of the command.	See Status Values table	Bit[6]
R/W	A flag to set the command as write or read or macro command.	0 – Read 1 – Write	Bit[2]
Address	Address for the flash page to link to.	0 - 7	Uin8
Page	Flash page to link to Address	0 – 7	Uin8
Page_2	Flash page to link to Address+1	0 – 7 – in order to link 255 – in order to ignore	Uin8
Page_3	Flash page to link to Address+2	0 – 7 – in order to link 255 – in order to ignore	Uin8
Page_4	Flash page to link to Address+3	0 – 7 – in order to link 255 – in order to ignore	Uin8
Page_5	Flash page to link to Address+4	0 – 7 – in order to link 255 – in order to ignore	Uin8

M9516 SERIES– Power Distribution Unit

Group Setting

Parameter	Description	Values	Type
OpCode	A code to specify the command	0x81 for command 0x82 for response	Uint8
Status	A field applicable to response only notifying the execution status of the command.	See Status Values table	Bit[6]
R/W	A flag to set the command as write or read or macro command.	0 - Read 1 – Write	Bit[2]
Element	Selection of Channel	Channel 0-99 : 0 – 99	Uint8
Group	Number of group for selected Channel	Group 0-49 : 100 – 149 Ungroup : 251	Uint8

R/W	CalType	Data
Write	Offset calibration	If channel if off than an offset calibration is performed for current and voltage management. Data will be ignored If channel is off than the message will return Error 0x3F(General)
Write	Current Slope	Data[3:0] – the current measured externally formatted as value = Current*100 + 8,000,000

M9516 SERIES– Power Distribution Unit

Macro Record

Parameter	Description	Values	Type
OpCode	A code to specify the command	0x83 for command 0x84 for response	Uint8
Status	A field applicable to response only notifying the execution status of the command.	See Status Values table	Bit[6]
R/W	A flag to set the command as write or read or macro command.	1 – Write	Bit[2]
Element	Selection of element to configure macro to	POR – 230 DCI - 194	Uint8
State	Macro Start and stop options	0 – Stop Recording 1 – Start Recording high triggered macro 2 – Start Recording low triggered macro 3 – Change macro mask	Uint8

Delay (For Macro Use)

Parameter	Description	Values	Type
OpCode	A code to specify the command	0x85 for command 0x86 for response	Uint8
Status	A field applicable to response only notifying the execution status of the command.	See Status Values table	Bit[6]
R/W	A flag to set the command as write or read or macro command.	1 – Write	Bit[2]
Delay	Delay time in milliseconds		Uint16

M9516 SERIES— Power Distribution Unit

Dimensions:

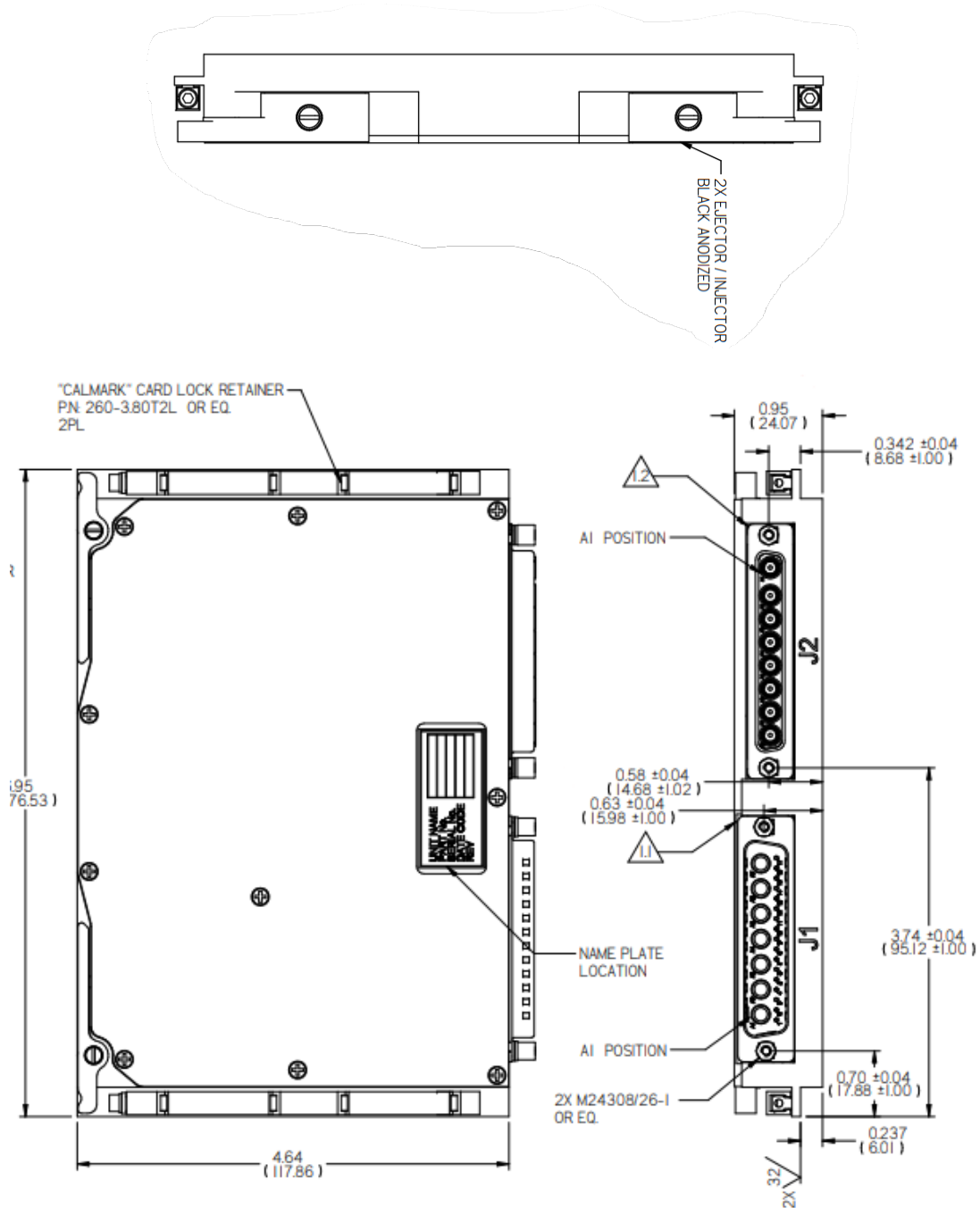

M9516 SERIES– Power Distribution Unit

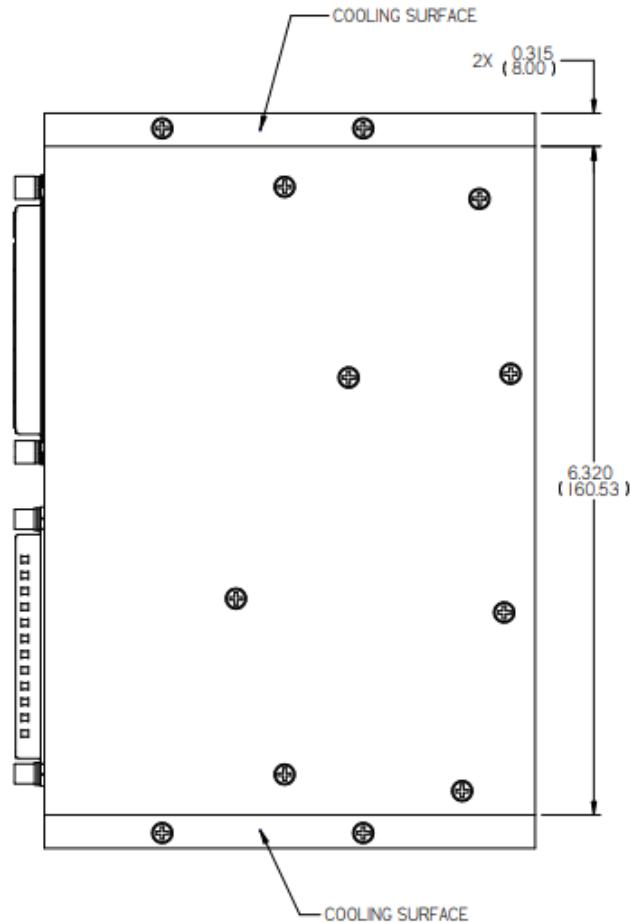

NOTES :

1. CONNECTORS:
 - 1.1 INPUT: CONEC 3024W7PCU60N20X OR EQ
 - 1.2 OUTPUT: CONEC 3008W8SXX58N20X OR EQ
2. HEAT DISSIPATION AREA - TOTAL AREA: 2.79[in²]
3. WORKMANSHIP SHALL BE MIL-STD-454, REQ. 9
4. MAIN BODY AND COVERS:
 - MATERIAL: ALUMINUM ALLOY (6061-T651 & 5052-H32)
 - FINISH: CHEMICAL CONVERSION COATING MIL-DTL-5541,TYPE 1 ,CLASS IA
5. EJECTOR / INJECTOR:
 - MATERIAL: ALUMINUM ALLOY (6061-T651)
 - FINISH: BLACK ANODIZE PER MIL-A-8625,TYPE 2 ,CLASS 2
6. WEIGHT: 1 [kg] MAX.
7. ENGRAVING
 - CHARACTER ARE CENTRALLY LOCATED,
 - CHARACTER HEIGHT : .20 IN
 - FILL ENGRAVING WITH BLACK LUSTERLESS
 - EPOXY PAINT COLOR PER FED-STD 595 NO : 37038.